

# Technical Support Center: Overcoming Intrinsic Resistance to Gunagratinib

**Author:** BenchChem Technical Support Team. **Date:** December 2025

## Compound of Interest

Compound Name: Anticancer agent 192

Cat. No.: B12372909

[Get Quote](#)

This technical support center provides researchers, scientists, and drug development professionals with troubleshooting guides and frequently asked questions (FAQs) to address intrinsic resistance to Gunagratinib, a potent and irreversible pan-FGFR inhibitor.

## Frequently Asked Questions (FAQs)

Q1: What is Gunagratinib and its mechanism of action?

Gunagratinib (ICP-192) is an orally active, small-molecule pan-inhibitor of fibroblast growth factor receptors (FGFRs 1, 2, 3, and 4)[1][2][3]. It selectively and irreversibly binds to the FGFR kinase domain, inhibiting its activity[2][4]. This leads to the suppression of tumor angiogenesis, tumor cell proliferation, and the induction of cell death in tumors with aberrant FGFR signaling. Preclinical data have indicated its potential to overcome acquired resistance to first-generation reversible FGFR inhibitors.

Q2: What is intrinsic (or primary) resistance to Gunagratinib?

Intrinsic resistance refers to the lack of a significant anti-tumor response upon initial treatment with Gunagratinib. This occurs in tumors that, despite harboring activating FGFR alterations, possess pre-existing mechanisms that circumvent the drug's inhibitory effects.

Q3: What are the primary known and suspected mechanisms of intrinsic resistance to FGFR inhibitors like Gunagratinib?

While research on Gunagratinib is ongoing, intrinsic resistance mechanisms are generally categorized into two main types based on extensive studies of other FGFR inhibitors:

- **On-target Alterations:** Although less common for intrinsic resistance compared to acquired resistance, pre-existing mutations in the FGFR gene at residues other than the primary activating mutation could potentially affect Gunagratinib binding or kinase activity.
- **Off-target Mechanisms (Bypass Signaling):** This is the most common cause of intrinsic resistance. The tumor cells rely on alternative signaling pathways for their growth and survival, rendering the inhibition of the FGFR pathway alone insufficient. Key bypass pathways include:
  - **Co-activation of other Receptor Tyrosine Kinases (RTKs):** Upregulation or activation of other RTKs like EGFR, MET, or ERBB family members can maintain downstream signaling despite FGFR inhibition. For instance, some cancer cells with activating FGFR3 mutations may exhibit a dependency on EGFR signaling.
  - **Downstream Pathway Alterations:** Pre-existing mutations in genes downstream of FGFR, such as in the RAS/MAPK or PI3K/AKT/mTOR pathways (e.g., KRAS, NRAS, PIK3CA mutations), can lead to constitutive activation of these pathways, making the cells independent of FGFR signaling.
  - **Epithelial-to-Mesenchymal Transition (EMT):** An EMT phenotype can be associated with intrinsic resistance to FGFR inhibitors.

## Troubleshooting Guide for Unexpected Experimental Results

This guide is designed to help researchers investigate potential intrinsic resistance to Gunagratinib in their experimental models.

### **Problem 1: Cell line with known FGFR alteration shows no response to Gunagratinib in vitro.**

Possible Cause 1: Suboptimal Drug Concentration or Experimental Conditions

- Troubleshooting Steps:
  - Confirm Drug Activity: Test Gunagratinib on a known sensitive control cell line to verify the potency of your drug stock.
  - Dose-Response Curve: Perform a dose-response experiment with a wide range of Gunagratinib concentrations to determine the IC50 value. An unexpectedly high IC50 may indicate resistance.
  - Treatment Duration: Ensure the treatment duration is sufficient (e.g., 72-96 hours) to observe an anti-proliferative effect.

#### Possible Cause 2: Presence of Bypass Signaling Pathways

- Troubleshooting Steps:
  - Pathway Activation Analysis:
    - Western Blot: Assess the phosphorylation status of key downstream signaling molecules (e.g., p-AKT, p-ERK, p-S6) with and without Gunagratinib treatment. Persistent phosphorylation despite FGFR inhibition suggests bypass pathway activation. A detailed protocol is provided below.
    - Phospho-RTK Array: Screen for the activation of multiple RTKs simultaneously to identify potential bypass signaling originating from receptors like EGFR, MET, or others.
  - Genomic and Transcriptomic Analysis:
    - Sequencing: Perform targeted sequencing or whole-exome sequencing to identify pre-existing mutations in key oncogenes of bypass pathways (e.g., PIK3CA, KRAS, NRAS, BRAF).
    - RNA-Seq: Analyze the gene expression profile to identify upregulation of RTKs or ligands that could be driving resistance.

#### Possible Cause 3: On-Target Resistance

- Troubleshooting Steps:

- FGFR Sequencing: Sequence the entire coding region of the relevant FGFR gene in your model to check for any secondary mutations that might interfere with Gunagratinib's irreversible binding, although this is more common in acquired resistance.

## Problem 2: In vivo tumor model with FGFR alteration does not respond to Gunagratinib.

### Possible Cause 1: Pharmacokinetic/Pharmacodynamic (PK/PD) Issues

- Troubleshooting Steps:
  - Verify Target Engagement: If possible, collect tumor samples post-treatment and perform a Western blot to assess the inhibition of p-FGFR and downstream markers like p-ERK. The presence of hyperphosphatemia in treated animals can also serve as a pharmacodynamic biomarker of FGFR inhibition.
  - Dosing and Formulation: Review the dosing regimen and vehicle to ensure adequate drug exposure.

### Possible Cause 2: Intrinsic Resistance Mechanisms

- Troubleshooting Steps:
  - Biopsy Analysis: Collect pre-treatment and on-treatment tumor biopsies for genomic and proteomic analysis as described for in vitro models to investigate bypass pathways.
  - Combination Therapy Studies: Based on the identified resistance mechanism, design a combination therapy study. For example, if PI3K/AKT pathway activation is observed, combine Gunagratinib with a PI3K or mTOR inhibitor.

## Strategies to Overcome Intrinsic Resistance

Based on preclinical and clinical studies of FGFR inhibitors, combination therapy is a promising strategy to overcome intrinsic resistance.

Table 1: Potential Combination Strategies to Overcome Intrinsic Resistance

Identified Resistance Mechanism	Recommended Combination Agent Class	Rationale
PI3K/AKT/mTOR Pathway Activation	PI3K, AKT, or mTOR inhibitors (e.g., Everolimus)	Dual inhibition blocks parallel survival pathways, leading to synergistic anti-tumor effects.
RAS/MAPK Pathway Activation	MEK inhibitors (e.g., Trametinib)	Co-inhibition of FGFR and MEK can prevent reactivation of the ERK pathway.
EGFR/ERBB Pathway Upregulation	EGFR inhibitors (e.g., Gefitinib, Cetuximab)	Simultaneous blockade of both FGFR and EGFR signaling can overcome adaptive feedback and enhance apoptosis.
MET Pathway Activation	MET inhibitors (e.g., Crizotinib)	Co-targeting FGFR and MET may provide synergistic benefits in tumors where MET is a bypass driver.

## Key Experimental Protocols

### Protocol 1: Western Blot Analysis for Pathway Activation

- **Cell Seeding and Treatment:** Seed cells in 6-well plates and allow them to adhere overnight. Treat with Gunagratinib at various concentrations (e.g., 0, 10 nM, 100 nM, 1  $\mu$ M) for 2-24 hours.
- **Cell Lysis:** Wash cells with ice-cold PBS and lyse with RIPA buffer supplemented with protease and phosphatase inhibitors.
- **Protein Quantification:** Determine protein concentration using a BCA assay.
- **SDS-PAGE and Transfer:** Load equal amounts of protein onto an SDS-PAGE gel, run the gel, and transfer the proteins to a PVDF membrane.

- **Antibody Incubation:** Block the membrane with 5% BSA or non-fat milk for 1 hour. Incubate with primary antibodies overnight at 4°C. Recommended antibodies: p-FGFR, total FGFR, p-AKT (Ser473), total AKT, p-ERK1/2 (Thr202/Tyr204), total ERK1/2, and a loading control (e.g., GAPDH,  $\beta$ -actin).
- **Detection:** Wash the membrane and incubate with HRP-conjugated secondary antibodies for 1 hour at room temperature. Detect the signal using an enhanced chemiluminescence (ECL) substrate.

## Protocol 2: In Vitro Combination Therapy Assay

- **Cell Seeding:** Seed cells in 96-well plates.
- **Drug Treatment:** Treat cells with a matrix of concentrations of Gunagratinib and the combination agent (e.g., a PI3K or MEK inhibitor). Include single-agent controls for each drug.
- **Cell Viability Assay:** After 72-96 hours of incubation, measure cell viability using an assay such as CellTiter-Glo® or MTS.
- **Synergy Analysis:** Calculate the Combination Index (CI) using software like CompuSyn. A CI < 1 indicates synergy, CI = 1 indicates an additive effect, and CI > 1 indicates antagonism.

## Visualizing Resistance Mechanisms and Experimental Workflows

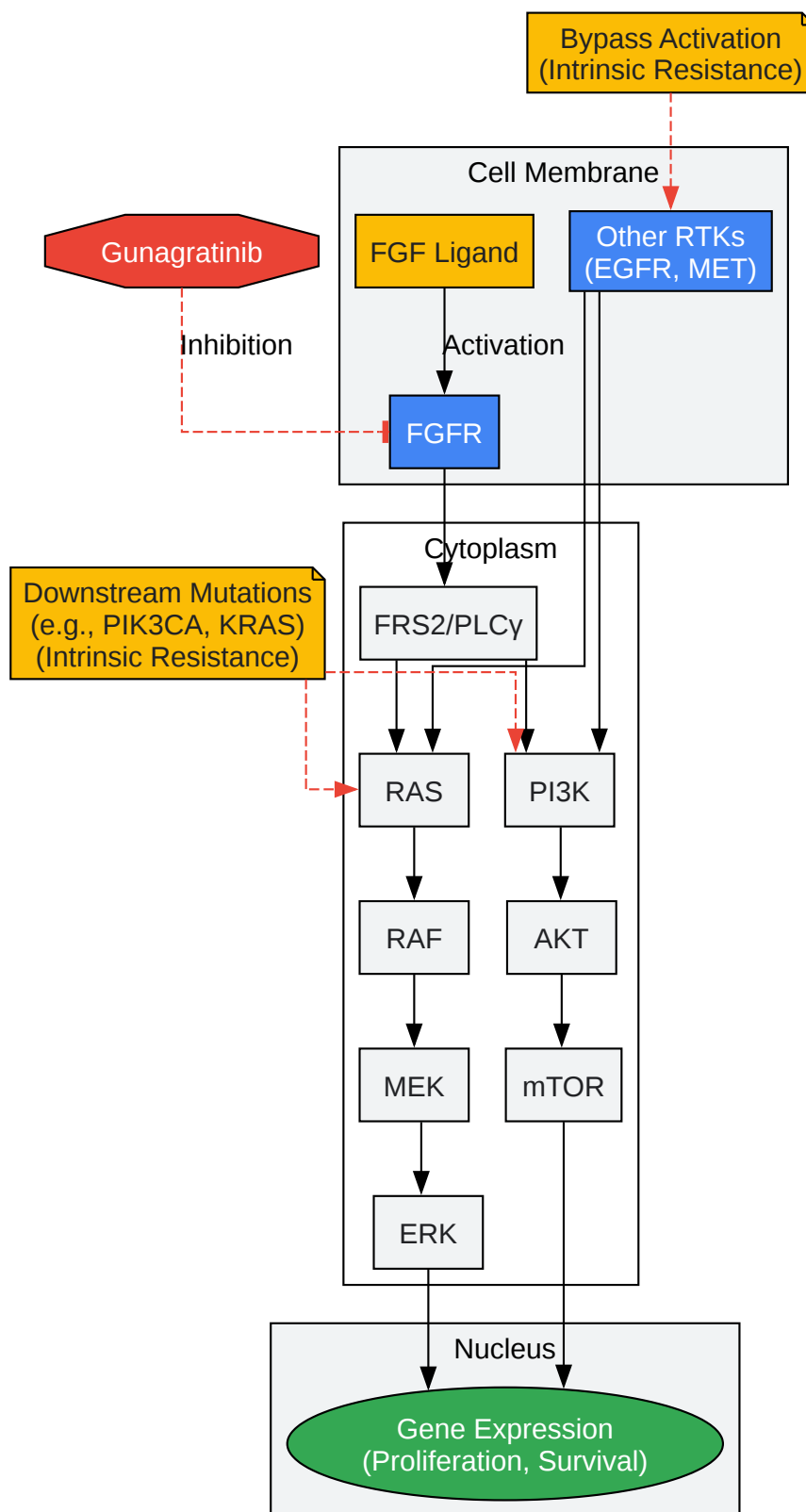

[Click to download full resolution via product page](#)

Caption: Intrinsic resistance to Gunagratinib via bypass signaling pathways.

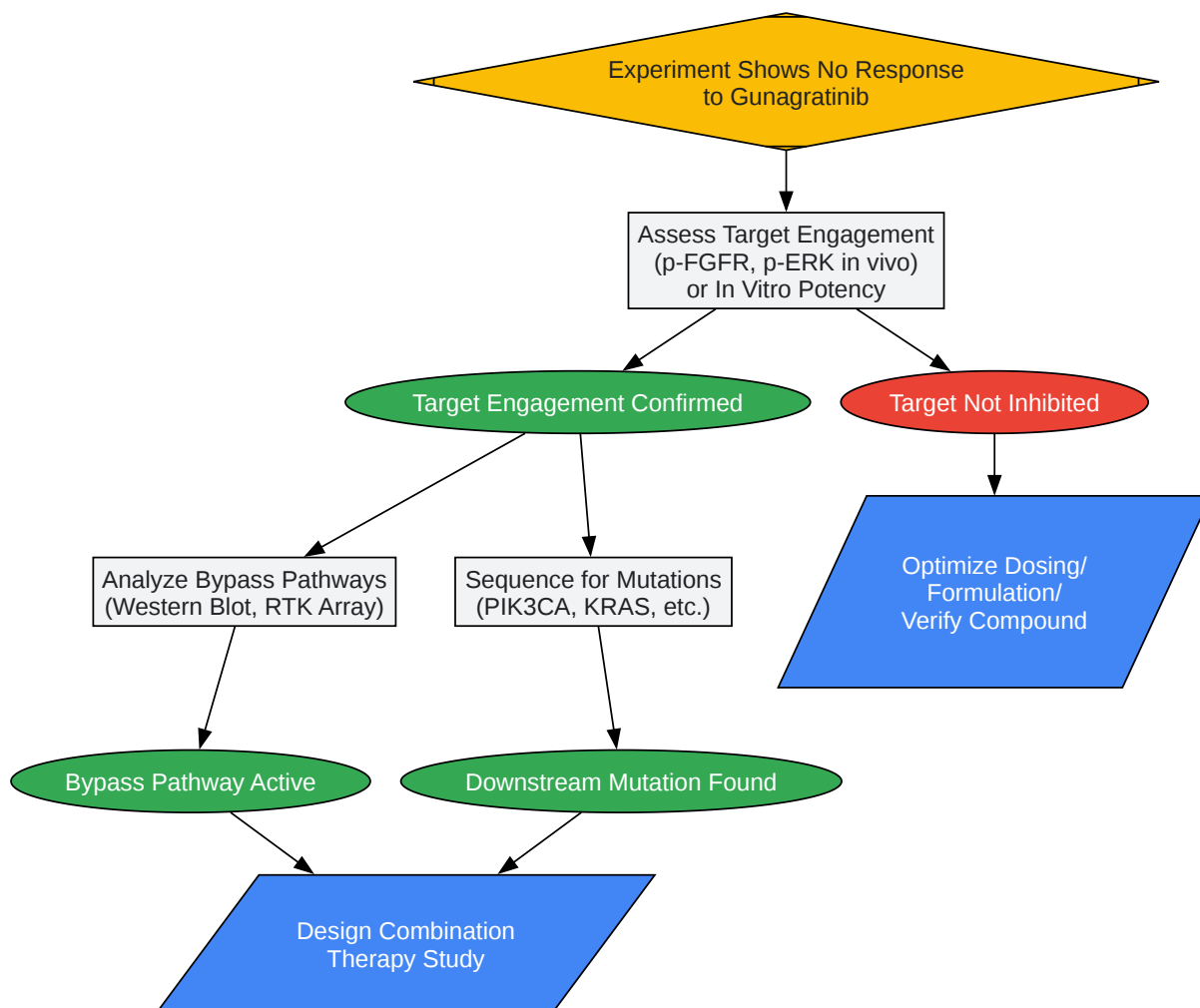

[Click to download full resolution via product page](#)



**Need Custom Synthesis?**

BenchChem offers custom synthesis for rare earth carbides and specific isotopic labeling.

Email: [info@benchchem.com](mailto:info@benchchem.com) or [Request Quote Online](#).

## References

- 1. [mdpi.com](https://www.mdpi.com) [[mdpi.com](https://www.mdpi.com)]
- 2. [ascopubs.org](https://ascopubs.org) [[ascopubs.org](https://ascopubs.org)]
- 3. Gunagratinib, a highly selective irreversible FGFR inhibitor, in patients with previously treated locally advanced or metastatic cholangiocarcinoma harboring FGFR pathway alterations: A phase IIa dose-expansion study. - ASCO [[asco.org](https://ascopubs.org)]
- 4. InnoCare Presents Latest Clinical Data of pan-FGFR Inhibitor Gunagratinib at the 2021 ASCO Annual Meeting [[businesswire.com](https://www.businesswire.com)]
- To cite this document: BenchChem. [Technical Support Center: Overcoming Intrinsic Resistance to Gunagratinib]. BenchChem, [2025]. [Online PDF]. Available at: [<https://www.benchchem.com/product/b12372909#overcoming-intrinsic-resistance-to-gunagratinib>]

---

**Disclaimer & Data Validity:**

The information provided in this document is for Research Use Only (RUO) and is strictly not intended for diagnostic or therapeutic procedures. While BenchChem strives to provide accurate protocols, we make no warranties, express or implied, regarding the fitness of this product for every specific experimental setup.

**Technical Support:** The protocols provided are for reference purposes. Unsure if this reagent suits your experiment? [[Contact our Ph.D. Support Team for a compatibility check](#)]

**Need Industrial/Bulk Grade?** [Request Custom Synthesis Quote](#)

# BenchChem

Our mission is to be the trusted global source of essential and advanced chemicals, empowering scientists and researchers to drive progress in science and industry.

## Contact

Address: 3281 E Guasti Rd

Ontario, CA 91761, United States

Phone: (601) 213-4426

Email: [info@benchchem.com](mailto:info@benchchem.com)