

Technical Support Center: Optimizing ONC212 and Crizotinib Synergistic Dosing

Author: BenchChem Technical Support Team. **Date:** December 2025

Compound of Interest

Compound Name: Anticancer agent 212

Cat. No.: B15561176

[Get Quote](#)

This technical support center provides researchers, scientists, and drug development professionals with troubleshooting guides and frequently asked questions (FAQs) for optimizing the synergistic dosing of ONC212 and crizotinib.

Frequently Asked Questions (FAQs)

Q1: What is the rationale for combining ONC212 and crizotinib?

A1: The combination of ONC212 and crizotinib is based on their distinct and potentially complementary anti-cancer mechanisms. Crizotinib is a potent tyrosine kinase inhibitor (TKI) that targets ALK, ROS1, and c-MET, which are key drivers in certain cancers.[1][2][3] ONC212, on the other hand, is an imipridone that acts as an agonist of the G protein-coupled receptor GPR132 and induces the integrated stress response (ISR).[4] This leads to the upregulation of the TRAIL/DR5 pathway and mitochondrial dysfunction, ultimately inducing apoptosis. By targeting different signaling pathways, the combination has the potential to overcome resistance mechanisms and achieve a more potent anti-tumor effect than either agent alone.

Q2: In which cancer types or cell lines has synergy between ONC212 and crizotinib been observed?

A2: Preclinical studies have shown synergistic activity between ONC212 and crizotinib in specific cancer cell lines. Notably, synergy has been reported in the PANC-1 human pancreatic cancer cell line, which is known to overexpress Anaplastic Lymphoma Kinase (ALK).[4][5] However, this synergistic effect was not observed in the BxPC-3 pancreatic cancer cell line,

which has high expression of c-MET.[4][5] This suggests that the synergistic interaction may be context-dependent and potentially influenced by the specific receptor tyrosine kinase expression profile of the cancer cells.

Q3: What is the proposed mechanism for the synergistic interaction between ONC212 and crizotinib in ALK-positive cells?

A3: While the precise mechanism is still under investigation, the synergy in ALK-overexpressing cells like PANC-1 is thought to arise from the dual targeting of critical survival pathways. Crizotinib directly inhibits the pro-proliferative and anti-apoptotic signaling downstream of ALK.[6] Concurrently, ONC212 induces a cellular stress response and activates the extrinsic and intrinsic apoptosis pathways.[7][8] The combined effect of inhibiting a key oncogenic driver (ALK) while simultaneously inducing cellular stress and apoptosis through a separate mechanism likely lowers the threshold for cell death, leading to a synergistic outcome.

Q4: Why might synergy not be observed in c-MET-driven cells like BxPC-3?

A4: The lack of synergy in c-MET expressing BxPC-3 cells suggests that the interplay between the c-MET signaling pathway and the pathways targeted by ONC212 may be different from that of the ALK pathway. It is possible that c-MET signaling activates downstream effectors that can compensate for the stress induced by ONC212, or that the c-MET-driven cellular context is less reliant on the pathways that ONC212 modulates for survival.[9][10] Further research is needed to elucidate the specific molecular interactions that govern this differential response.

Troubleshooting Guides

Problem 1: Inconsistent or No Synergy Observed in ALK-Positive Cell Lines

Possible Cause	Troubleshooting Steps
Suboptimal Drug Concentrations	<ul style="list-style-type: none"> - Perform single-agent dose-response curves for both ONC212 and crizotinib to determine the IC50 for each drug in your specific cell line. - Design synergy experiments using a range of concentrations around the IC50 values for both drugs. A common starting point is a matrix of concentrations from 0.1x to 10x the IC50.
Incorrect Drug Ratio	<ul style="list-style-type: none"> - The optimal ratio for synergy can be drug- and cell line-dependent. - Test different fixed ratios of ONC212 to crizotinib (e.g., 1:1, 1:5, 5:1 based on their IC50 values) to identify the most synergistic combination.
Cell Line Integrity and Passage Number	<ul style="list-style-type: none"> - Ensure that the PANC-1 cell line has not undergone significant genetic drift. Use low-passage number cells for experiments. - Periodically verify the expression of ALK in your PANC-1 cell line via Western blot or qPCR.
Experimental Assay Variability	<ul style="list-style-type: none"> - Ensure consistent cell seeding density and incubation times. - Use a reliable cell viability assay such as CellTiter-Glo®. - Include appropriate vehicle controls for both drugs.
Data Analysis Method	<ul style="list-style-type: none"> - Utilize established methods for synergy analysis, such as the Combination Index (CI) method by Chou-Talalay.^{[2][5]} A CI value < 1 indicates synergy. - Software such as CompuSyn can be used for automated calculation of CI values.

Problem 2: High Background Toxicity or Unexpected Cell Death in Controls

Possible Cause	Troubleshooting Steps
Solvent Toxicity	- Both ONC212 and crizotinib are typically dissolved in DMSO. Ensure the final concentration of DMSO in the culture medium is low (ideally <0.1%) and consistent across all wells, including vehicle controls.
Cell Culture Conditions	- Optimize cell seeding density to avoid overgrowth or nutrient depletion during the course of the experiment (typically 72 hours). - Ensure proper sterile technique to prevent contamination.
Drug Stability	- Prepare fresh drug dilutions for each experiment from frozen stocks. - Store stock solutions at the recommended temperature (-20°C or -80°C) and protect from light.

Data Presentation

The following tables provide a template for summarizing quantitative data from ONC212 and crizotinib combination experiments.

Table 1: Single-Agent IC50 Values

Cell Line	Drug	IC50 (µM) after 72h
PANC-1	ONC212	[Insert experimental value]
Crizotinib	[Insert experimental value]	
BxPC-3	ONC212	[Insert experimental value]
Crizotinib	[Insert experimental value]	

Table 2: Combination Index (CI) Values for ONC212 and Crizotinib in PANC-1 Cells

ONC212 (μM)	Crizotinib (μM)	Fraction Affected (Fa)	Combination Index (CI)	Synergy Interpretation
[Dose 1]	[Dose A]	[Value]	[Value]	[Synergistic/Additive/Antagonistic]
[Dose 2]	[Dose B]	[Value]	[Value]	[Synergistic/Additive/Antagonistic]
[Dose 3]	[Dose C]	[Value]	[Value]	[Synergistic/Additive/Antagonistic]

“

Note: $CI < 0.9$ indicates synergy, CI between 0.9 and 1.1 is additive, and $CI > 1.1$ indicates antagonism.

Experimental Protocols

Protocol 1: In Vitro Synergy Assessment using the Combination Index (CI) Method

1. Materials:

- PANC-1 and BxPC-3 human pancreatic cancer cell lines
- ONC212 (stock solution in DMSO)
- Crizotinib (stock solution in DMSO)
- Cell culture medium (e.g., DMEM with 10% FBS)
- 96-well cell culture plates
- CellTiter-Glo® Luminescent Cell Viability Assay
- Plate reader capable of measuring luminescence

2. Procedure:

3. Data Analysis:

- Calculate the Fraction affected (Fa) for each treatment, where $Fa = 1 - (\text{viability of treated cells} / \text{viability of control cells})$.
- Use software like CompuSyn to input the dose-effect data for single agents and combinations to calculate the Combination Index (CI).
- A CI value less than 1 indicates synergy, a CI value equal to 1 indicates an additive effect, and a CI value greater than 1 indicates antagonism.

Mandatory Visualizations

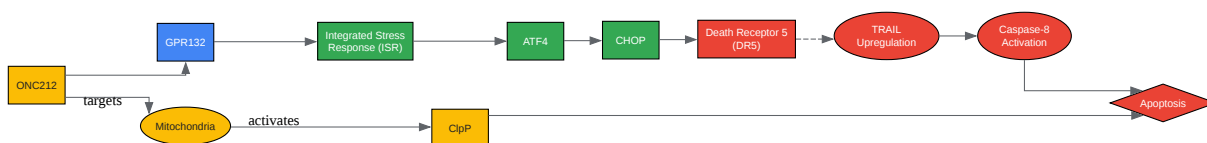

[Click to download full resolution via product page](#)

ONC212 Signaling Pathway

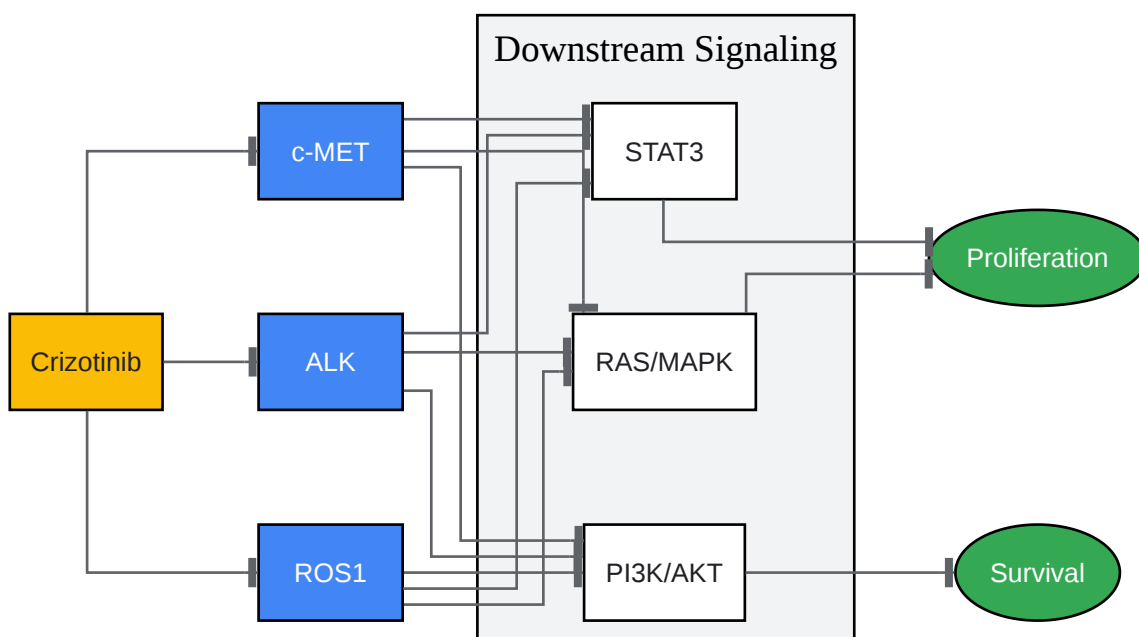

[Click to download full resolution via product page](#)

Crizotinib Signaling Pathway

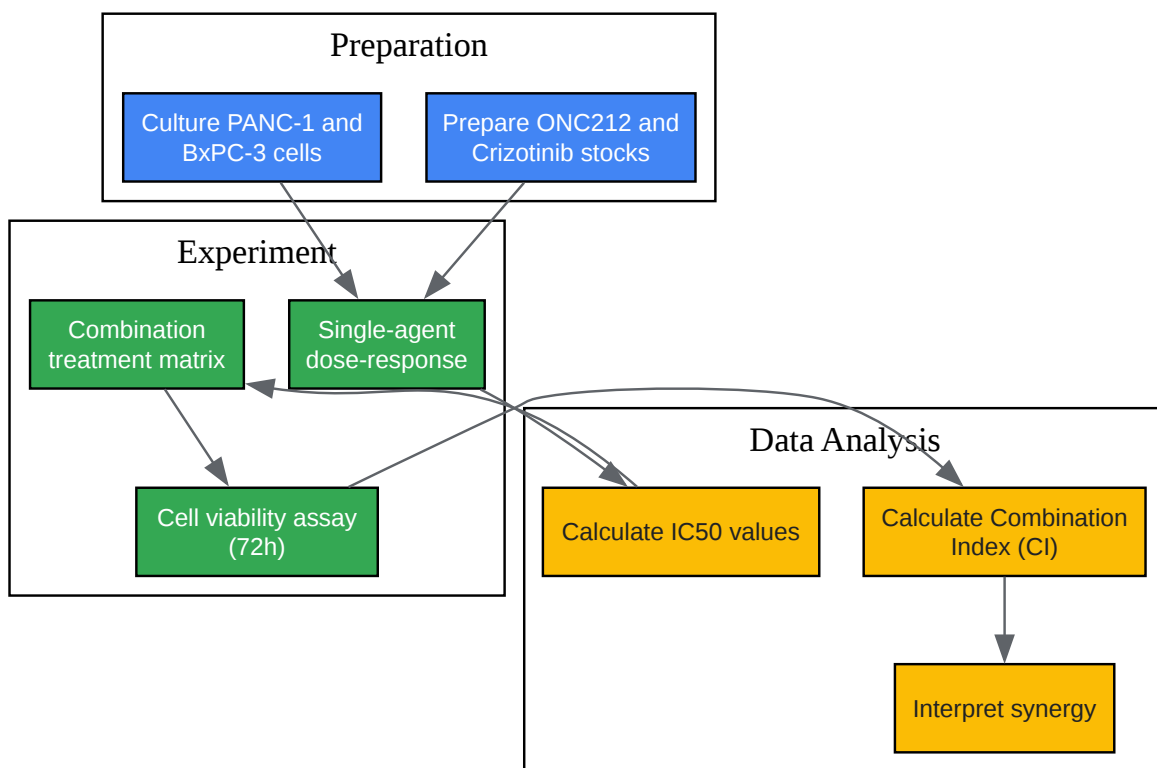

[Click to download full resolution via product page](#)

Experimental Workflow for Synergy

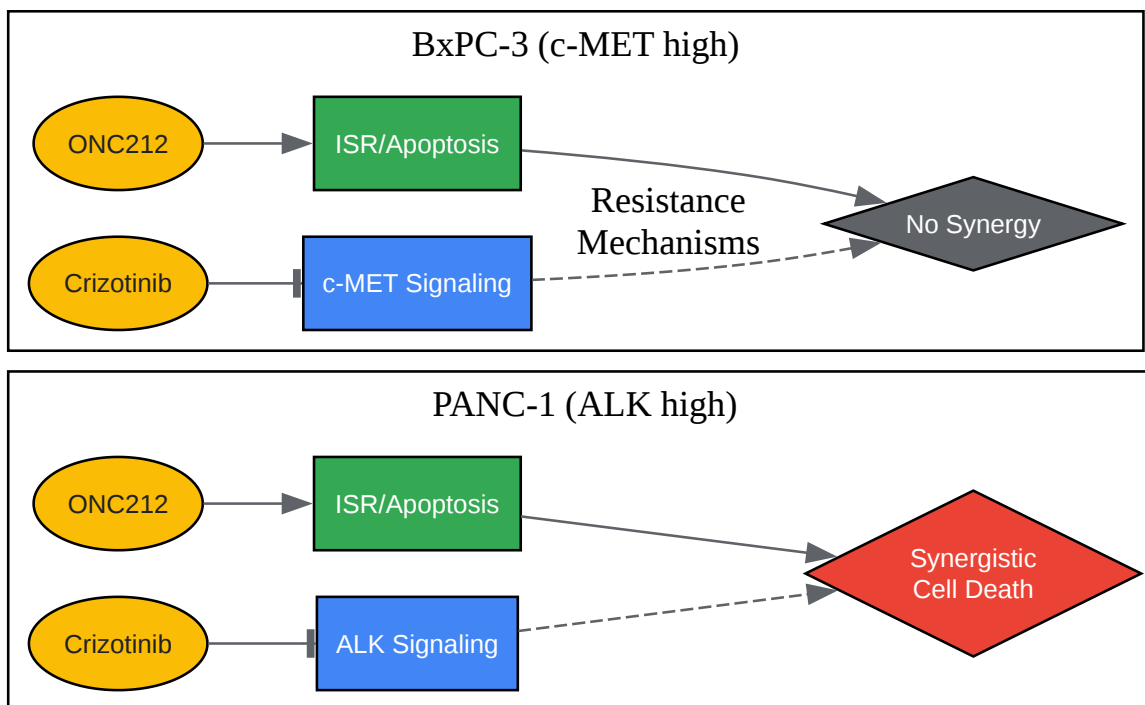

[Click to download full resolution via product page](#)

Logical Relationship of Synergy

Need Custom Synthesis?

BenchChem offers custom synthesis for rare earth carbides and specific isotopic labeling.

Email: info@benchchem.com or [Request Quote Online](#).

References

- 1. Anti-pancreatic cancer activity of ONC212 involves the unfolded protein response (UPR) and is reduced by IGF1-R and GRP78/BIP - PMC [pmc.ncbi.nlm.nih.gov]
- 2. punnettsquare.org [punnettsquare.org]
- 3. Synergistic combination of microtubule targeting anticancer fludelone with cytoprotective panaxytriol derived from panax ginseng against MX-1 cells in vitro: experimental design and data analysis using the combination index method - PMC [pmc.ncbi.nlm.nih.gov]
- 4. Evaluation of synergism in drug combinations and reference models for future orientations in oncology - PMC [pmc.ncbi.nlm.nih.gov]

- 5. researchgate.net [researchgate.net]
- 6. researchgate.net [researchgate.net]
- 7. ONC212 is a Novel Mitocan Acting Synergistically with Glycolysis Inhibition in Pancreatic Cancer - PubMed [pubmed.ncbi.nlm.nih.gov]
- 8. Challenges to determine synergistic drug interactions in mice - PMC [pmc.ncbi.nlm.nih.gov]
- 9. Significance of c-MET overexpression in cytotoxic anticancer drug-resistant small-cell lung cancer cells - PMC [pmc.ncbi.nlm.nih.gov]
- 10. c-Met signaling in the development of tumorigenesis and chemoresistance: Potential applications in pancreatic cancer - PMC [pmc.ncbi.nlm.nih.gov]
- To cite this document: BenchChem. [Technical Support Center: Optimizing ONC212 and Crizotinib Synergistic Dosing]. BenchChem, [2025]. [Online PDF]. Available at: [https://www.benchchem.com/product/b15561176#optimizing-onc212-and-crizotinib-synergistic-dosing]

Disclaimer & Data Validity:

The information provided in this document is for Research Use Only (RUO) and is strictly not intended for diagnostic or therapeutic procedures. While BenchChem strives to provide accurate protocols, we make no warranties, express or implied, regarding the fitness of this product for every specific experimental setup.

Technical Support: The protocols provided are for reference purposes. Unsure if this reagent suits your experiment? [[Contact our Ph.D. Support Team for a compatibility check](#)]

Need Industrial/Bulk Grade? [Request Custom Synthesis Quote](#)

BenchChem

Our mission is to be the trusted global source of essential and advanced chemicals, empowering scientists and researchers to drive progress in science and industry.

Contact

Address: 3281 E Guasti Rd

Ontario, CA 91761, United States

Phone: (601) 213-4426

Email: info@benchchem.com