

Technical Support Center: Optimizing Magnesium Concentration for Olivomycin D-DNA Binding

Author: BenchChem Technical Support Team. **Date:** December 2025

Compound of Interest

Compound Name: *Olivomycin D*

Cat. No.: *B3344421*

[Get Quote](#)

Disclaimer: The following guide is based on extensive research on Olivomycin A and other aureolic acid antibiotics. While **Olivomycin D** is a closely related isomer, specific quantitative data and optimized protocols may vary. The principles and troubleshooting strategies outlined here provide a strong foundation for your experiments with **Olivomycin D**.

Frequently Asked Questions (FAQs)

Q1: What is the role of magnesium in the binding of **Olivomycin D** to DNA?

Magnesium ions (Mg^{2+}) are crucial for the interaction between **Olivomycin D** and DNA. **Olivomycin D**, like other aureolic acid antibiotics, binds to the minor groove of GC-rich regions of double-stranded DNA. This binding is mediated by the formation of a dimer of two **Olivomycin D** molecules chelated by a single divalent metal ion, typically Mg^{2+} . This 2:1 (**Olivomycin D**: Mg^{2+}) complex is the active form that binds to DNA.[1][2] The magnesium ion coordinates with the C-9 hydroxyl group and the adjacent C-1 aglycone carbonyl group of each Olivomycin molecule, stabilizing the dimer and facilitating its insertion into the DNA minor groove.

Q2: What is the typical stoichiometry of the **Olivomycin D**-DNA complex?

The binding of the **Olivomycin D**- Mg^{2+} complex to DNA generally follows a 2:1 stoichiometry, meaning two molecules of **Olivomycin D** (as a dimer) bind to one DNA binding site.[3] The

minimal binding site is typically a GC-rich sequence of four base pairs.

Q3: What happens if I don't add magnesium to my binding reaction?

In the absence of divalent cations like Mg^{2+} , the formation of the **Olivomycin D** dimer is significantly impaired. Consequently, its binding affinity for DNA is drastically reduced.[2] Fluorescence titration experiments with the closely related Olivomycin A have shown that without Mg^{2+} , there is very little change in fluorescence upon addition of DNA, indicating a lack of significant interaction.[2]

Q4: Can other divalent cations be used instead of magnesium?

Yes, other divalent cations such as Ni^{2+} , Co^{2+} , or Fe^{2+} can also mediate the formation of the Olivomycin-DNA complex, and in some cases, may even show stronger effects than Mg^{2+} . [2] However, Mg^{2+} is the most commonly used and studied cation for this interaction.

Troubleshooting Guide

Issue 1: Low or no observed binding of **Olivomycin D** to DNA.

- Possible Cause 1: Suboptimal Magnesium Concentration.
 - Solution: The concentration of Mg^{2+} is critical. Too low a concentration will result in insufficient formation of the active **Olivomycin D**- Mg^{2+} dimer. Conversely, excessively high concentrations can lead to non-specific interactions and precipitation. It is recommended to perform a titration experiment to determine the optimal Mg^{2+} concentration for your specific DNA sequence and experimental conditions. Start with a concentration range of 1-10 mM $MgCl_2$. A common starting point is 5 mM $MgCl_2$. [3]
- Possible Cause 2: Presence of Chelating Agents.
 - Solution: Ensure that your buffers, particularly for techniques like Electrophoretic Mobility Shift Assay (EMSA), do not contain chelating agents like EDTA. EDTA will sequester the Mg^{2+} ions, preventing the formation of the **Olivomycin D**- Mg^{2+} complex. If EDTA is required for other experimental reasons, its concentration must be significantly lower than the Mg^{2+} concentration. For EMSA, consider using a TBM (Tris/Boric acid/Magnesium) buffer instead of a TBE (Tris/Boric acid/EDTA) buffer. [3]

- Possible Cause 3: Incorrect DNA Sequence.
 - Solution: **Olivomycin D** preferentially binds to GC-rich sequences. Confirm that your DNA probe or target sequence contains appropriate binding sites (e.g., GG, GC).[3][4]

Issue 2: Non-specific binding or smearing in Electrophoretic Mobility Shift Assays (EMSA).

- Possible Cause 1: High Magnesium Concentration.
 - Solution: As mentioned, an excess of Mg^{2+} can promote non-specific electrostatic interactions between the negatively charged DNA and the positively charged complex. Try reducing the $MgCl_2$ concentration in your binding buffer. The addition of 10 mM $MgCl_2$ has been shown to increase the sequence specificity of some DNA-binding proteins by inhibiting binding to non-consensus sequences.[5]
- Possible Cause 2: Inappropriate Salt Concentration.
 - Solution: The overall ionic strength of the buffer can influence binding. While Mg^{2+} is essential, the concentration of monovalent salts (e.g., NaCl, KCl) can also affect specificity. Optimize the salt concentration in your binding buffer, typically in the range of 50-150 mM.

Issue 3: Inconsistent results in fluorescence spectroscopy.

- Possible Cause 1: Inner Filter Effect.
 - Solution: At high concentrations of **Olivomycin D** or DNA, the excitation or emission light can be absorbed by the sample itself, leading to non-linear and inaccurate fluorescence readings. Ensure your concentrations are within a range that avoids this effect. This can be checked by measuring the absorbance of your sample at the excitation and emission wavelengths.
- Possible Cause 2: Photobleaching.
 - Solution: **Olivomycin D** is a fluorescent molecule and can be susceptible to photobleaching upon prolonged exposure to the excitation light. Minimize exposure time and use the lowest effective excitation intensity.

Quantitative Data Summary

The following table summarizes key quantitative parameters for the interaction of Olivomycin A (as a proxy for **Olivomycin D**) with DNA in the presence of Mg^{2+} .

Parameter	Value	Experimental Conditions	Reference
Stoichiometry (Olivomycin:DNA)	2:1	Fluorescence Titration, Circular Dichroism	[3]
Binding Affinity (Kd)	Varies with sequence and ionic strength	Fluorescence Titration	[2]
Optimal Mg^{2+} Concentration	Empirically determined, typically 3-5 mM	EMSA, Fluorescence Spectroscopy	[3][6]
Binding Site Preference	GC-rich sequences (GG, GC)	EMSA	[3][4]

Experimental Protocols

Fluorescence Spectroscopy Titration to Determine Optimal Mg^{2+} Concentration

This protocol outlines a method to determine the optimal Mg^{2+} concentration for **Olivomycin D**-DNA binding by monitoring the enhancement of **Olivomycin D** fluorescence.

- Reagent Preparation:
 - **Olivomycin D** Stock Solution: Prepare a concentrated stock solution in a suitable solvent (e.g., ethanol or DMSO) and determine its concentration spectrophotometrically.
 - DNA Stock Solution: Prepare a stock solution of your target DNA in a low-salt buffer (e.g., 10 mM Tris-HCl, pH 7.5). Determine the concentration using A_{260} measurements.
 - Binding Buffer: 10 mM Tris-HCl, 100 mM NaCl, pH 7.5.

- MgCl₂ Stock Solution: 1 M MgCl₂.
- Experimental Setup:
 - Set the excitation wavelength of the spectrofluorometer to the absorption maximum of the **Olivomycin D**-Mg²⁺ complex (around 440 nm) and the emission wavelength to its fluorescence maximum (around 520 nm). Slit widths should be optimized for signal-to-noise ratio.
- Titration Procedure:
 - In a cuvette, add the binding buffer and a fixed concentration of **Olivomycin D** (e.g., 1 μM).
 - Add a fixed, saturating concentration of your target DNA (e.g., 10 μM base pairs).
 - Incrementally add small aliquots of the MgCl₂ stock solution to achieve final concentrations ranging from 0 to 10 mM.
 - After each addition, mix gently and allow the reaction to equilibrate for 5-10 minutes before recording the fluorescence intensity.
 - Plot the fluorescence intensity as a function of MgCl₂ concentration. The optimal concentration will correspond to the plateau of the binding curve.

Electrophoretic Mobility Shift Assay (EMSA)

This protocol is for visualizing the formation of the **Olivomycin D**-DNA complex.

- Probe Preparation:
 - Synthesize and purify complementary oligonucleotides containing the target GC-rich sequence.
 - Label one oligonucleotide with a suitable tag (e.g., biotin or a fluorescent dye).
 - Anneal the labeled and unlabeled oligonucleotides to form a double-stranded DNA probe.

- Binding Reaction (20 μ L total volume):
 - 10 μ L of 2x Binding Buffer (40 mM Tris-HCl pH 8.0, 200 mM NaCl, 10 mM MgCl₂)
 - 1 μ L of labeled DNA probe (e.g., 10 nM final concentration)
 - 1 μ L of Poly(dI-dC) (non-specific competitor DNA, 1 μ g/ μ L)
 - X μ L of **Olivomycin D** (titrate concentrations, e.g., 0.1 to 5 μ M)
 - (9-X) μ L of nuclease-free water
- Procedure:
 - Combine all components except the labeled probe and incubate at room temperature for 10 minutes.
 - Add the labeled probe and incubate for an additional 30 minutes at room temperature, protected from light.
 - Add 2 μ L of 6x loading dye.
 - Load the samples onto a native polyacrylamide gel (e.g., 6-8%) in 0.5x TBM buffer (45 mM Tris-borate, 1 mM MgCl₂).
 - Run the gel at a constant voltage (e.g., 100-150V) at 4°C.
 - Visualize the bands using an appropriate imaging system. A shifted band indicates the formation of the **Olivomycin D**-DNA complex.

Circular Dichroism (CD) Spectroscopy

CD spectroscopy can be used to monitor conformational changes in DNA upon binding of the **Olivomycin D**-Mg²⁺ complex.

- Sample Preparation:
 - Prepare solutions of DNA (e.g., 20 μ M) in a low-salt buffer (e.g., 10 mM phosphate buffer, pH 7.2).

- Prepare a stock solution of **Olivomycin D**.
- Prepare a stock solution of MgCl_2 .
- Measurement:
 - Record the CD spectrum of the DNA alone from 220 to 320 nm.
 - Add MgCl_2 to the DNA solution to the desired final concentration (e.g., 5 mM) and record the spectrum again (this should show minimal change).
 - Titrate the DNA- Mg^{2+} solution with increasing concentrations of **Olivomycin D**.
 - Record the CD spectrum after each addition and equilibration.
- Analysis:
 - Binding of the **Olivomycin D**- Mg^{2+} complex to B-form DNA will induce characteristic changes in the CD spectrum, typically an increase in the positive band around 275 nm and the appearance of an induced CD band in the visible region (around 440 nm) where the drug absorbs. These changes can be used to calculate binding affinity and stoichiometry.

Visualizations

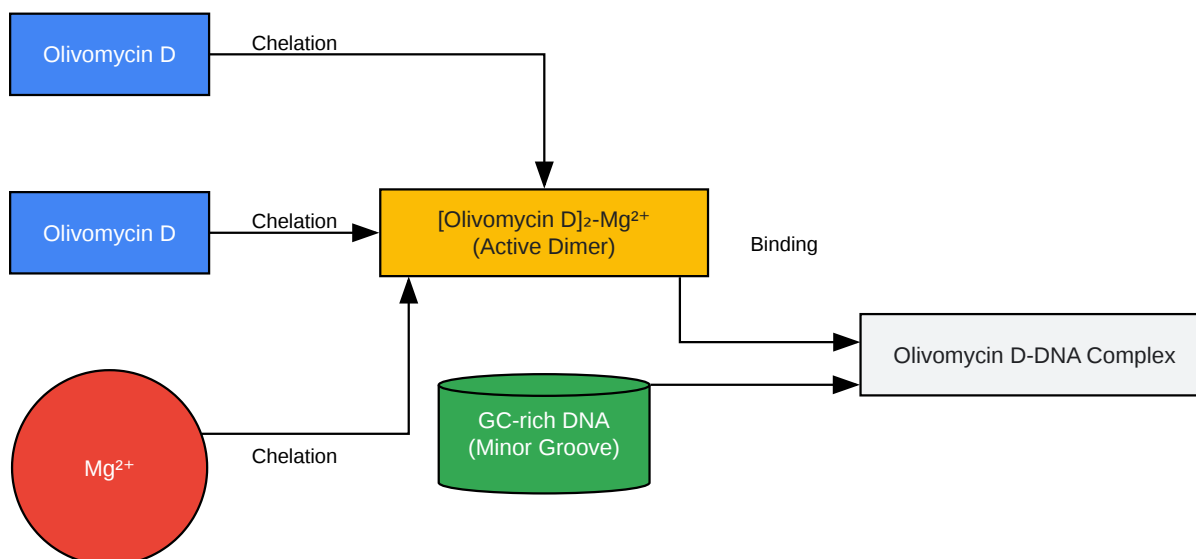

[Click to download full resolution via product page](#)

Caption: Mechanism of **Olivomycin D**-DNA complex formation.

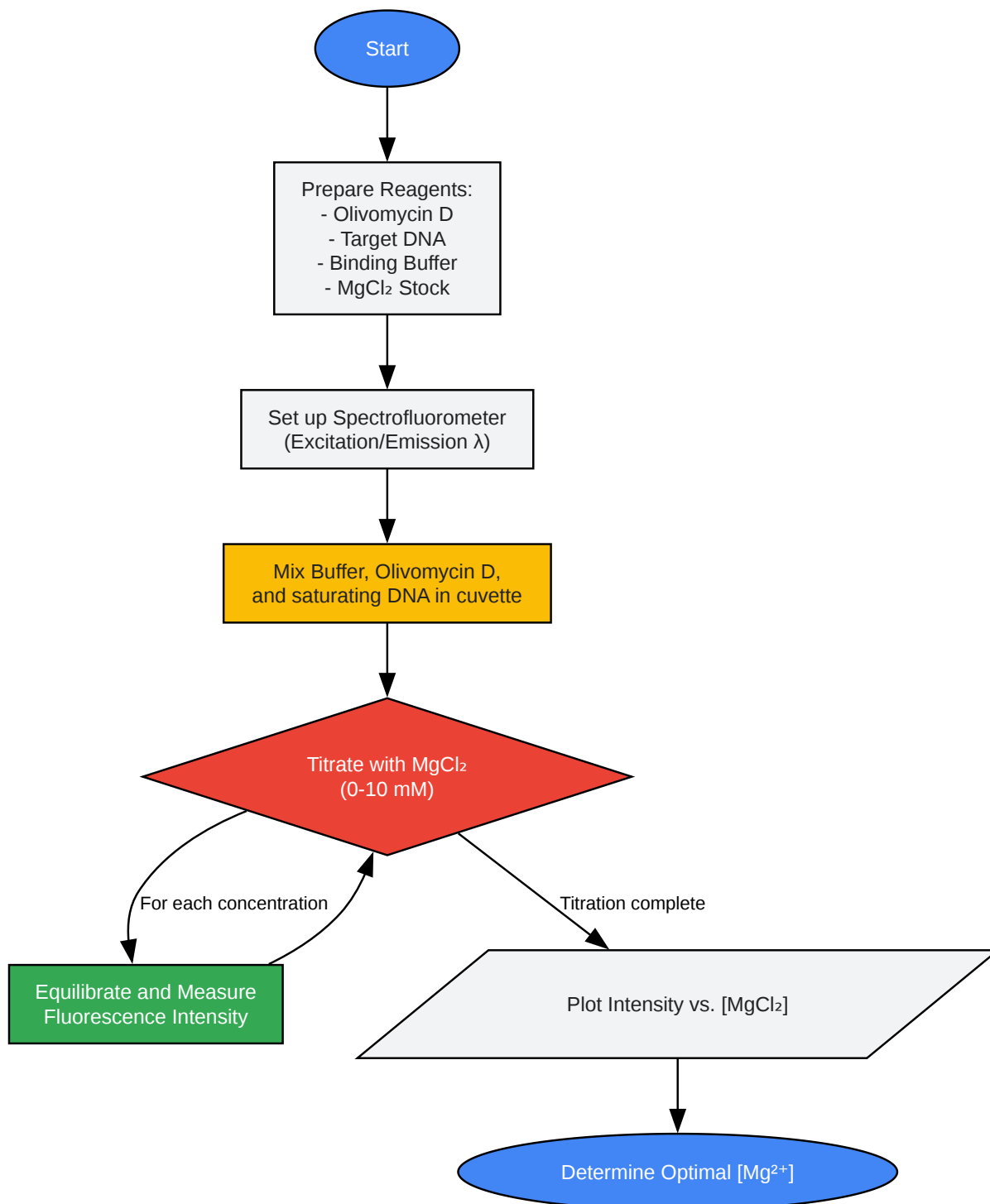

[Click to download full resolution via product page](#)

Caption: Workflow for fluorescence titration to find optimal $[Mg^{2+}]$.

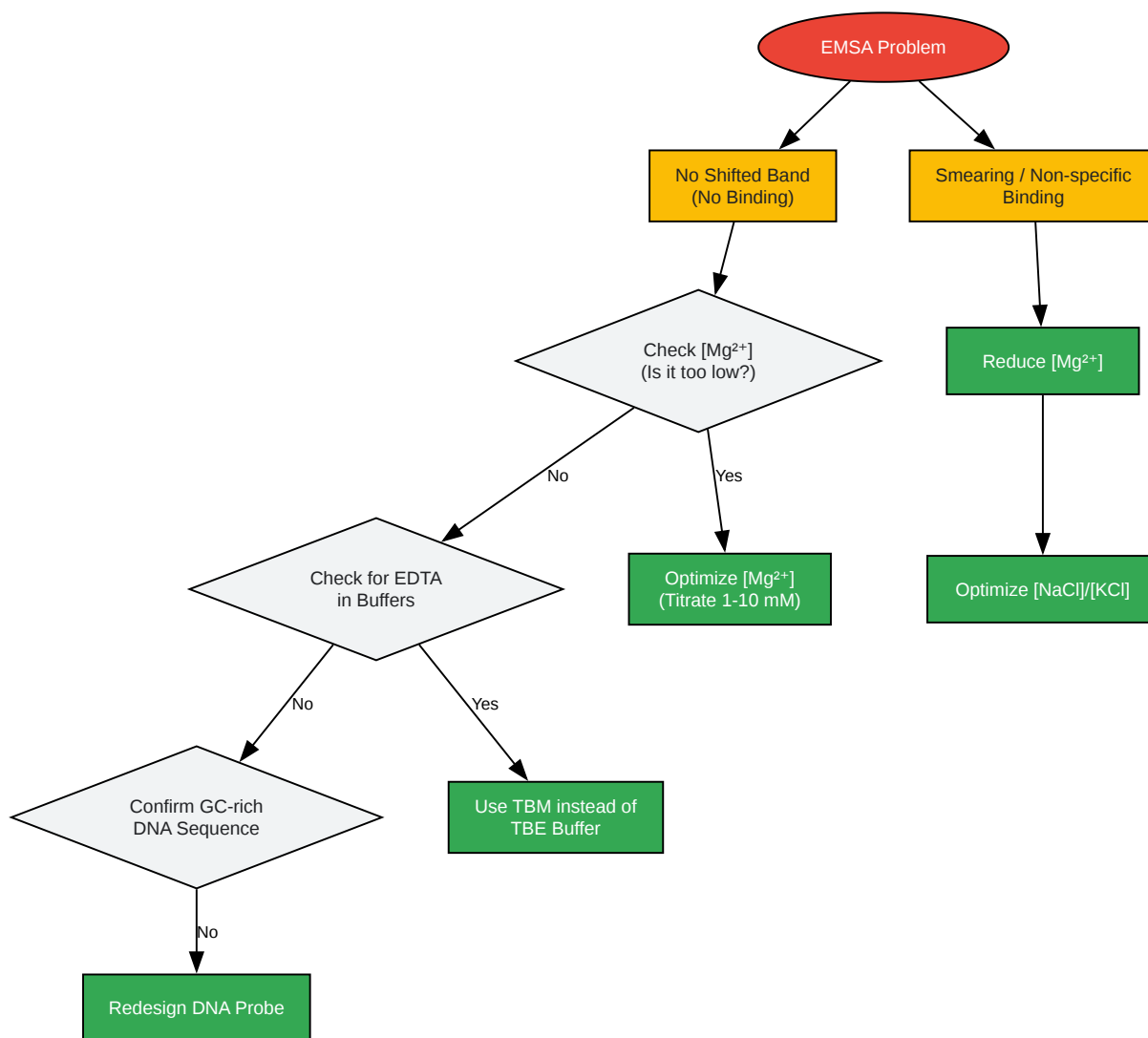

[Click to download full resolution via product page](#)

Caption: Troubleshooting logic for common EMSA issues.

Need Custom Synthesis?

BenchChem offers custom synthesis for rare earth carbides and specific isotopic labeling.

Email: info@benchchem.com or [Request Quote Online](#).

References

- 1. Divalent cations are dispensable for binding to DNA of a novel positively charged olivomycin A derivative - PubMed [pubmed.ncbi.nlm.nih.gov]
- 2. Divalent cations are dispensable for binding to DNA of a novel positively charged olivomycin A derivative - PMC [pmc.ncbi.nlm.nih.gov]
- 3. Discrimination between G/C Binding Sites by Olivomycin A Is Determined by Kinetics of the Drug-DNA Interaction - PMC [pmc.ncbi.nlm.nih.gov]
- 4. Discrimination between G/C Binding Sites by Olivomycin A Is Determined by Kinetics of the Drug-DNA Interaction - PubMed [pubmed.ncbi.nlm.nih.gov]
- 5. Magnesium is required for specific DNA binding of the CREB B-ZIP domain - PMC [pmc.ncbi.nlm.nih.gov]
- 6. researchgate.net [researchgate.net]
- To cite this document: BenchChem. [Technical Support Center: Optimizing Magnesium Concentration for Olivomycin D-DNA Binding]. BenchChem, [2025]. [Online PDF]. Available at: [<https://www.benchchem.com/product/b3344421#magnesium-concentration-optimization-for-olivomycin-d-dna-binding>]

Disclaimer & Data Validity:

The information provided in this document is for Research Use Only (RUO) and is strictly not intended for diagnostic or therapeutic procedures. While BenchChem strives to provide accurate protocols, we make no warranties, express or implied, regarding the fitness of this product for every specific experimental setup.

Technical Support: The protocols provided are for reference purposes. Unsure if this reagent suits your experiment? [[Contact our Ph.D. Support Team for a compatibility check](#)]

Need Industrial/Bulk Grade? [Request Custom Synthesis Quote](#)

BenchChem

Our mission is to be the trusted global source of essential and advanced chemicals, empowering scientists and researchers to drive progress in science and industry.

Contact

Address: 3281 E Guasti Rd
Ontario, CA 91761, United States
Phone: (601) 213-4426
Email: info@benchchem.com