

Technical Support Center: Optimizing LC-MS/MS for GGPP Detection

Author: BenchChem Technical Support Team. **Date:** December 2025

Compound of Interest

Compound Name: Geranylgeranyl pyrophosphate

Cat. No.: B1195527

[Get Quote](#)

Welcome to the technical support center for the LC-MS/MS analysis of **Geranylgeranyl pyrophosphate** (GGPP). This resource is designed for researchers, scientists, and drug development professionals to provide troubleshooting guidance and answers to frequently asked questions, ensuring accurate and reproducible quantification of GGPP in your experiments.

Frequently Asked Questions (FAQs)

Q1: What is the most common ionization mode for GGPP detection by LC-MS/MS?

A1: Electrospray ionization (ESI) in the negative ion mode is the most commonly used and effective method for detecting GGPP.^[1] This is because the phosphate groups on the GGPP molecule are readily deprotonated, forming a [M-H]⁻ ion, which allows for sensitive detection.^[1]

Q2: What are the typical MRM transitions for GGPP?

A2: The most abundant and commonly used precursor-to-product ion transition for GGPP is m/z 449.2 → 79.1.^{[1][2]} The fragment ion at m/z 79 corresponds to the phosphate group [PO₃]⁻. Another transition that is sometimes observed is from the in-source fragment of GGPP (which corresponds to Geranylgeranyl monophosphate or GGP), m/z 369.2 → 79.0.^[3] For confirmation, a qualitative transition of m/z 369.2 > 97.0 can also be monitored.^[3]

Q3: Is a derivatization step necessary for GGPP analysis?

A3: Derivatization is generally not required for the direct detection of GGPP by LC-MS/MS.[1] However, for certain applications or when dealing with complex matrices, derivatization has been used for related compounds to improve chromatographic properties and sensitivity.[4][5] [6] For direct analysis, optimizing the chromatography and mass spectrometry parameters is usually sufficient.

Q4: What kind of HPLC column is recommended for GGPP separation?

A4: A reversed-phase C18 column is commonly and successfully used for the chromatographic separation of GGPP.[1][3] Specific examples include ACCQ-TAG Ultra C18 (1.7 μ m, 100 mm \times 2.1 mm) and Acquity UPLC BEH C18 (2.1 \times 50 mm, 1.7 μ m).[1][3]

Troubleshooting Guide

Issue 1: Poor or No GGPP Signal

- Question: I am not seeing a peak for my GGPP standard or sample. What should I check?
- Answer:
 - Confirm Ionization Mode: Ensure your mass spectrometer is operating in negative electrospray ionization (ESI) mode.[1] GGPP is readily detected as a deprotonated molecule.
 - Check MRM Transitions: Verify that you are monitoring the correct precursor and product ions. The most common transition for GGPP is m/z 449.2 \rightarrow 79.1.[1][2]
 - Optimize Source Conditions: The efficiency of ion generation is critical. Optimize parameters such as capillary voltage, source temperature, and gas flows (nebulizer, drying, and desolvation).[1][3] Refer to the instrument-specific recommendations and the example parameters in the tables below.
 - Assess Sample Integrity: GGPP can be unstable and prone to hydrolysis, especially during sample preparation.[3] Ensure your sample extraction and storage procedures are optimized to minimize degradation. This includes keeping samples cold and minimizing the time between extraction and analysis.

- Consider In-Source Fragmentation: GGPP can lose a phosphate group in the mass spectrometer's source, leading to a prominent ion at m/z 369.2 (corresponding to GGP).[3] If you are not seeing the parent ion at m/z 449.2, try monitoring the transition m/z 369.2 → 79.0.

Issue 2: High Background Noise or Interfering Peaks

- Question: My chromatogram has high background noise and/or peaks that are co-eluting with my GGPP peak. How can I improve this?
- Answer:
 - Improve Chromatographic Separation: The main challenge in GGPP quantification is often interference from endogenous isobaric compounds.[1] Optimizing your HPLC gradient can help resolve GGPP from these interferences.[1] Try adjusting the gradient slope or using a shallower gradient around the expected retention time of GGPP.
 - Optimize Sample Preparation: A thorough sample clean-up is crucial. Consider using solid-phase extraction (SPE) to remove interfering matrix components.[4][6]
 - Mobile Phase Modifiers: The choice of mobile phase additives can significantly impact peak shape and resolution. Using a mobile phase with ammonium carbonate or ammonium hydroxide at an alkaline pH can improve chromatography for pyrophosphates. [1][3]
 - Check for Contamination: Ensure your LC system, solvents, and vials are clean and free from contaminants that might contribute to background noise.

Issue 3: Inconsistent or Poor Peak Shape

- Question: My GGPP peak is showing tailing or is very broad. What can I do to improve it?
- Answer:
 - Mobile Phase pH: The phosphate groups of GGPP can interact with the stationary phase, leading to poor peak shape. Using a mobile phase with an alkaline pH (e.g., around 9-10)

can help to ensure the phosphate groups are fully deprotonated and interact less with the column.[1][3]

- Column Choice: While C18 columns are standard, the specific chemistry of the column can affect peak shape. If problems persist, you could test a different brand or type of C18 column.
- Flow Rate: Optimizing the flow rate can improve peak shape. A lower flow rate often leads to sharper peaks, but at the cost of longer run times.[1][3]

Experimental Protocols

Protocol 1: Sample Preparation from Cell Culture

This protocol is a general guideline and may need to be optimized for specific cell types.

- Cell Harvesting: Aspirate the culture medium and wash the cells with ice-cold phosphate-buffered saline (PBS).
- Lysis and Extraction: Add an appropriate volume of ice-cold extraction solvent (e.g., acetonitrile:water, 80:20 v/v). Scrape the cells and transfer the lysate to a microcentrifuge tube.
- Homogenization: Sonicate the samples on ice to ensure complete cell lysis.
- Protein Precipitation: Centrifuge the lysate at high speed (e.g., 14,000 x g) for 10 minutes at 4°C to pellet the precipitated proteins.
- Supernatant Collection: Carefully collect the supernatant and transfer it to a clean tube for LC-MS/MS analysis.[1]

Protocol 2: LC-MS/MS Analysis of GGPP

This protocol provides a starting point for method development.

- Liquid Chromatography:
 - Column: ACCQ-TAG Ultra C18 (1.7 μm, 100 mm × 2.1 mm I.D.) or equivalent.[1]

- Mobile Phase A: 10 mM ammonium carbonate with 0.1% ammonium hydroxide in water. [\[1\]](#)
- Mobile Phase B: 0.1% ammonium hydroxide in acetonitrile/methanol (75/25).[\[1\]](#)
- Flow Rate: 0.25 mL/min.[\[1\]](#)
- Gradient: A linear gradient from a low percentage of mobile phase B to a high percentage over several minutes. An example gradient is to start at 10% B, increase to 65% B over 7 minutes, then increase to 95% B, hold, and re-equilibrate.[\[1\]](#)
- Mass Spectrometry:
 - Ionization: ESI in negative mode.[\[1\]](#)
 - MRM Transitions: Monitor the transitions outlined in the tables below.
 - Instrument Parameters: Optimize source and compound-specific parameters as detailed in the quantitative data tables.

Quantitative Data Summary

Table 1: Example LC-MS/MS Parameters for GGPP Detection

| Parameter | Setting | Reference |
|------------------------|--|-----------|
| LC System | | |
| Column | ACCQ-TAG Ultra C18 (1.7 μ m, 100 mm \times 2.1 mm I.D.) | [1] |
| Mobile Phase A | 10 mM ammonium carbonate with 0.1% ammonium hydroxide in water | [1] |
| Mobile Phase B | 0.1% ammonium hydroxide in acetonitrile/methanol (75/25) | [1] |
| Flow Rate | 0.25 mL/min | [1] |
| MS System | | |
| Ionization Mode | ESI Negative | [1] |
| Nebulizer Gas Flow | 2.0 L/min | [1] |
| Heating Gas Flow | 10 L/min | [1] |
| Drying Gas Flow | 10 L/min | [1] |
| Interface Temperature | 350 $^{\circ}$ C | [1] |
| Desolvation Line Temp. | 250 $^{\circ}$ C | [1] |
| Heat Block Temperature | 400 $^{\circ}$ C | [1] |

Table 2: GGPP MRM Transitions and Compound Parameters

| Analyte | Precursor Ion (m/z) | Product Ion (m/z) | Collision Energy (V) | Q1 Voltage (V) | Q3 Voltage (V) | Reference |
|-----------------------|---------------------|-------------------|----------------------|----------------------|----------------------|-----------|
| GGPP | 449.2 | 79.1 | Varies by instrument | Varies by instrument | Varies by instrument | [1][2] |
| GGPP (in-source frag) | 369.2 | 79.0 | 21 | 15 | - | [3] |
| GGPP (qualifier) | 369.2 | 97.0 | 19 | 15 | - | [3] |

Visualizations

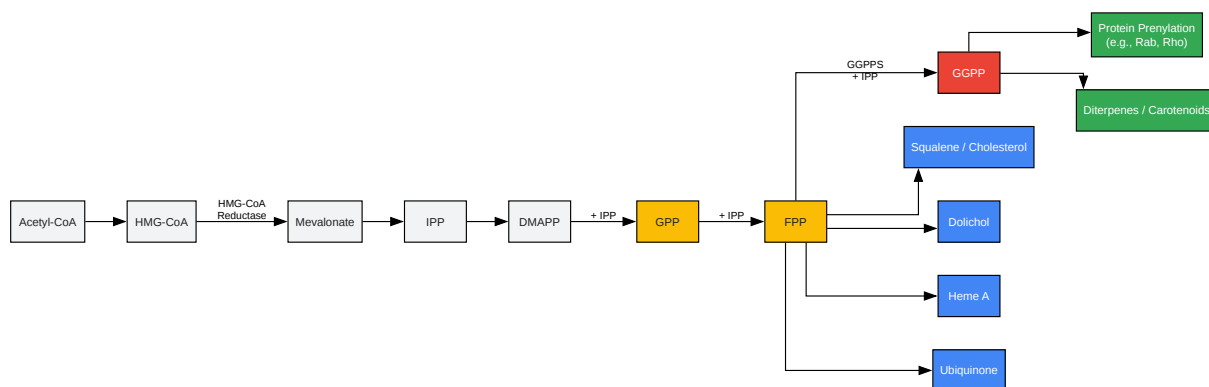

[Click to download full resolution via product page](#)

Caption: The Isoprenoid Biosynthesis Pathway leading to GGPP and its downstream products.

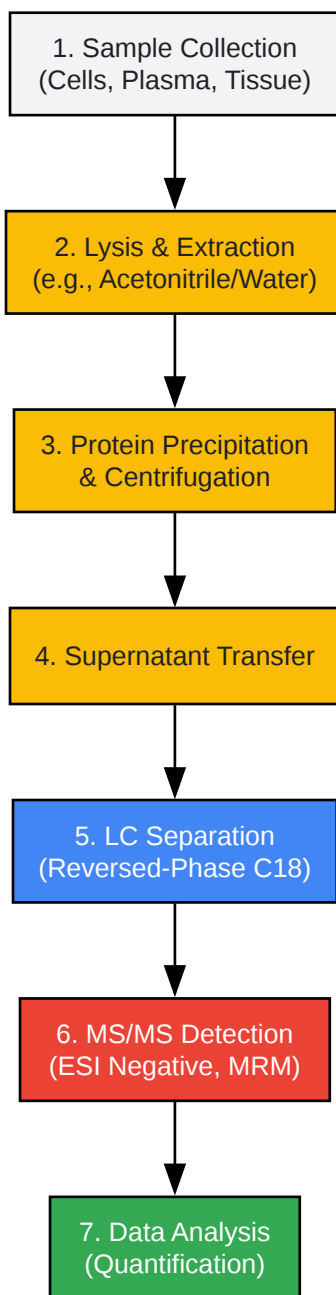

[Click to download full resolution via product page](#)

Caption: A typical experimental workflow for the quantification of GGPP by LC-MS/MS.

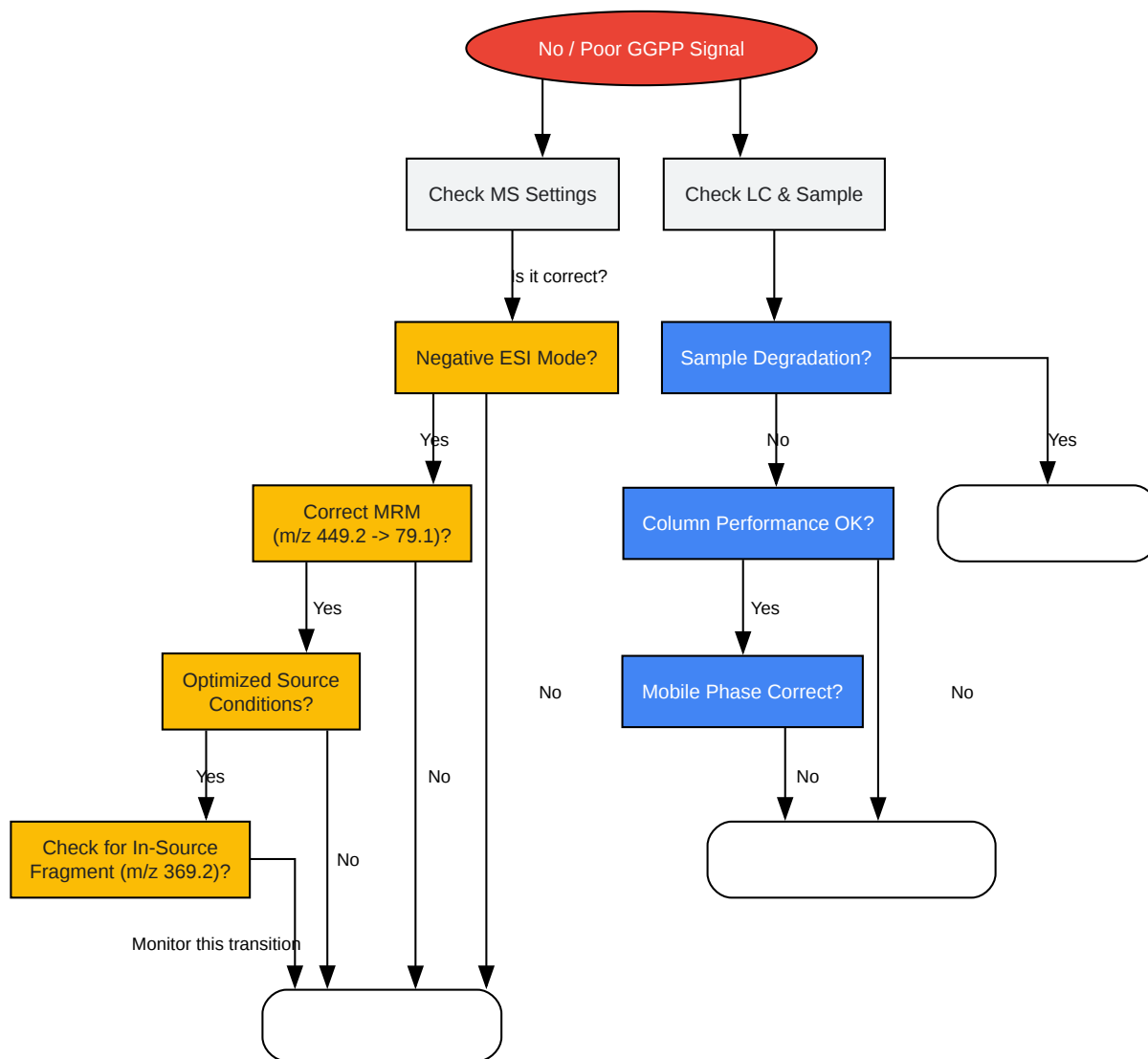

[Click to download full resolution via product page](#)

Caption: A decision tree for troubleshooting common issues in GGPP detection by LC-MS/MS.

Need Custom Synthesis?

BenchChem offers custom synthesis for rare earth carbides and specific isotopic labeling.

Email: info@benchchem.com or [Request Quote Online](#).

References

- 1. Simultaneous Quantitation of Isoprenoid Pyrophosphates in Plasma and Cancer Cells Using LC-MS/MS - PMC [[pmc.ncbi.nlm.nih.gov](https://pubmed.ncbi.nlm.nih.gov)]
- 2. [researchgate.net](https://www.researchgate.net) [[researchgate.net](https://www.researchgate.net)]
- 3. A quantitative method to measure geranylgeranyl diphosphate (GGPP) and geranylgeranyl monophosphate (GGP) in tomato (*Solanum lycopersicum*) fruit - PMC [[pmc.ncbi.nlm.nih.gov](https://pubmed.ncbi.nlm.nih.gov)]
- 4. Quantitative determination of a potent geranylgeranyl diphosphate synthase inhibitor using LC-MS/MS: Derivatization and application - PubMed [pubmed.ncbi.nlm.nih.gov]
- 5. Quantitative Determination of a Potent Geranylgeranyl Diphosphate Synthase Inhibitor using LC- MS/MS: Derivatization and Application - PMC [[pmc.ncbi.nlm.nih.gov](https://pubmed.ncbi.nlm.nih.gov)]
- 6. Research Portal [iro.uiowa.edu]
- To cite this document: BenchChem. [Technical Support Center: Optimizing LC-MS/MS for GGPP Detection]. BenchChem, [2025]. [Online PDF]. Available at: [<https://www.benchchem.com/product/b1195527#optimizing-lc-ms-ms-parameters-for-ggpp-detection>]

Disclaimer & Data Validity:

The information provided in this document is for Research Use Only (RUO) and is strictly not intended for diagnostic or therapeutic procedures. While BenchChem strives to provide accurate protocols, we make no warranties, express or implied, regarding the fitness of this product for every specific experimental setup.

Technical Support: The protocols provided are for reference purposes. Unsure if this reagent suits your experiment? [[Contact our Ph.D. Support Team for a compatibility check](#)]

Need Industrial/Bulk Grade? [Request Custom Synthesis Quote](#)

BenchChem

Our mission is to be the trusted global source of essential and advanced chemicals, empowering scientists and researchers to drive progress in science and industry.

Contact

Address: 3281 E Guasti Rd

Ontario, CA 91761, United States

Phone: (601) 213-4426

Email: info@benchchem.com