

Technical Support Center: Navigating Conflicting Results with SIRT-IN-2

Author: BenchChem Technical Support Team. **Date:** December 2025

Compound of Interest

Compound Name: SIRT-IN-2

Cat. No.: B15588395

[Get Quote](#)

Welcome to the technical support center for **SIRT-IN-2**, a valuable tool for researchers studying the role of SIRT2 in various cellular processes. It is not uncommon to observe divergent or even contradictory outcomes when using a targeted inhibitor like **SIRT-IN-2** across different cell types. This guide is designed to help you understand and troubleshoot these conflicting results.

Frequently Asked Questions (FAQs)

Q1: Why does **SIRT-IN-2**, a SIRT2 inhibitor, show pro-apoptotic effects in some cell lines but not in others?

A1: The pro-apoptotic effect of SIRT2 inhibition is highly context-dependent and often relies on the underlying genetic and molecular landscape of the cell type being studied. Here are key factors to consider:

- **p53 Status:** A primary mechanism by which SIRT2 inhibition can induce apoptosis is through the stabilization and activation of the tumor suppressor protein p53. SIRT2 can deacetylate p53, marking it for degradation. Inhibition of SIRT2 can lead to increased p53 acetylation and subsequent activation of pro-apoptotic target genes.^[1] Therefore, cells with wild-type p53 are more likely to undergo apoptosis in response to **SIRT-IN-2** than cells with mutated or deficient p53.
- **SIRT1 Co-inhibition:** In some cancer cell lines, such as breast carcinoma, the induction of apoptosis requires the simultaneous inhibition of both SIRT1 and SIRT2.^{[1][2]} This is

because both sirtuins can deacetylate and inactivate p53. If SIRT1 activity is high, it may compensate for the inhibition of SIRT2, thus preventing apoptosis.

- Cellular Lineage: Different cell types have distinct survival signaling pathways. For instance, leukemic cell lines have been shown to undergo apoptosis upon treatment with selective SIRT2 inhibitors.[3][4] However, the dependency on specific anti-apoptotic and pro-apoptotic proteins can vary significantly between cell lineages.

Q2: I am seeing cell cycle arrest instead of apoptosis after treating my cells with **SIRT-IN-2**. Why is this happening?

A2: Cell cycle arrest is another common outcome of SIRT2 inhibition and can be considered an alternative cellular response to apoptosis.

- Predominant Cytoplasmic Localization of SIRT2: SIRT2 is primarily found in the cytoplasm, where one of its key substrates is α -tubulin.[5][6] Deacetylation of α -tubulin by SIRT2 is crucial for microtubule dynamics and proper mitotic progression. Inhibition of SIRT2 leads to hyperacetylation of α -tubulin, which can disrupt mitotic spindle formation and lead to cell cycle arrest, often at the G2/M phase.[7]
- Specific Cell Cycle Checkpoints: In some cell types, like multiple myeloma and BV2 microglia, SIRT2 knockdown or inhibition has been specifically shown to induce cell cycle arrest at the G0/G1 phase.[5][8] This suggests that SIRT2 can also influence earlier phases of the cell cycle, potentially through regulation of other cell cycle-associated proteins.

Q3: My experiments with **SIRT-IN-2** are showing conflicting effects on autophagy. Is this expected?

A3: Yes, the role of SIRT2 in autophagy is complex and can be bidirectional, leading to seemingly contradictory results with **SIRT-IN-2**.

- Induction of Autophagy: In some contexts, such as in non-small cell lung cancer (NSCLC) cells, inhibition of SIRT1 and SIRT2 can induce pro-survival autophagy.[9] This is thought to be a compensatory mechanism allowing cells to cope with the stress of sirtuin inhibition.
- Reversal of Dysregulated Autophagy: In other scenarios, such as in immune-tolerant macrophages exposed to high-fat conditions, increased SIRT2 expression leads to impaired

autophagy.[10][11] In this case, treatment with a SIRT2 inhibitor can reverse this dysregulation and restore normal autophagic flux.[10][11]

- Regulation of Autophagic Machinery: SIRT2 can directly interact with and deacetylate several components of the autophagy machinery, including those involved in autophagosome formation and transport.[11] The net effect of SIRT2 inhibition on autophagy will therefore depend on the specific autophagic pathways that are dominant in a given cell type and experimental condition.

Troubleshooting Guide

Issue: Inconsistent or unexpected phenotypic outcomes with **SIRT-IN-2** across different cell lines.

This is a common challenge due to the multifaceted and context-dependent roles of SIRT2.[12] Here's a systematic approach to troubleshoot and interpret your results.

Step 1: Characterize Your Cell Lines

It is crucial to understand the baseline characteristics of the cell lines you are using.

Parameter	Recommended Action	Rationale
SIRT2 Expression Levels	Perform Western blot or qPCR to quantify SIRT2 protein and mRNA levels in your panel of cell lines.	The response to a SIRT2 inhibitor can correlate with the level of SIRT2 expression. Cells with higher SIRT2 levels may be more sensitive to inhibition.
p53 Status	Sequence the TP53 gene or perform a functional p53 assay.	As discussed in the FAQs, p53 status is a critical determinant of the apoptotic response to SIRT2 inhibition.[1]
SIRT1 Expression Levels	Quantify SIRT1 protein and mRNA levels.	High SIRT1 expression may lead to functional redundancy, masking the effects of SIRT2 inhibition, particularly concerning p53-mediated apoptosis.[2]
Baseline Autophagy Levels	Measure baseline autophagic flux using LC3-II turnover assays or Cyto-ID staining.	The existing state of the autophagic machinery can influence how cells respond to SIRT2 inhibition.

Step 2: Verify Target Engagement and Specificity

Ensure that **SIRT-IN-2** is effectively inhibiting SIRT2 in your experimental system.

Parameter	Recommended Action	Rationale
α -tubulin Acetylation	Perform Western blot for acetylated α -tubulin (a primary substrate of SIRT2).	An increase in acetylated α -tubulin is a direct indicator of SIRT2 inhibition in the cytoplasm.
Dose-Response Curve	Determine the IC50 of SIRT-IN-2 for cell viability in your specific cell lines.	The effective concentration of the inhibitor can vary between cell types.
Off-Target Effects	Consider using another structurally different SIRT2 inhibitor as a control. Also, evaluate the acetylation status of known SIRT1 substrates (if relevant).	This helps to confirm that the observed phenotype is due to SIRT2 inhibition and not off-target effects of the specific compound.

Step 3: Analyze Downstream Signaling Pathways

Investigate the key signaling pathways that are modulated by SIRT2.

Pathway	Recommended Action	Rationale
Apoptosis Pathway	Measure cleavage of caspase-3 and PARP, and perform Annexin V/PI staining.	To confirm if the observed cell death is due to apoptosis.
Cell Cycle Pathway	Perform cell cycle analysis by flow cytometry (e.g., propidium iodide staining).	To determine if the inhibitor is causing arrest at a specific phase of the cell cycle.
RAS/ERK and PI3K/Akt Pathways	Analyze the phosphorylation status of key components of these pathways (e.g., ERK, Akt) by Western blot.	SIRT2 has been shown to regulate these critical cell survival and proliferation pathways.[5]

Quantitative Data Summary

The following table summarizes the inhibitory concentrations (IC₅₀) of various SIRT2 inhibitors from the literature to provide a comparative context for your experiments. Note that these values are highly dependent on the specific assay conditions and cell lines used.

Inhibitor	Target(s)	IC ₅₀ (SIRT2)	IC ₅₀ (SIRT1)	Cell Line(s)	Reference
AEM2	SIRT2	3.8 μM	Weak inhibition	Non-small cell lung cancer	[1]
AGK2	SIRT2	3.5 μM	>50 μM	HeLa	[13]
SirReal2	SIRT2	0.23 μM	-	-	[14]
Tenovin-6	SIRT1/SIRT2	Similar IC ₅₀ for both	Similar IC ₅₀ for both	-	[14]
TM	SIRT2	Potent	~26 μM	Cancer cell lines	[14]
Sirtinol	SIRT1/SIRT2	-	-	MCF-7	[2]
Salermide	SIRT1/SIRT2	-	-	MCF-7	[2]
EX527	SIRT1	Weak inhibition	38-98 nM	MCF-7	[2][13]

Experimental Protocols

Protocol 1: Western Blot for Acetylated α-Tubulin

- Cell Treatment: Plate cells and treat with **SIRT-IN-2** at various concentrations for the desired time. Include a vehicle control.
- Cell Lysis: Wash cells with ice-cold PBS and lyse in RIPA buffer supplemented with protease and deacetylase inhibitors (including trichostatin A and nicotinamide).
- Protein Quantification: Determine protein concentration using a BCA assay.

- **SDS-PAGE and Transfer:** Separate equal amounts of protein on an SDS-polyacrylamide gel and transfer to a PVDF membrane.
- **Antibody Incubation:** Block the membrane and incubate with a primary antibody against acetylated α -tubulin. Also, probe a separate membrane or strip and re-probe the same membrane with an antibody against total α -tubulin or a loading control (e.g., GAPDH, β -actin).
- **Detection:** Use an appropriate HRP-conjugated secondary antibody and a chemiluminescent substrate to detect the protein bands.
- **Analysis:** Quantify the band intensities and normalize the acetylated α -tubulin signal to the total α -tubulin or loading control signal.

Protocol 2: Cell Cycle Analysis by Propidium Iodide Staining

- **Cell Treatment and Harvesting:** Treat cells with **SIRT-IN-2** as required. Harvest the cells by trypsinization, wash with PBS, and collect the cell pellet.
- **Fixation:** Resuspend the cell pellet in ice-cold 70% ethanol while vortexing gently to prevent clumping. Fix the cells overnight at -20°C .
- **Staining:** Centrifuge the fixed cells, discard the ethanol, and wash with PBS. Resuspend the cell pellet in a staining solution containing propidium iodide (PI) and RNase A.
- **Flow Cytometry:** Incubate for 30 minutes at room temperature in the dark. Analyze the DNA content of the cells using a flow cytometer.
- **Data Analysis:** Use appropriate software to deconvolute the DNA content histograms and determine the percentage of cells in the G0/G1, S, and G2/M phases of the cell cycle.

Visualizations

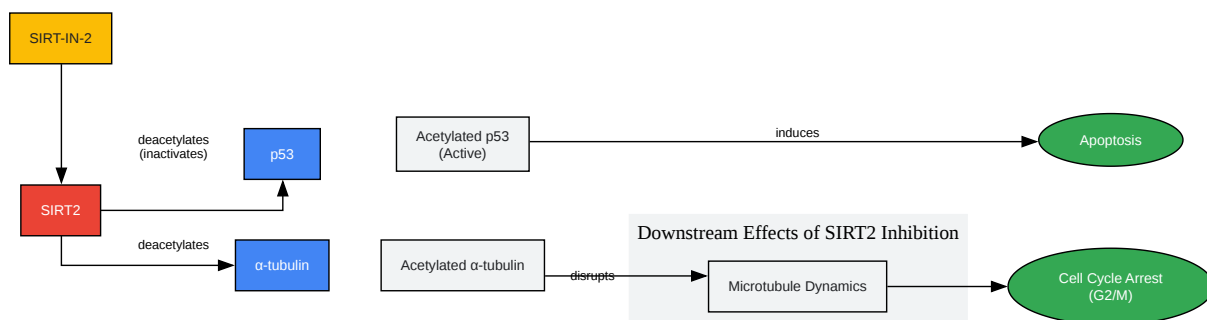

[Click to download full resolution via product page](#)

Caption: Core signaling pathways affected by SIRT2 inhibition.

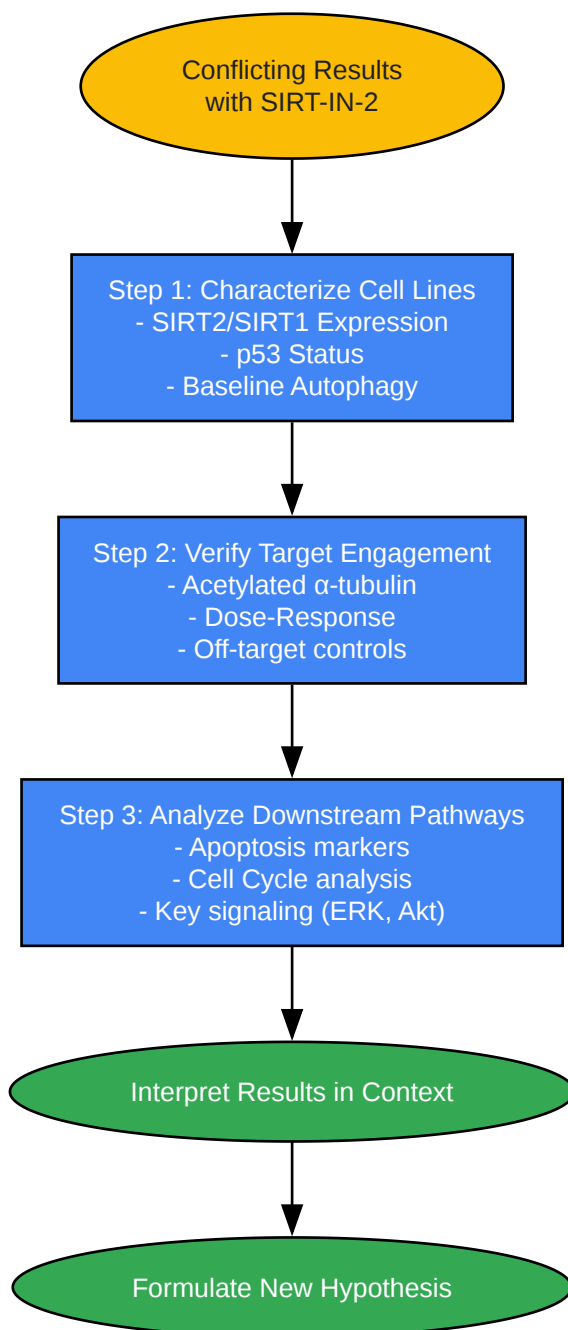

[Click to download full resolution via product page](#)

Caption: A logical workflow for troubleshooting conflicting results.

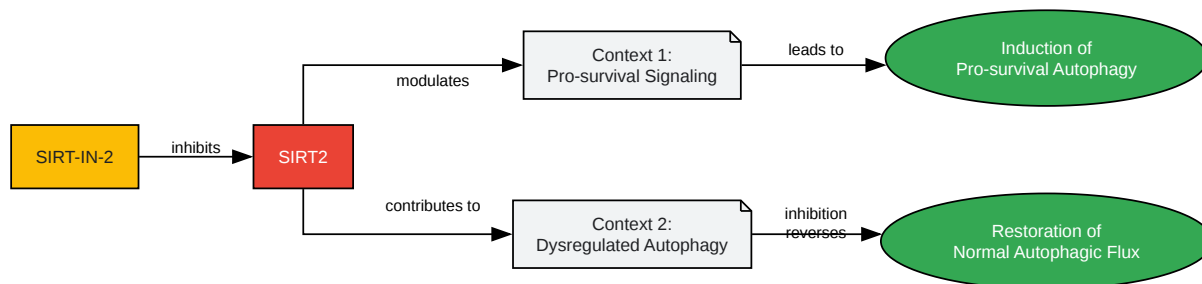

[Click to download full resolution via product page](#)

Caption: The dual role of SIRT2 inhibition in autophagy.

Need Custom Synthesis?

BenchChem offers custom synthesis for rare earth carbides and specific isotopic labeling.

Email: info@benchchem.com or [Request Quote Online](#).

References

- 1. A Novel Sirtuin 2 (SIRT2) Inhibitor with p53-dependent Pro-apoptotic Activity in Non-small Cell Lung Cancer - PMC [pmc.ncbi.nlm.nih.gov]
- 2. aacrjournals.org [aacrjournals.org]
- 3. Novel small molecule SIRT2 inhibitors induce cell death in leukemic cell lines | springermedizin.de [springermedizin.de]
- 4. Novel small molecule SIRT2 inhibitors induce cell death in leukemic cell lines - PMC [pmc.ncbi.nlm.nih.gov]
- 5. Sirtuin 2 knockdown inhibits cell proliferation and RAS/ERK signaling, and promotes cell apoptosis and cell cycle arrest in multiple myeloma - PMC [pmc.ncbi.nlm.nih.gov]
- 6. Sirtuin 2 (SIRT2): Confusing Roles in the Pathophysiology of Neurological Disorders - PMC [pmc.ncbi.nlm.nih.gov]
- 7. The Clinical Significance of SIRT2 in Malignancies: A Tumor Suppressor or an Oncogene? - PMC [pmc.ncbi.nlm.nih.gov]

- 8. SIRT2 plays a key role in both cell cycle regulation and cell survival of BV2 microglia - PMC [pmc.ncbi.nlm.nih.gov]
- 9. researchgate.net [researchgate.net]
- 10. Sirtuin 2 Dysregulates Autophagy in High-Fat-Exposed Immune-Tolerant Macrophages - PubMed [pubmed.ncbi.nlm.nih.gov]
- 11. mdpi.com [mdpi.com]
- 12. Sirtuin 2 - Wikipedia [en.wikipedia.org]
- 13. mdpi.com [mdpi.com]
- 14. Direct Comparison of SIRT2 Inhibitors: Potency, Specificity, Activity-Dependent Inhibition, and On-Target Anticancer Activities - PMC [pmc.ncbi.nlm.nih.gov]
- To cite this document: BenchChem. [Technical Support Center: Navigating Conflicting Results with SIRT-IN-2]. BenchChem, [2025]. [Online PDF]. Available at: [https://www.benchchem.com/product/b15588395#addressing-conflicting-results-with-sirt-in-2-in-different-cell-types]

Disclaimer & Data Validity:

The information provided in this document is for Research Use Only (RUO) and is strictly not intended for diagnostic or therapeutic procedures. While BenchChem strives to provide accurate protocols, we make no warranties, express or implied, regarding the fitness of this product for every specific experimental setup.

Technical Support: The protocols provided are for reference purposes. Unsure if this reagent suits your experiment? [[Contact our Ph.D. Support Team for a compatibility check](#)]

Need Industrial/Bulk Grade? [Request Custom Synthesis Quote](#)

BenchChem

Our mission is to be the trusted global source of essential and advanced chemicals, empowering scientists and researchers to drive progress in science and industry.

Contact

Address: 3281 E Guasti Rd
Ontario, CA 91761, United States
Phone: (601) 213-4426
Email: info@benchchem.com

