

# Technical Support Center: Isostearyl Oleate Degradation Analysis

**Author:** BenchChem Technical Support Team. **Date:** December 2025

## Compound of Interest

Compound Name: *Isostearyl oleate*

Cat. No.: *B14609947*

[Get Quote](#)

This technical support center provides researchers, scientists, and drug development professionals with comprehensive troubleshooting guides and frequently asked questions (FAQs) regarding the degradation of **isostearyl oleate**.

## Frequently Asked Questions (FAQs)

Q1: What are the primary degradation pathways for **isostearyl oleate**?

A1: **Isostearyl oleate** can degrade through three primary pathways:

- **Hydrolysis:** This involves the cleavage of the ester bond in the presence of water, yielding isostearyl alcohol and oleic acid. This process can be accelerated by acidic or basic conditions.
- **Oxidation:** The primary site of oxidation is the double bond within the oleic acid moiety. This can lead to the formation of a complex mixture of byproducts, including aldehydes, ketones, and shorter-chain carboxylic acids. The presence of oxygen, light, and metal ions can catalyze oxidation.
- **Thermal Degradation:** At elevated temperatures, **isostearyl oleate** can undergo complex degradation reactions. This can involve isomerization, dechlorination (if chlorine is present), and deacylation, leading to a variety of breakdown products.<sup>[1][2]</sup>

Q2: What are the expected byproducts of **isostearyl oleate** degradation?

A2: The expected byproducts depend on the degradation pathway:

- Hydrolysis: The main byproducts are isostearyl alcohol and oleic acid.
- Oxidation: A variety of compounds can be formed, including:
  - Aldehydes (e.g., nonanal)
  - Ketones
  - Epoxides
  - Hydroxy acids
  - Shorter-chain mono- and dicarboxylic acids (e.g., azelaic acid, nonanoic acid)<sup>[3][4]</sup>
- Thermal Degradation: The byproducts can be numerous and varied, including isomers of **isostearyl oleate**, and products of dechlorination and deacylation if relevant catalysts or conditions are present.<sup>[1][2]</sup>

Q3: How can I minimize the degradation of **isostearyl oleate** during storage and experimentation?

A3: To minimize degradation, consider the following:

- Storage: Store **isostearyl oleate** in a cool, dark place in a well-sealed container to protect it from heat, light, and oxygen. Purging the container with an inert gas like nitrogen or argon can also help.
- Handling: Minimize exposure to air and light during experiments. Use antioxidants if compatible with your experimental design.
- pH Control: Maintain a neutral pH to minimize acid- or base-catalyzed hydrolysis.
- Metal Contamination: Avoid contact with metal surfaces that can catalyze oxidation. Use glass or inert plastic labware where possible.

Q4: What analytical techniques are best suited for studying **isostearyl oleate** degradation?

A4: A combination of chromatographic and spectroscopic techniques is often employed:

- High-Performance Liquid Chromatography (HPLC): Useful for separating **isostearyl oleate** from its non-volatile degradation products. A variety of detectors can be used, including UV-Vis, Refractive Index (RI), and Mass Spectrometry (MS).
- Gas Chromatography-Mass Spectrometry (GC-MS): Ideal for identifying volatile byproducts of oxidation and thermal degradation.<sup>[5]</sup>
- Thermogravimetric Analysis-Fourier Transform Infrared Spectroscopy (TG-FTIR): Can be used to study the thermal degradation process and identify the evolved gaseous products.<sup>[6]</sup>

## Troubleshooting Guides

### Guide 1: Unexpected Peaks in HPLC Chromatogram

Problem	Possible Cause	Recommended Solution
Appearance of early eluting peaks.	Hydrolysis of isostearyl oleate to the more polar isostearyl alcohol and oleic acid.	- Check the pH of your sample and mobile phase. - Ensure your sample was not exposed to high humidity or water. - Prepare fresh samples and analyze them promptly.
Appearance of multiple, poorly resolved peaks.	Oxidative degradation leading to a complex mixture of byproducts.	- Check for sources of oxygen or metal ion contamination. - Store samples under an inert atmosphere and protect them from light. - Consider adding an antioxidant to your sample if it does not interfere with the analysis.
Ghost peaks or baseline instability.	Contamination from the mobile phase or sample carryover.	- Filter all mobile phases and use high-purity solvents. - Implement a robust column washing procedure between injections. - Check for buffer precipitation, especially when mixing with organic solvents.

## Guide 2: Inconsistent Results in Stability Studies

Problem	Possible Cause	Recommended Solution
High variability between replicate samples.	Inconsistent sample handling and storage.	<ul style="list-style-type: none"><li>- Standardize your sample preparation procedure.</li><li>- Ensure all samples are stored under identical conditions.</li><li>- Minimize the time between sample preparation and analysis.</li></ul>
Accelerated degradation compared to expectations.	Uncontrolled environmental factors.	<ul style="list-style-type: none"><li>- Verify the temperature and humidity control of your stability chambers.</li><li>- Protect samples from light exposure, even within the chamber.</li><li>- Ensure the container closure system is appropriate and properly sealed.</li></ul>
Difficulty in identifying degradation products.	Co-elution of byproducts or lack of appropriate analytical standards.	<ul style="list-style-type: none"><li>- Optimize your HPLC or GC method to improve peak resolution.</li><li>- Use mass spectrometry (LC-MS or GC-MS) for structural elucidation of unknown peaks.</li><li>- Perform forced degradation studies to generate potential degradation products for use as references.</li></ul> <p>[7]</p>

## Experimental Protocols

### Protocol 1: Forced Degradation Study of Isostearyl Oleate

Objective: To intentionally degrade **isostearyl oleate** under various stress conditions to identify potential degradation pathways and byproducts. This information is crucial for developing stability-indicating analytical methods.

### Methodology:

- **Sample Preparation:** Prepare a stock solution of **isostearyl oleate** in a suitable solvent (e.g., acetonitrile or isopropanol) at a known concentration (e.g., 1 mg/mL).
- **Stress Conditions:**
  - **Acid Hydrolysis:** Mix the stock solution with an equal volume of 0.1 M HCl. Incubate at 60°C for 24 hours.
  - **Base Hydrolysis:** Mix the stock solution with an equal volume of 0.1 M NaOH. Incubate at 60°C for 24 hours.<sup>[8][9]</sup>
  - **Oxidation:** Mix the stock solution with an equal volume of 3% hydrogen peroxide. Store at room temperature, protected from light, for 24 hours.
  - **Thermal Degradation:** Place a sample of pure **isostearyl oleate** in an oven at 180°C for 12 hours.<sup>[10]</sup> After cooling, dissolve in the chosen solvent.
  - **Photodegradation:** Expose the stock solution to a light source (e.g., a photostability chamber) for a defined period.
- **Sample Analysis:**
  - Before analysis, neutralize the acid and base-hydrolyzed samples.
  - Analyze all stressed samples, along with an unstressed control sample, using a suitable analytical method like HPLC-UV/MS.
- **Data Evaluation:**
  - Compare the chromatograms of the stressed samples to the control.
  - Identify and quantify the degradation products.
  - Use mass spectrometry data to propose structures for the unknown byproducts.

## Protocol 2: HPLC Method for Analysis of Isostearyl Oleate and its Degradation Products

Objective: To separate and quantify **isostearyl oleate** and its primary non-volatile degradation products.

Methodology:

- Instrumentation: A standard HPLC system with a UV or RI detector. An LC-MS system is recommended for peak identification.
- Column: A C18 reverse-phase column (e.g., 4.6 x 250 mm, 5  $\mu$ m).
- Mobile Phase: A gradient elution is typically required.
  - Solvent A: Water
  - Solvent B: Acetonitrile
  - Gradient: Start with 80% B, increase to 100% B over 20 minutes, hold for 10 minutes, then return to initial conditions.
- Flow Rate: 1.0 mL/min.
- Column Temperature: 30°C.
- Injection Volume: 10  $\mu$ L.
- Detector:
  - UV at 205 nm (for the ester carbonyl group).
  - Refractive Index (RI) for universal detection.
  - Mass Spectrometer for identification.
- Sample Preparation: Dilute the sample in the mobile phase or a compatible solvent.

## Quantitative Data Summary

The following tables provide an example of how to present quantitative data from a forced degradation study of **isostearyl oleate**. The values are hypothetical and for illustrative purposes only.

Table 1: Summary of **Isostearyl Oleate** Degradation under Forced Conditions

Stress Condition	% Isostearyl Oleate Remaining	Total % Degradation Products
Control (Unstressed)	99.8%	0.2%
0.1 M HCl, 60°C, 24h	85.2%	14.8%
0.1 M NaOH, 60°C, 24h	78.9%	21.1%
3% H <sub>2</sub> O <sub>2</sub> , RT, 24h	92.5%	7.5%
180°C, 12h	65.1%	34.9%

Table 2: Profile of Major Degradation Byproducts (Hypothetical Data)

Byproduct	Hydrolysis (Acidic)	Oxidation	Thermal
Isostearyl Alcohol	7.2%	< 0.1%	5.4%
Oleic Acid	7.5%	< 0.1%	6.1%
9-Oxononanoic Acid	Not Detected	2.8%	1.5%
Azelaic Acid	Not Detected	1.9%	0.8%
Nonanal	Not Detected	1.2%	0.5%
Other Unknowns	0.1%	1.6%	20.6%

## Visualizations



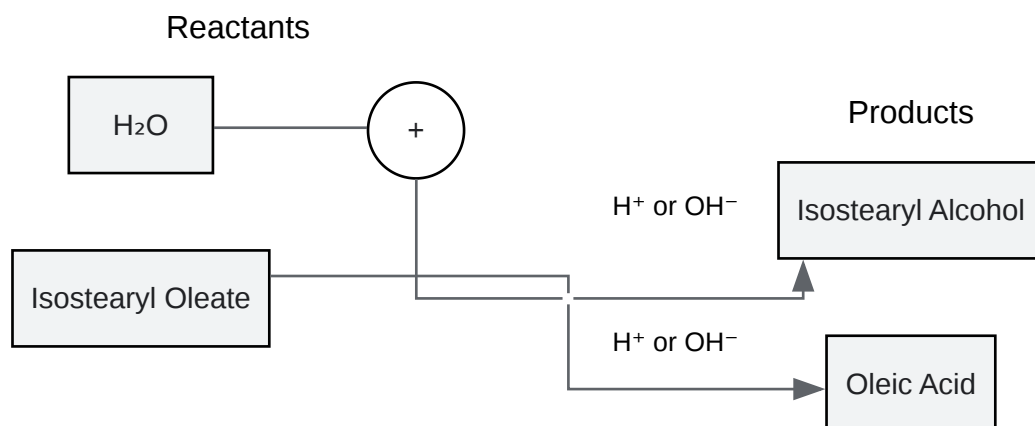

[Click to download full resolution via product page](#)

Caption: Hydrolytic degradation pathway of **isostearyl oleate**.

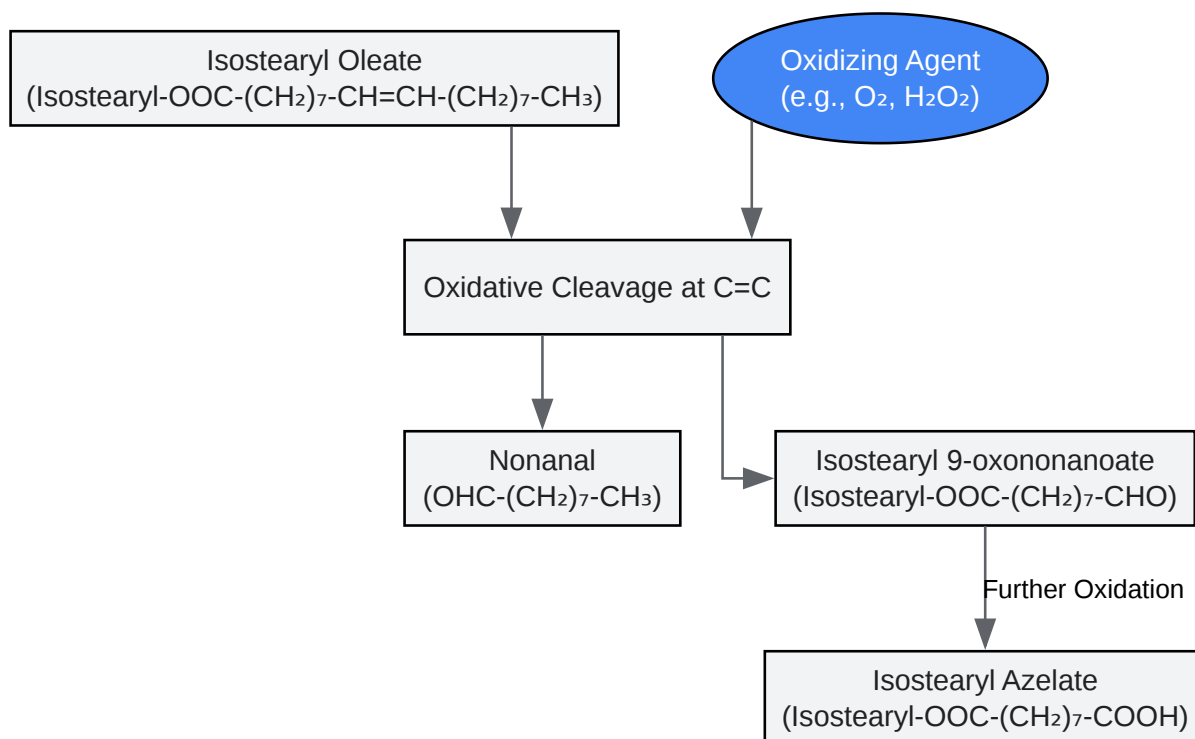

[Click to download full resolution via product page](#)

Caption: Simplified oxidative degradation of **isostearyl oleate**.

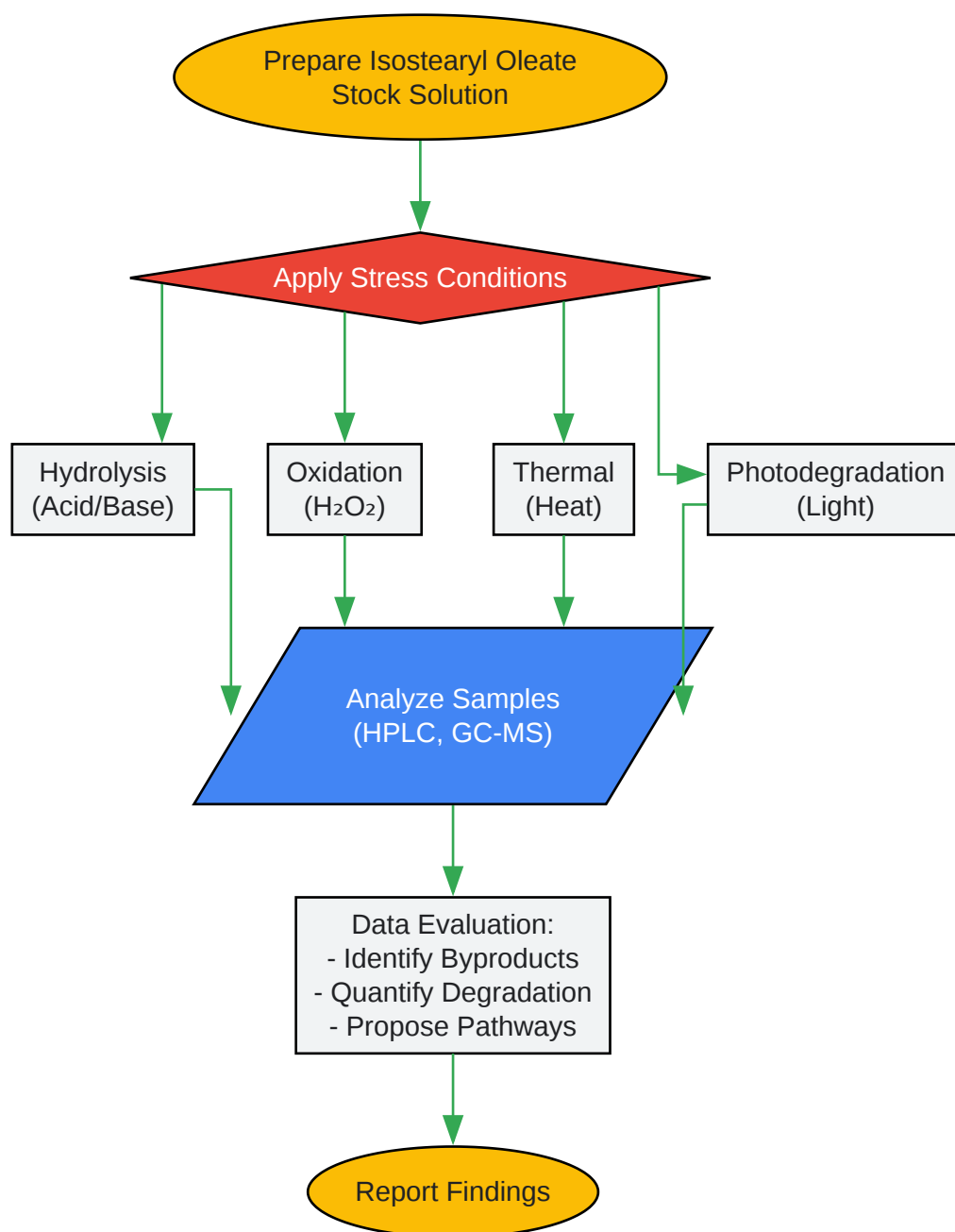

[Click to download full resolution via product page](#)

Caption: Workflow for a forced degradation study.

### Need Custom Synthesis?

BenchChem offers custom synthesis for rare earth carbides and specific isotopic labeling.

Email: [info@benchchem.com](mailto:info@benchchem.com) or [Request Quote Online](#).

## References

- 1. Study on the thermal degradation of 3-MCPD esters in model systems simulating deodorization of vegetable oils - PubMed [pubmed.ncbi.nlm.nih.gov]
- 2. researchgate.net [researchgate.net]
- 3. mdpi.com [mdpi.com]
- 4. Structural analysis of oligomeric molecules formed from the reaction products of oleic acid ozonolysis - PubMed [pubmed.ncbi.nlm.nih.gov]
- 5. drchristinegrant.wordpress.ncsu.edu [drchristinegrant.wordpress.ncsu.edu]
- 6. researchgate.net [researchgate.net]
- 7. How To Overcome The Critical Challenges Faced In Forced Degradation Studies | Lhasa Limited [lhasalimited.org]
- 8. reddit.com [reddit.com]
- 9. Quantitative release of fatty acids from lipids by a simple hydrolysis procedure - PubMed [pubmed.ncbi.nlm.nih.gov]
- 10. Effect of Fatty Acid Unsaturation on Phytosteryl Ester Degradation - PubMed [pubmed.ncbi.nlm.nih.gov]
- To cite this document: BenchChem. [Technical Support Center: Isostearyl Oleate Degradation Analysis]. BenchChem, [2025]. [Online PDF]. Available at: [https://www.benchchem.com/product/b14609947#isostearyl-oleate-degradation-pathways-and-byproducts]

---

### Disclaimer & Data Validity:

The information provided in this document is for Research Use Only (RUO) and is strictly not intended for diagnostic or therapeutic procedures. While BenchChem strives to provide accurate protocols, we make no warranties, express or implied, regarding the fitness of this product for every specific experimental setup.

**Technical Support:** The protocols provided are for reference purposes. Unsure if this reagent suits your experiment? [[Contact our Ph.D. Support Team for a compatibility check](#)]

**Need Industrial/Bulk Grade?** [Request Custom Synthesis Quote](#)

# BenchChem

Our mission is to be the trusted global source of essential and advanced chemicals, empowering scientists and researchers to drive progress in science and industry.

## Contact

Address: 3281 E Guasti Rd

Ontario, CA 91761, United States

Phone: (601) 213-4426

Email: [info@benchchem.com](mailto:info@benchchem.com)