

Technical Support Center: Interpreting Unexpected Results in NGP555 Experiments

Author: BenchChem Technical Support Team. **Date:** December 2025

Compound of Interest

Compound Name: NGP555

Cat. No.: B609552

[Get Quote](#)

This technical support center provides troubleshooting guides and frequently asked questions (FAQs) for researchers, scientists, and drug development professionals encountering unexpected results during experiments with **NGP555**, a γ -secretase modulator.

Frequently Asked Questions (FAQs)

Q1: What is the expected effect of **NGP555** on amyloid-beta ($A\beta$) peptide levels?

NGP555 is a γ -secretase modulator (GSM) that selectively alters the activity of γ -secretase, the enzyme responsible for the final cleavage of the amyloid precursor protein (APP). The expected outcome is a shift in the production of $A\beta$ peptides, specifically a decrease in the longer, more amyloidogenic forms ($A\beta_{42}$ and $A\beta_{40}$) and a corresponding increase in the shorter, less aggregation-prone forms ($A\beta_{38}$ and $A\beta_{37}$)[1]. Unlike γ -secretase inhibitors (GSIs), **NGP555** is not expected to inhibit the overall proteolytic activity of γ -secretase, and therefore should not significantly affect the total levels of $A\beta$ peptides or the processing of other γ -secretase substrates like Notch[1][2].

Q2: We are not observing the expected decrease in $A\beta_{42}$ and increase in $A\beta_{38}$ in our cell-based assay. What are the possible reasons?

Several factors could contribute to this. Please refer to the troubleshooting guide below for a systematic approach to identifying the issue. Common causes include suboptimal cell culture conditions, incorrect **NGP555** concentration, or issues with the $A\beta$ quantification assay.

Q3: Is **NGP555** expected to be cytotoxic? We are observing increased cell death at higher concentrations.

While **NGP555** has been developed to have an adequate safety margin, all compounds can exhibit cytotoxicity at high concentrations[1]. It is crucial to determine the optimal, non-toxic working concentration for your specific cell line through a dose-response experiment. If you observe cytotoxicity within the expected efficacious concentration range, it could indicate an issue with the compound's purity, the vehicle used for solubilization, or the health of your cell culture.

Q4: We are seeing significant variability in our in vivo study results with **NGP555**. How can we reduce this?

In vivo studies are inherently more variable than in vitro assays. Factors such as animal age, sex, genetic background, and the formulation and administration of **NGP555** can all contribute to variability[1]. Ensuring consistent experimental procedures, using appropriate sample sizes, and carefully monitoring animal health are critical. Refer to the in vivo troubleshooting guide for more specific recommendations.

Troubleshooting Guides

Issue 1: No significant change in $A\beta_{42}/A\beta_{38}$ ratio in cell-based assays

Possible Cause	Troubleshooting Steps	Expected Outcome
Incorrect NGP555 Concentration	Perform a dose-response curve to determine the optimal concentration for your cell line. We recommend starting with a range from 1 nM to 10 μ M.	A clear dose-dependent decrease in the A β 42/A β 38 ratio.
Suboptimal Cell Health	Ensure cells are healthy, within a low passage number, and not overgrown at the time of treatment. Perform a cell viability assay in parallel.	Healthy cells should exhibit a robust response to NGP555.
Inappropriate Cell Line	Confirm that your cell line expresses endogenous or overexpressed APP and the necessary components of the γ -secretase complex. SH-SY5Y-APP cells are a commonly used model[1].	A responsive cell line is essential for observing the modulatory effects of NGP555.
Issues with A β Quantification	Verify the specificity and sensitivity of your ELISA kit for the different A β isoforms. Run standard curves and quality controls with every assay. Consider using an alternative method like Meso Scale Discovery (MSD) for confirmation[1].	Accurate and reproducible quantification of A β isoforms.
Compound Degradation	Ensure proper storage and handling of NGP555. Prepare fresh stock solutions and dilute to the final concentration immediately before use.	Consistent results with freshly prepared compound.

Issue 2: High variability in in vivo A β measurements

Possible Cause	Troubleshooting Steps	Expected Outcome
Inconsistent Dosing	Ensure accurate and consistent oral gavage or other administration methods. Use a well-homogenized formulation. NGP555 has been administered in 80% PEG for rodent studies[1].	Reduced variability in plasma and CSF drug concentrations.
Sample Collection and Processing	Standardize the timing of sample collection post-dose. Process brain, plasma, and CSF samples consistently and store them at -80°C. Avoid repeated freeze-thaw cycles.	Minimized sample degradation and consistent A β measurements.
Inter-animal Variability	Use a sufficient number of animals per group to achieve statistical power. Ensure animals are age and sex-matched.	Statistically significant differences between treatment and vehicle groups.
Analytical Assay Variability	Run samples from the same study in the same assay batch to minimize inter-assay variability. Include internal controls and standards in every plate.	Reduced coefficient of variation (CV) for A β measurements.

Experimental Protocols

Protocol 1: In Vitro NGP555 Treatment and A β Quantification

- Cell Culture: Plate SH-SY5Y cells stably overexpressing human APP695 (SH-SY5Y-APP) in 24-well plates at a density that allows for 70-80% confluency after 24 hours.

- **NGP555** Preparation: Prepare a 10 mM stock solution of **NGP555** in DMSO. Serially dilute the stock solution in cell culture media to achieve the desired final concentrations.
- Cell Treatment: Remove the existing media from the cells and replace it with media containing the various concentrations of **NGP555** or a vehicle control (e.g., 0.1% DMSO). Incubate for 18-24 hours.
- Sample Collection: Collect the conditioned media from each well. Centrifuge at 1,000 x g for 5 minutes to pellet any detached cells and collect the supernatant.
- A β Quantification: Analyze the levels of A β 38, A β 40, and A β 42 in the conditioned media using a commercially available ELISA or MSD kit according to the manufacturer's instructions[1].
- Data Analysis: Calculate the ratio of A β 42 to A β 38 and A β 40 to A β 38 for each treatment condition. Normalize the results to the vehicle control.

Mandatory Visualizations

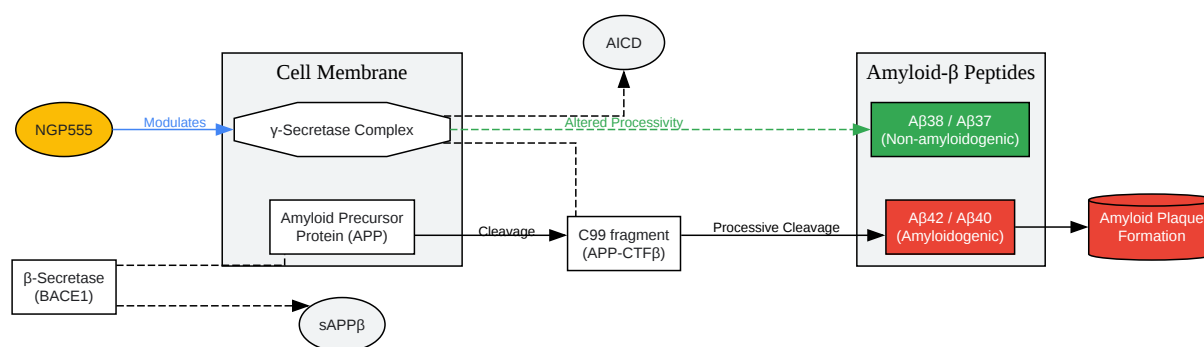

[Click to download full resolution via product page](#)

Caption: **NGP555** modulates γ -secretase to shift APP processing towards non-amyloidogenic A β peptides.

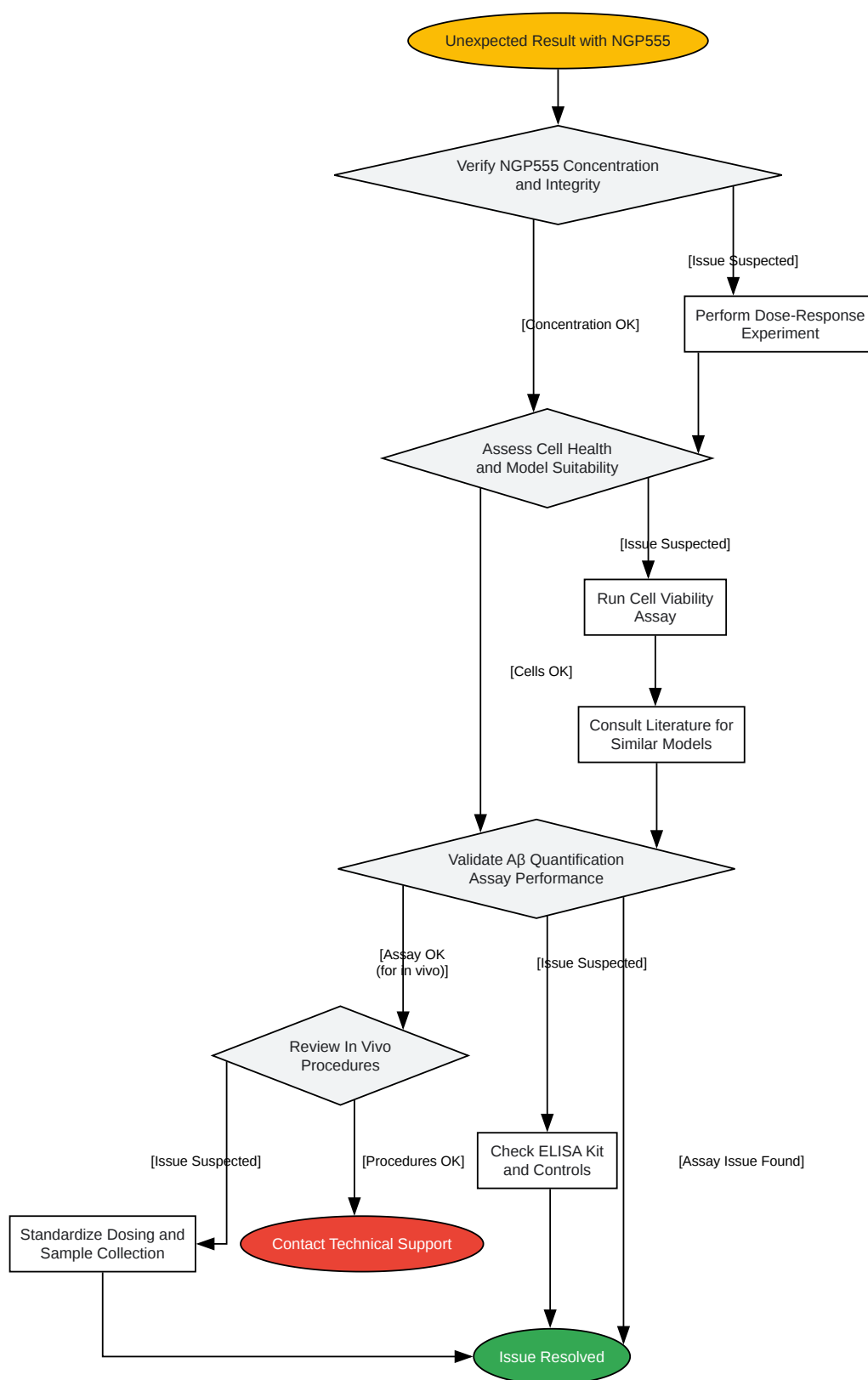

[Click to download full resolution via product page](#)

Caption: A logical workflow for troubleshooting unexpected experimental results with **NGP555**.

Need Custom Synthesis?

BenchChem offers custom synthesis for rare earth carbides and specific isotopic labeling.

Email: info@benchchem.com or [Request Quote Online](#).

References

- 1. NGP 555, a γ -secretase modulator, lowers the amyloid biomarker, A β 42, in cerebrospinal fluid while preventing Alzheimer's disease cognitive decline in rodents - PMC [pmc.ncbi.nlm.nih.gov]
- 2. Gamma-secretase modulators: a promising route for the treatment of Alzheimer's disease - PMC [pmc.ncbi.nlm.nih.gov]
- To cite this document: BenchChem. [Technical Support Center: Interpreting Unexpected Results in NGP555 Experiments]. BenchChem, [2025]. [Online PDF]. Available at: [https://www.benchchem.com/product/b609552#interpreting-unexpected-results-in-ngp555-experiments]

Disclaimer & Data Validity:

The information provided in this document is for Research Use Only (RUO) and is strictly not intended for diagnostic or therapeutic procedures. While BenchChem strives to provide accurate protocols, we make no warranties, express or implied, regarding the fitness of this product for every specific experimental setup.

Technical Support: The protocols provided are for reference purposes. Unsure if this reagent suits your experiment? [[Contact our Ph.D. Support Team for a compatibility check](#)]

Need Industrial/Bulk Grade? [Request Custom Synthesis Quote](#)

BenchChem

Our mission is to be the trusted global source of essential and advanced chemicals, empowering scientists and researchers to drive progress in science and industry.

Contact

Address: 3281 E Guasti Rd
Ontario, CA 91761, United States
Phone: (601) 213-4426
Email: info@benchchem.com