

Technical Support Center: Ensuring Reproducibility in GPR39 Research Studies

Author: BenchChem Technical Support Team. **Date:** December 2025

Compound of Interest

Compound Name: EP39

Cat. No.: B15563916

[Get Quote](#)

Welcome to the technical support center for researchers engaged in the study of GPR39, a G-protein coupled receptor with emerging roles in a variety of physiological processes. This resource provides troubleshooting guidance, frequently asked questions (FAQs), and detailed experimental protocols to facilitate reproducible and reliable experimental outcomes.

Frequently Asked Questions (FAQs)

Q1: What are the known endogenous and synthetic ligands for GPR39, and what are the challenges associated with them?

A1: The primary endogenous ligand for GPR39 is considered to be the zinc ion (Zn²⁺).^{[1][2]} Early reports suggesting obestatin as a ligand have not been consistently reproduced.^{[1][2][3]} A commonly used synthetic agonist is TC-G 1008.

Challenges include:

- Zinc as a ligand: Ensuring accurate and consistent free zinc concentrations in experimental buffers is critical and can be challenging due to chelation by media components.
- TC-G 1008 specificity: While potent, studies have suggested that TC-G 1008 may have off-target effects, necessitating careful validation of its selectivity in your experimental system.

Q2: What are the different splice variants of GPR39 and how do they affect signaling?

A2: Two main splice variants of GPR39 have been identified: the full-length GPR39-1a and a truncated GPR39-1b. GPR39-1b lacks the last two transmembrane domains and the C-terminal tail. Notably, GPR39-1b has been reported to be unresponsive to zinc in calcium mobilization assays, suggesting it may not be a functional zinc receptor. It is crucial to identify which splice variant is expressed in your model system, as this will impact the expected signaling outcomes.

Q3: Does GPR39 exhibit constitutive activity, and how can this impact experimental results?

A3: Yes, GPR39 is known to have a relatively high level of ligand-independent constitutive activity, particularly through the Gαq and Gα12/13 pathways. This constitutive activity can vary between different vertebrate species and may be influenced by the expression level of the receptor. High constitutive activity can lead to a reduced assay window (signal-to-background ratio) and may mask the effects of weak agonists.

Q4: Which signaling pathways are activated by GPR39?

A4: GPR39 is known to couple to multiple G-protein signaling pathways, including:

- Gαq: Leading to the activation of phospholipase C (PLC) and subsequent mobilization of intracellular calcium.
- Gαs: Resulting in the stimulation of adenylyl cyclase and an increase in intracellular cyclic AMP (cAMP).
- Gα12/13: Activating the RhoA signaling pathway.

The specific pathway activated can be influenced by the ligand and the cellular context.

Troubleshooting Guides

Issue 1: Low or No Response to Zinc Stimulation in GPR39-expressing Cells

Possible Cause	Troubleshooting Step
Low Receptor Expression	- Confirm GPR39 expression levels via qPCR or Western blot.- Use a positive control cell line with known high expression.- Optimize transfection or lentiviral transduction efficiency.
Zinc Chelation	- Use a buffered zinc solution to control the free zinc concentration.- Minimize the use of media components known to chelate zinc (e.g., certain amino acids, phosphate).- Perform experiments in a simple saline buffer (e.g., HBSS).
Incorrect GPR39 Splice Variant	- Verify the expression of the full-length, zinc-responsive GPR39-1a variant.
Cell Health	- Ensure cells are healthy and within an optimal passage number.- Check for mycoplasma contamination.
Assay Conditions	- Optimize the stimulation time and temperature.- Ensure the pH of the assay buffer is stable.

Issue 2: High Background Signal in Functional Assays

Possible Cause	Troubleshooting Step
High Constitutive Activity	- Reduce the expression level of GPR39 by using a lower amount of plasmid for transfection or a lower multiplicity of infection (MOI) for lentiviral transduction.- Consider using a cell line with lower endogenous GPR39 expression.
Assay Reagent Issues	- Check for autofluorescence of compounds or assay reagents.- Ensure proper mixing and incubation times for assay reagents.
Instrument Settings	- Optimize the gain and other settings on the plate reader to maximize the signal-to-background ratio.

Issue 3: Inconsistent Results in Calcium Mobilization Assays

Possible Cause	Troubleshooting Step
Uneven Dye Loading	- Ensure a uniform cell monolayer.- Optimize the concentration of the calcium-sensitive dye and the loading time.- Use a "no-wash" dye kit to simplify the protocol and reduce variability.
Photobleaching or Phototoxicity	- Minimize the exposure of the dye-loaded cells to light.- Reduce the intensity and duration of the excitation light during measurement.
Cell Clumping	- Ensure a single-cell suspension before seeding.- Use cell-repellent plates if clumping is a persistent issue.
Inconsistent Agonist Addition	- Use an automated liquid handler for precise and simultaneous addition of the agonist to all wells.

Issue 4: Poor Reproducibility in cAMP Assays

Possible Cause	Troubleshooting Step
Phosphodiesterase (PDE) Activity	- Include a PDE inhibitor (e.g., IBMX) in the assay buffer to prevent the degradation of cAMP.
Low Signal Window	- Optimize the concentration of forskolin (if used to stimulate adenylyl cyclase in antagonist mode).- Increase the cell number per well.
Cell Lysis and Reagent Stability	- Ensure complete cell lysis to release all intracellular cAMP.- Prepare fresh assay reagents and standards for each experiment.
Standard Curve Issues	- Prepare a fresh and accurate cAMP standard curve for every experiment.- Ensure the unknown samples fall within the linear range of the standard curve.

Experimental Protocols

Protocol 1: Transient Transfection of HEK293T Cells with a GPR39 Expression Plasmid

- **Cell Seeding:** Seed HEK293T cells in a 96-well plate at a density of 4×10^4 cells/well in 100 μ L of DMEM supplemented with 10% FBS. Incubate overnight at 37°C and 5% CO₂.
- **Transfection Complex Preparation:** For each well, dilute 100 ng of GPR39 expression plasmid and 0.3 μ L of a suitable transfection reagent in 10 μ L of serum-free DMEM. Incubate at room temperature for 20 minutes.
- **Transfection:** Add the transfection complex to the cells.
- **Incubation:** Incubate the cells for 24-48 hours before performing functional assays.

Protocol 2: Calcium Mobilization Assay

- **Cell Preparation:** Seed GPR39-expressing cells in a black, clear-bottom 96-well plate and grow to confluence.

- **Dye Loading:** Remove the culture medium and add 100 μL of a calcium-sensitive dye loading buffer (e.g., Fluo-4 AM) containing probenecid. Incubate at 37°C for 1 hour.
- **Baseline Reading:** Place the plate in a fluorescence plate reader and measure the baseline fluorescence for 10-20 seconds.
- **Agonist Addition:** Add 20 μL of a 6X concentrated solution of the agonist (e.g., ZnCl_2) to each well.
- **Signal Measurement:** Immediately measure the fluorescence intensity kinetically for 2-3 minutes.

Protocol 3: cAMP Measurement Assay (HTRF)

- **Cell Stimulation:** In a 384-well plate, add 5 μL of GPR39-expressing cells, 5 μL of antagonist (if applicable), and 5 μL of agonist (e.g., TC-G 1008). Incubate at room temperature for 30 minutes.
- **Lysis and Detection:** Add 5 μL of HTRF cAMP-d2 detection reagent and 5 μL of HTRF anti-cAMP-cryptate detection reagent.
- **Incubation:** Incubate at room temperature for 1 hour.
- **Data Acquisition:** Read the plate on an HTRF-compatible plate reader.

Quantitative Data Summary

Parameter	Typical Range	Reference
Zinc (ZnCl_2) EC50 for GPR39	7.3 - 22 μM	
TC-G 1008 EC50 for GPR39	0.4 - 0.8 nM	
HEK293T Transfection Seeding Density (96-well)	2-5 x 10 ⁴ cells/well	General Knowledge
Calcium Assay Dye Loading Time	30-60 minutes	
cAMP Assay Stimulation Time	15-60 minutes	

Visualizations

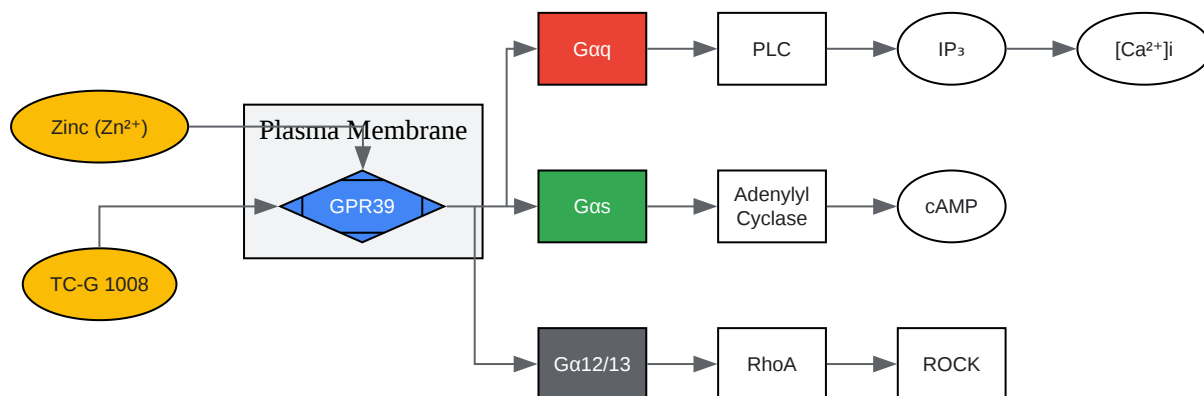

[Click to download full resolution via product page](#)

Caption: GPR39 Signaling Pathways.

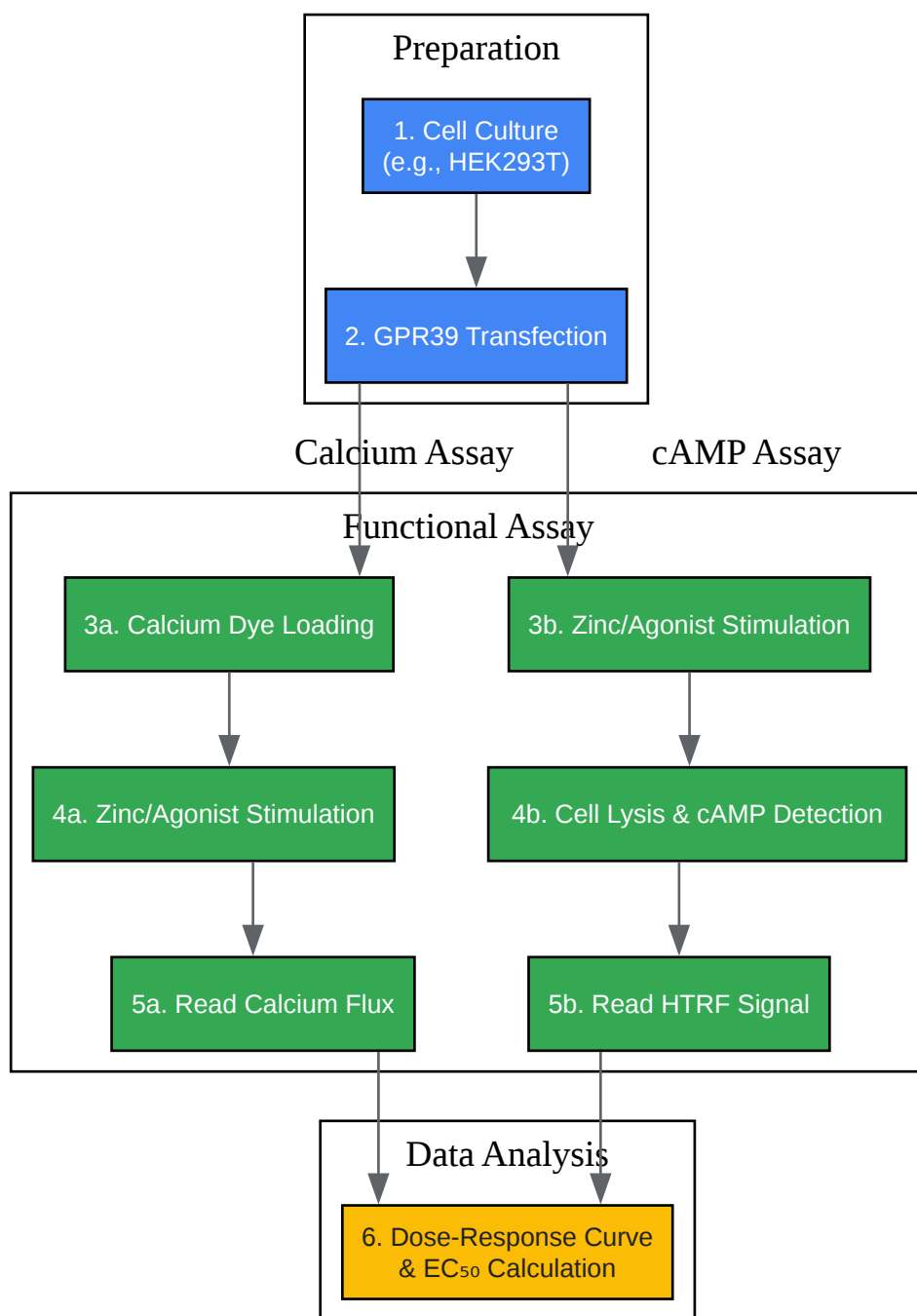

[Click to download full resolution via product page](#)

Caption: GPR39 Experimental Workflow.

Need Custom Synthesis?

BenchChem offers custom synthesis for rare earth carbides and specific isotopic labeling.

Email: info@benchchem.com or [Request Quote Online](#).

References

- 1. academic.oup.com [academic.oup.com]
- 2. GPR39: a Zn²⁺-activated G protein-coupled receptor that regulates pancreatic, gastrointestinal and neuronal functions - PMC [pmc.ncbi.nlm.nih.gov]
- 3. Role of GPR39 in Neurovascular Homeostasis and Disease - PMC [pmc.ncbi.nlm.nih.gov]
- To cite this document: BenchChem. [Technical Support Center: Ensuring Reproducibility in GPR39 Research Studies]. BenchChem, [2025]. [Online PDF]. Available at: [https://www.benchchem.com/product/b15563916#ensuring-reproducibility-in-ep39-research-studies]

Disclaimer & Data Validity:

The information provided in this document is for Research Use Only (RUO) and is strictly not intended for diagnostic or therapeutic procedures. While BenchChem strives to provide accurate protocols, we make no warranties, express or implied, regarding the fitness of this product for every specific experimental setup.

Technical Support: The protocols provided are for reference purposes. Unsure if this reagent suits your experiment? [[Contact our Ph.D. Support Team for a compatibility check](#)]

Need Industrial/Bulk Grade? [Request Custom Synthesis Quote](#)

BenchChem

Our mission is to be the trusted global source of essential and advanced chemicals, empowering scientists and researchers to drive progress in science and industry.

Contact

Address: 3281 E Guasti Rd

Ontario, CA 91761, United States

Phone: (601) 213-4426

Email: info@benchchem.com