

Technical Support Center: Enhancing Fluorescent Probe Sensitivity for Geranylgeranylated Proteins

Author: BenchChem Technical Support Team. **Date:** December 2025

Compound of Interest

Compound Name: Geranylgeranyl pyrophosphate

Cat. No.: B1195527

[Get Quote](#)

Welcome to the technical support center for researchers, scientists, and drug development professionals working with fluorescent probes to study geranylgeranylated proteins. This resource provides troubleshooting guidance, frequently asked questions (FAQs), detailed experimental protocols, and quantitative data to help you optimize your experiments and achieve high-quality, reproducible results.

Troubleshooting Guide

This guide addresses common issues encountered during the labeling and imaging of geranylgeranylated proteins with fluorescent probes.

Problem	Potential Cause	Recommended Solution
Low or No Fluorescent Signal	Inefficient probe incorporation: The fluorescent geranylgeranyl pyrophosphate (GGPP) analog may be a poor substrate for geranylgeranyltransferase (GGTase).	<ul style="list-style-type: none"> - Increase the concentration of the fluorescent probe. - Increase the incubation time to allow for more efficient enzymatic incorporation. - If possible, use a cell line with higher GGTase activity. - Consider using a different fluorescent GGPP analog with better substrate efficiency.^[1] - For in vitro assays, ensure the purity and activity of your recombinant GGTase.
Low protein expression: The target geranylgeranylated protein is not abundant enough.	<ul style="list-style-type: none"> - If using transient transfection, optimize transfection efficiency. - Consider creating a stable cell line expressing the protein of interest. - Use a stronger promoter to drive protein expression. 	
Photobleaching: The fluorophore is being destroyed by the excitation light.	<ul style="list-style-type: none"> - Reduce the intensity and/or duration of the excitation light. ^[2] - Use an anti-fade mounting medium for fixed cells. - Choose a more photostable fluorescent probe if available. - Optimize image acquisition settings (e.g., increase camera sensitivity, use a more sensitive detector). 	
Incorrect filter sets: The excitation and emission filters on the microscope are not optimal for the fluorophore.	<ul style="list-style-type: none"> - Check the excitation and emission spectra of your fluorescent probe and ensure 	

	you are using the correct filter cubes.	
High Background Fluorescence	Non-specific binding of the probe: The fluorescent probe is binding to other cellular components.	<ul style="list-style-type: none"> - Decrease the concentration of the fluorescent probe. - Increase the number and duration of wash steps after probe incubation. - Include a blocking step (e.g., with BSA) before adding the probe in fixed cell experiments.[3]
Autofluorescence: The cells or medium have endogenous fluorescence.	<ul style="list-style-type: none"> - Use a culture medium with low background fluorescence (e.g., phenol red-free medium). - Use cell lines with lower intrinsic autofluorescence if possible. - Acquire a control image of unlabeled cells to determine the level of autofluorescence and use it for background subtraction. - Consider using a fluorescent probe in the red or far-red spectrum to minimize interference from cellular autofluorescence, which is typically stronger in the green and yellow channels.[3] 	
Probe aggregation: The fluorescent probe is forming aggregates that are non-specifically associating with cells.	<ul style="list-style-type: none"> - Prepare fresh probe solutions and filter them before use. - Test different solvents for dissolving the probe to improve solubility. 	
Signal Not Localized as Expected	Probe mis-targeting: The fluorescent GGPP analog may be incorporated into proteins	<ul style="list-style-type: none"> - Validate the localization of your fluorescently labeled protein by co-staining with a

that are not the primary target, or the fluorescent tag may alter the natural localization of the protein.

known marker for the expected organelle or cellular compartment. - Perform knockdown or knockout experiments of your target protein to confirm that the fluorescent signal is dependent on its expression. - The size and chemical nature of the fluorophore can sometimes influence protein trafficking. If possible, test probes with different fluorophores.^[1]

Overexpression artifacts: High levels of protein expression can lead to mislocalization.

- Titrate the amount of plasmid used for transfection to achieve lower, more physiological expression levels. - Use an inducible expression system to control the level of protein expression.

Signal is Diffuse and Lacks Sharp Features

Poor signal-to-noise ratio (SNR): The fluorescent signal is weak relative to the background noise.

- Optimize all aspects of the experiment to increase signal and decrease background (see sections above). - Use a higher numerical aperture (NA) objective to collect more light.^[2] - Employ image processing techniques such as deconvolution to improve image clarity.

Out-of-focus light: For thick specimens, fluorescence from above and below the focal plane can blur the image.

- Use a confocal or other sectioning microscope to reject out-of-focus light.

Frequently Asked Questions (FAQs)

Q1: Which fluorescent GGPP analog should I choose for my experiments?

A1: The choice of fluorescent GGPP analog depends on several factors, including the specific application, the instrumentation available, and the biological system being studied. Analogs with smaller fluorophores, such as NBD (nitrobenzoxadiazole), are often better substrates for prenyltransferases.^[1] However, NBD has a relatively low quantum yield and is prone to photobleaching. Probes with brighter and more photostable dyes may provide better sensitivity for imaging, but their larger size could interfere with enzymatic incorporation or protein function. It is often necessary to empirically test a few different probes to find the one that works best for your specific experiment.

Q2: How can I be sure that the fluorescent signal I'm seeing is from the geranylgeranylation of my protein of interest?

A2: Several control experiments are essential to validate the specificity of your fluorescent signal:

- **Inhibition of Geranylgeranylation:** Treat cells with a specific inhibitor of GGTase I or RabGGTase. A significant reduction in the fluorescent signal would indicate that it is dependent on geranylgeranylation.
- **Competition with Natural Substrate:** Co-incubate the cells with the fluorescent probe and an excess of non-fluorescent GGPP. The natural substrate should compete with the fluorescent analog for the enzyme, leading to a decrease in the fluorescent signal.
- **Mutation of the Prenylation Motif:** Mutate the C-terminal CAAX box or CC/CXC motif of your protein of interest that signals for geranylgeranylation. The mutant protein should not be labeled with the fluorescent probe.
- **Immunofluorescence Co-localization:** Co-stain the cells with an antibody specific to your protein of interest and a secondary antibody with a different colored fluorophore. Co-localization of the two signals provides strong evidence that the fluorescent probe is labeling your target protein.

Q3: Can I use these fluorescent probes for in vivo studies in animal models?

A3: While challenging, it is possible. The delivery and bioavailability of the fluorescent probe to the target tissue in a living animal are significant hurdles. The probe must be able to cross cell membranes and reach the intracellular compartment where geranylgeranylation occurs.

Additionally, the signal from the probe needs to be detectable through the tissue. This often requires probes that fluoresce in the near-infrared (NIR) window, where tissue penetration of light is maximal.

Q4: What is a typical concentration range for using fluorescent GGPP analogs in cell culture?

A4: The optimal concentration of a fluorescent GGPP analog needs to be determined empirically for each cell type and experimental setup. A starting point is typically in the low micromolar range (e.g., 1-10 μM).^[4] It is a balance between achieving sufficient signal and minimizing potential cytotoxicity or off-target effects from the probe.

Quantitative Data

The following tables summarize key quantitative data for commonly used fluorescent probes and relevant cellular parameters.

Table 1: Properties of a Common Fluorescent GGPP Analog

Probe	Fluorophore	Excitation Max (nm)	Emission Max (nm)	Reported Fluorescence Enhancement	Reference
NBD-GGPP	NBD	~465	~535	~2-fold upon enzymatic transfer to protein	[5]

Table 2: Intracellular Isoprenoid Concentrations

Isoprenoid	Cell Type	Concentration (pmol/106 cells)	Reference
Farnesyl pyrophosphate (FPP)	NIH3T3	0.125 ± 0.010	[6][7]
Geranylgeranyl pyrophosphate (GGPP)	NIH3T3	0.145 ± 0.008	[6][7]

Experimental Protocols

Protocol 1: In Vitro Geranylgeranylation Assay with a Fluorescent GGPP Analog

This protocol describes a method to measure the activity of a geranylgeranyltransferase (GGTase) in vitro using a fluorescent GGPP analog.

Materials:

- Purified recombinant GGTase (e.g., GGTase-I or RabGGTase)
- Purified substrate protein with a C-terminal geranylgeranylation motif (e.g., a Rho or Rab GTPase)
- Fluorescent GGPP analog (e.g., NBD-GGPP)
- Assay buffer (e.g., 50 mM HEPES, pH 7.5, 50 mM NaCl, 10 mM MgCl₂, 5 mM DTT)
- SDS-PAGE gels and running buffer
- Fluorescence gel scanner

Procedure:

- Prepare a reaction mixture containing the assay buffer, the substrate protein (e.g., 1-5 μM), and the fluorescent GGPP analog (e.g., 1-10 μM).

- Pre-incubate the reaction mixture at the optimal temperature for the enzyme (e.g., 37°C) for 5 minutes.
- Initiate the reaction by adding the purified GGase to a final concentration of, for example, 100 nM.
- Incubate the reaction at 37°C for a specific time course (e.g., 0, 15, 30, 60 minutes).
- Stop the reaction at each time point by adding an equal volume of 2x SDS-PAGE loading buffer and heating at 95°C for 5 minutes.
- Resolve the proteins by SDS-PAGE.
- Visualize the fluorescently labeled protein using a fluorescence gel scanner with the appropriate excitation and emission settings for the fluorophore.
- Quantify the fluorescence intensity of the protein band at each time point to determine the reaction rate.

Protocol 2: Live-Cell Imaging of Geranylgeranylated Proteins

This protocol outlines a general procedure for labeling and imaging geranylgeranylated proteins in living cells using a cell-permeable fluorescent GGPP analog.

Materials:

- Cultured cells grown on glass-bottom dishes or coverslips
- Cell-permeable fluorescent GGPP analog
- Live-cell imaging medium (e.g., phenol red-free DMEM with serum and supplements)
- Fluorescence microscope equipped with a live-cell incubation chamber (maintaining 37°C and 5% CO₂)

Procedure:

- Seed the cells on glass-bottom dishes or coverslips and allow them to adhere and grow to the desired confluency.
- If expressing a protein of interest, transfect the cells with the corresponding plasmid and allow for protein expression (typically 24-48 hours).
- Remove the culture medium and replace it with fresh, pre-warmed live-cell imaging medium containing the fluorescent GGPP analog at the desired concentration (e.g., 1-10 μM).
- Incubate the cells for a sufficient time to allow for probe uptake and incorporation (e.g., 4-24 hours). This will need to be optimized.
- Gently wash the cells two to three times with pre-warmed live-cell imaging medium to remove excess, unincorporated probe.
- Place the dish on the microscope stage within the incubation chamber.
- Allow the cells to equilibrate for at least 15-30 minutes before imaging.
- Acquire images using the appropriate fluorescence filter set and minimal excitation light to reduce phototoxicity. Time-lapse imaging can be performed to track the dynamics of the labeled proteins.

Signaling Pathways and Experimental Workflows

Rho GTPase Activation and Geranylgeranylation

The function of Rho family GTPases, such as RhoA, Rac1, and Cdc42, is critically dependent on their post-translational geranylgeranylation. This lipid modification is essential for their localization to cellular membranes, where they can be activated by Guanine Nucleotide Exchange Factors (GEFs) and interact with downstream effectors to regulate the actin cytoskeleton, cell adhesion, and cell migration.[\[1\]](#)[\[8\]](#)[\[9\]](#)

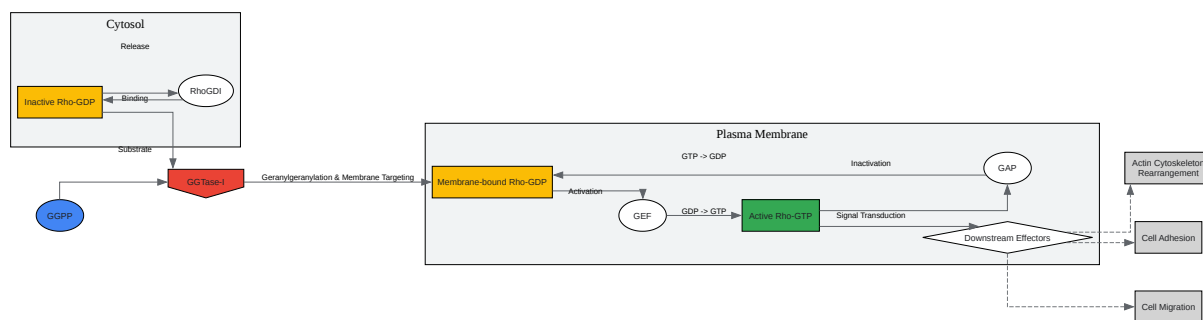

[Click to download full resolution via product page](#)

Rho GTPase activation cycle and the role of geranylgeranylation.

Rab GTPase Membrane Trafficking Cycle

Rab GTPases are master regulators of vesicular transport, and their function is also dependent on geranylgeranylation. This modification, catalyzed by RabGGTase, allows Rab proteins to associate with the membranes of specific organelles and transport vesicles, thereby controlling their budding, transport, and fusion.^{[8][9][10]}

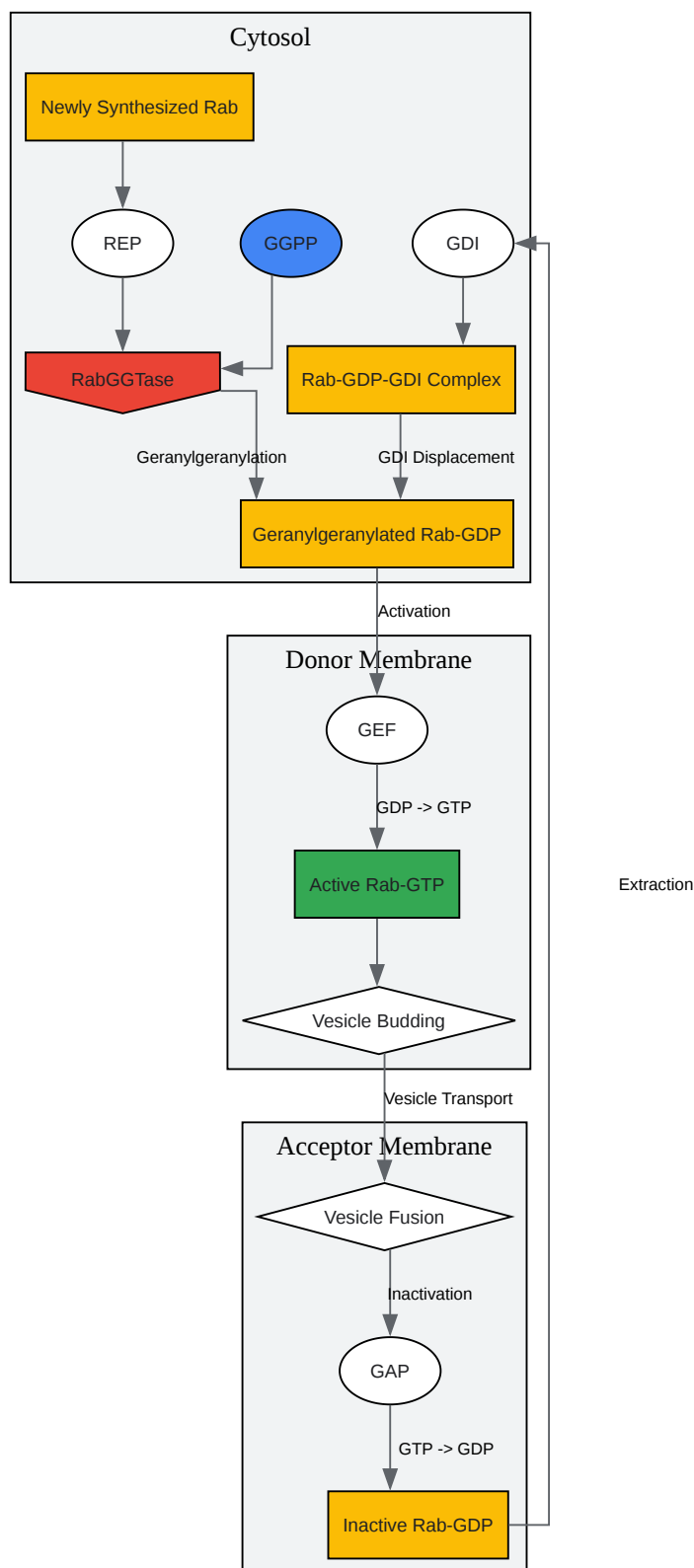

[Click to download full resolution via product page](#)

The Rab GTPase cycle in vesicular transport.

Experimental Workflow for Identifying Geranylgeranylated Proteins

This workflow outlines the steps for identifying geranylgeranylated proteins in a cellular lysate using a fluorescent GGPP analog with a clickable handle, followed by enrichment and mass spectrometry.

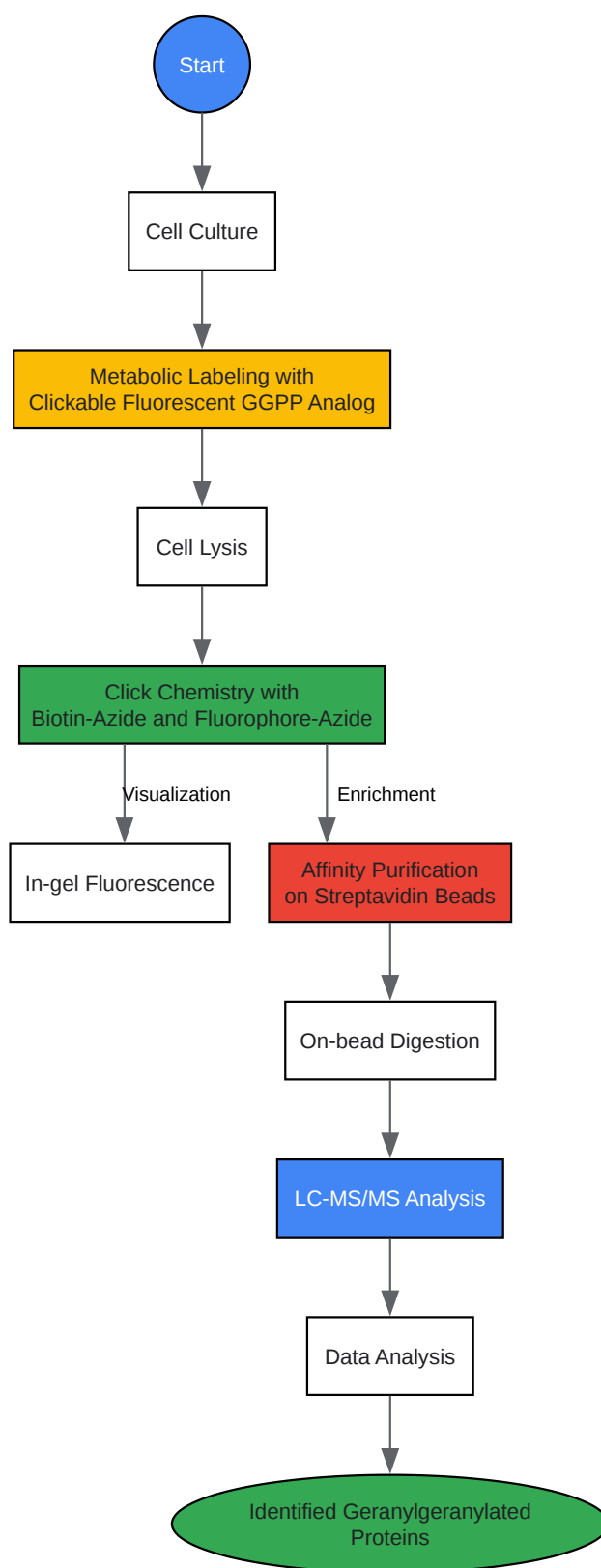

[Click to download full resolution via product page](#)

Workflow for proteomic identification of geranylgeranylated proteins.

Need Custom Synthesis?

BenchChem offers custom synthesis for rare earth carbides and specific isotopic labeling.

Email: info@benchchem.com or [Request Quote Online](#).

References

- 1. Synthetic Isoprenoid Analogues for the Study of Prenylated Proteins: Fluorescent Imaging and Proteomic Applications - PMC [[pmc.ncbi.nlm.nih.gov](https://pubmed.ncbi.nlm.nih.gov/)]
- 2. youtube.com [[youtube.com](https://www.youtube.com/)]
- 3. Troubleshooting in Fluorescent Staining - Creative Bioarray | Creative Bioarray [[creative-bioarray.com](https://www.creative-bioarray.com/)]
- 4. Dual Chemical Probes Enable Quantitative System-Wide Analysis of Protein Prenylation and Prenylation Dynamics - PMC [[pmc.ncbi.nlm.nih.gov](https://pubmed.ncbi.nlm.nih.gov/)]
- 5. researchgate.net [[researchgate.net](https://www.researchgate.net/)]
- 6. researchgate.net [[researchgate.net](https://www.researchgate.net/)]
- 7. diagrammingai.com [[diagrammingai.com](https://www.diagrammingai.com/)]
- 8. Role of Rab GTPases in Membrane Traffic and Cell Physiology - PMC [[pmc.ncbi.nlm.nih.gov](https://pubmed.ncbi.nlm.nih.gov/)]
- 9. researchgate.net [[researchgate.net](https://www.researchgate.net/)]
- 10. Membrane Targeting of Rab GTPases Is Influenced by the Prenylation Motif - PMC [[pmc.ncbi.nlm.nih.gov](https://pubmed.ncbi.nlm.nih.gov/)]
- To cite this document: BenchChem. [Technical Support Center: Enhancing Fluorescent Probe Sensitivity for Geranylgeranylated Proteins]. BenchChem, [2025]. [Online PDF]. Available at: [<https://www.benchchem.com/product/b1195527#enhancing-the-sensitivity-of-fluorescent-probes-for-geranylgeranylated-proteins>]

Disclaimer & Data Validity:

The information provided in this document is for Research Use Only (RUO) and is strictly not intended for diagnostic or therapeutic procedures. While BenchChem strives to provide accurate protocols, we make no warranties, express or implied, regarding the fitness of this product for every specific experimental setup.

Technical Support: The protocols provided are for reference purposes. Unsure if this reagent suits your experiment? [[Contact our Ph.D. Support Team for a compatibility check](#)]

Need Industrial/Bulk Grade? [Request Custom Synthesis Quote](#)

BenchChem

Our mission is to be the trusted global source of essential and advanced chemicals, empowering scientists and researchers to drive progress in science and industry.

Contact

Address: 3281 E Guasti Rd

Ontario, CA 91761, United States

Phone: (601) 213-4426

Email: info@benchchem.com