

Technical Support Center: Enhancing E4177 Bioavailability in Rats

Author: BenchChem Technical Support Team. **Date:** December 2025

Compound of Interest

Compound Name: E4177

Cat. No.: B1671017

[Get Quote](#)

This technical support center provides troubleshooting guides and frequently asked questions (FAQs) to assist researchers and drug development professionals in improving the oral bioavailability of the AT1R antagonist, **E4177**, in rat models.

Frequently Asked Questions (FAQs)

Q1: What are the initial steps to consider when encountering low oral bioavailability with **E4177** in rats?

A1: Low oral bioavailability is a common challenge for poorly soluble compounds. The initial steps should focus on characterizing the physicochemical properties of **E4177** and identifying the primary barriers to its absorption. Key factors to investigate include aqueous solubility, gastrointestinal permeability, and first-pass metabolism.^[1] A systematic approach to pre-formulation studies is crucial for developing an effective formulation strategy.^{[2][3]}

Q2: What are the most common formulation strategies to improve the bioavailability of poorly soluble drugs like **E4177**?

A2: Several formulation strategies can be employed to enhance the oral bioavailability of compounds with low aqueous solubility.^[1] These can be broadly categorized as:

- **Particle Size Reduction:** Techniques like micronization and nanosizing increase the surface area of the drug, which can improve the dissolution rate.^[4]

- Solid Dispersions: Dispersing **E4177** in a hydrophilic polymer matrix can create an amorphous solid dispersion, enhancing its dissolution.[4][5]
- Lipid-Based Formulations: Self-emulsifying drug delivery systems (SEDDS), microemulsions, and solid lipid nanoparticles can improve the solubility of lipophilic drugs and may facilitate lymphatic uptake, bypassing first-pass metabolism.[6]
- Co-solvents and Surfactants: The use of co-solvents or surfactants can enhance drug solubility.[1]
- Complexation: Utilizing cyclodextrins to form inclusion complexes can increase the aqueous solubility of the drug.[6]

Q3: How do I select the appropriate animal model for **E4177** bioavailability studies?

A3: Healthy male Sprague-Dawley rats (270–300 g) are a commonly used and appropriate model for initial oral bioavailability studies.[4] It is important to house the animals in controlled conditions (e.g., $22 \pm 2^\circ\text{C}$, 50-60% humidity) with free access to food and water.[4] For the experiment, rats should be fasted overnight.[4]

Q4: Are there any known metabolic pathways for **E4177** in rats that could affect its bioavailability?

A4: While specific metabolic pathways for **E4177** are not extensively documented in publicly available literature, it is crucial to consider potential metabolism by the liver and intestinal flora. For instance, some compounds undergo extensive pre-absorption degradation by intestinal contents, which significantly lowers bioavailability.[7] In vitro studies using rat liver microsomes or S9 fractions can provide initial insights into potential metabolic instability.[8][9]

Troubleshooting Guides

Issue 1: Inconsistent results in **E4177** in vitro dissolution testing.

Potential Cause & Solution:

Inconsistent dissolution results can arise from several factors.[4]

- **Apparatus Calibration:** Ensure your dissolution apparatus is properly calibrated and that test conditions such as temperature and rotation speed are stable and uniform.[4]
- **Dissolution Medium:** The choice of dissolution medium is critical. For a poorly soluble compound like **E4177**, the medium should be appropriate for the drug's properties. The addition of surfactants may be necessary to achieve sink conditions.[4]
- **Drug Distribution:** Inhomogeneity in the drug distribution within the dosage form can lead to variable dissolution.[4]

Issue 2: Good in vitro dissolution of an **E4177** formulation, but still low oral bioavailability in rats.

Potential Cause & Solution:

This scenario suggests that factors beyond dissolution are limiting the bioavailability of **E4177**.

- **First-Pass Metabolism:** **E4177** may be undergoing extensive first-pass metabolism in the liver. To investigate this, conduct in vitro metabolism studies using rat liver microsomes.
- **Poor Permeability:** The drug may have poor permeability across the intestinal wall. In situ intestinal perfusion studies in rats can be performed to assess this.
- **Efflux Transporters:** **E4177** might be a substrate for efflux transporters like P-glycoprotein (P-gp), which actively pump the drug out of intestinal cells. Co-administration with a P-gp inhibitor can help to investigate this possibility.

Experimental Protocols

Protocol 1: Preparation of a Lipid-Based Formulation (SEDDS) for **E4177**

- **Excipient Screening:** Screen various oils, surfactants, and co-surfactants for their ability to dissolve **E4177**.
- **Ternary Phase Diagram Construction:** Construct ternary phase diagrams to identify the self-emulsifying region for the selected excipients.

- **Formulation Preparation:** Prepare the SEDDS formulation by mixing the selected oil, surfactant, and co-surfactant in the determined ratios. Add **E4177** to the mixture and stir until it is completely dissolved.
- **Characterization:** Characterize the formulation for self-emulsification time, droplet size, and drug content.

Protocol 2: In Vivo Pharmacokinetic Study in Rats

- **Animal Model:** Use healthy male Sprague-Dawley rats (270–300 g), fasted overnight before the experiment.[4]
- **Dosing:**
 - **Oral (PO) Administration:** Prepare the desired oral formulation of **E4177**. Administer the formulation to the rats via oral gavage at a specific dose (e.g., 10 mg/kg).[4]
 - **Intravenous (IV) Administration:** For determining absolute bioavailability, administer a solubilized form of **E4177** to a separate group of rats via the tail vein (e.g., 1 mg/kg).[8]
- **Blood Sampling:** Collect blood samples from the jugular vein at predetermined time points (e.g., 0.083, 0.25, 0.5, 1, 2, 4, 8, and 24 hours) post-dosing.[8]
- **Sample Analysis:** Determine the concentration of **E4177** in plasma samples using a validated analytical method, such as HPLC with UV or fluorescence detection.[8]
- **Pharmacokinetic Analysis:** Calculate pharmacokinetic parameters (C_{max} , T_{max} , AUC) using appropriate software. Calculate the oral bioavailability (F%) using the formula: $F\% = (AUC_{oral} / AUC_{iv}) \times (Dose_{iv} / Dose_{oral}) \times 100$.[4]

Data Presentation

Table 1: Hypothetical Pharmacokinetic Parameters of **E4177** in Different Formulations in Rats

Formulation	Dose (mg/kg)	Route	Cmax (ng/mL)	Tmax (h)	AUC (ng·h/mL)	Bioavailability (F%)
Aqueous Suspension	30	PO	50 ± 12	2.0	250 ± 60	< 1%
Micronized Suspension	30	PO	150 ± 35	1.5	900 ± 210	3%
Solid Dispersion	30	PO	450 ± 98	1.0	3750 ± 850	12.5%
SEDDS	30	PO	850 ± 150	0.5	7500 ± 1300	25%
IV Solution	1	IV	1000 ± 200	0.083	3000 ± 550	100%

Data are presented as mean ± standard deviation (n=6 rats per group).[\[4\]](#)

Visualizations

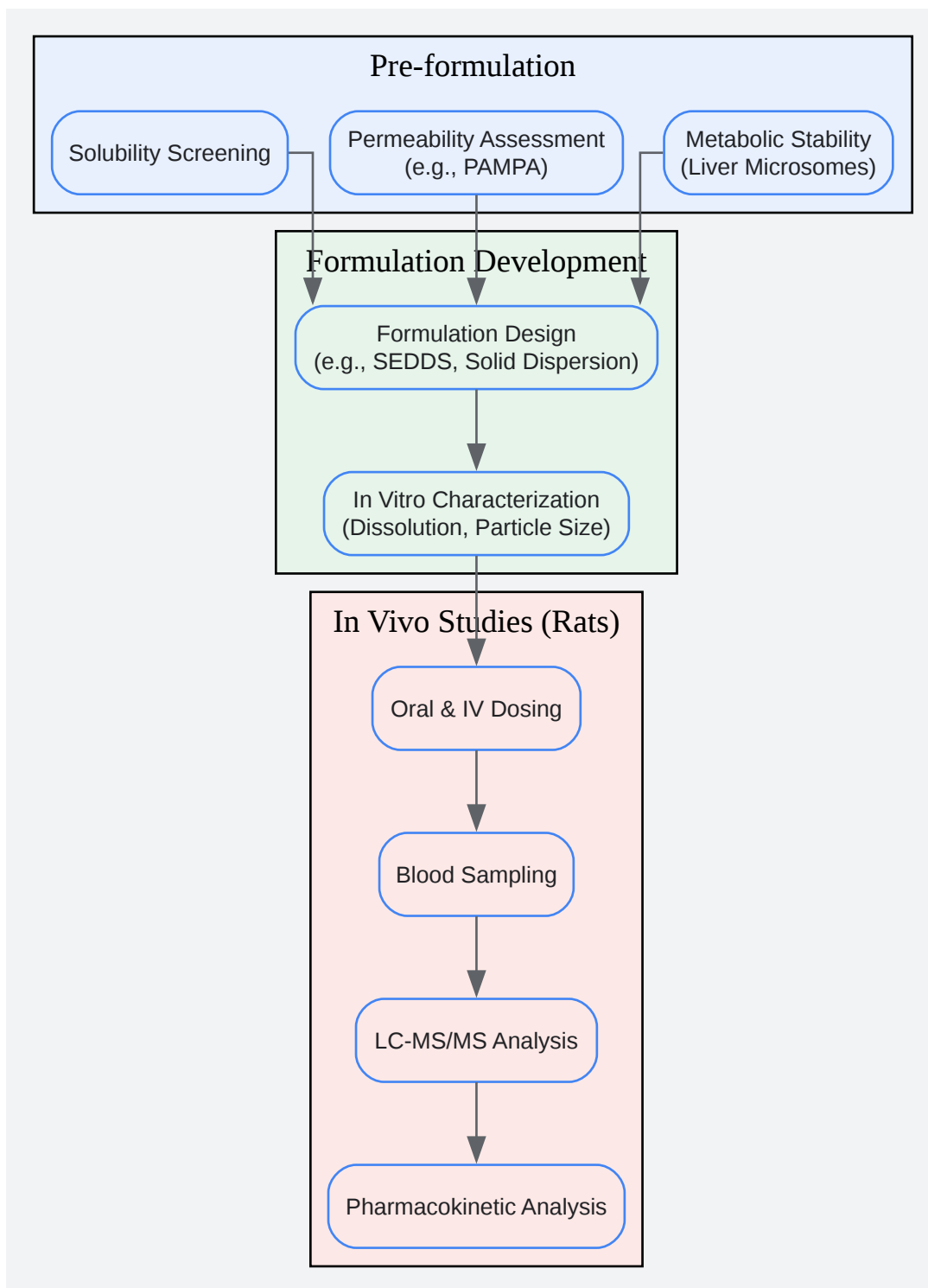

[Click to download full resolution via product page](#)

Caption: Workflow for improving **E4177** bioavailability.

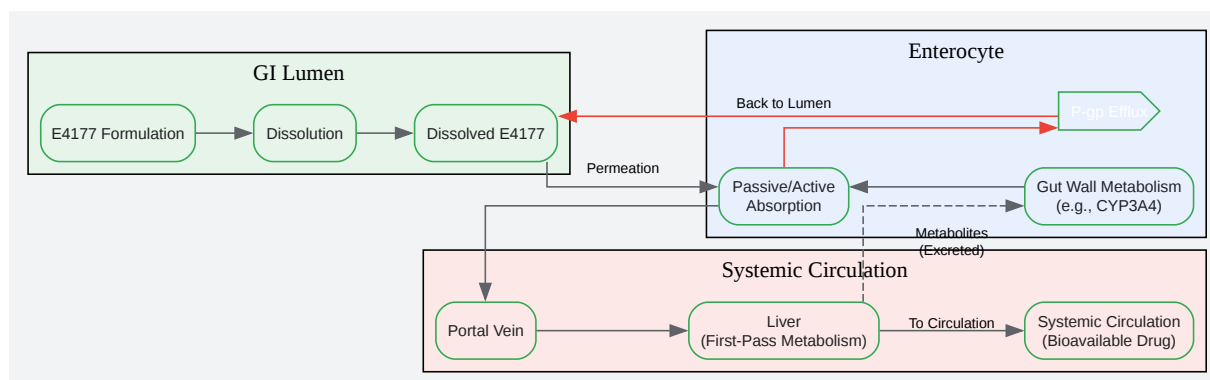

[Click to download full resolution via product page](#)

Caption: Factors affecting oral drug absorption.

Need Custom Synthesis?

BenchChem offers custom synthesis for rare earth carbides and specific isotopic labeling.

Email: info@benchchem.com or [Request Quote Online](#).

References

- 1. researchgate.net [researchgate.net]
- 2. Formulations strategies for biopharmaceuticals--ensuring success to market - PubMed [pubmed.ncbi.nlm.nih.gov]
- 3. Preclinical Formulations: Insight, Strategies, and Practical Considerations - PMC [pmc.ncbi.nlm.nih.gov]
- 4. benchchem.com [benchchem.com]
- 5. Development of a Solid Dispersion System for Improving the Oral Bioavailability of Resveratrol in Rats - PubMed [pubmed.ncbi.nlm.nih.gov]
- 6. What are the methods used for enhancement of bioavailability? [synapse.patsnap.com]

- 7. Pharmacokinetics, Bioavailability, Excretion and Metabolism Studies of Akebia Saponin D in Rats: Causes of the Ultra-Low Oral Bioavailability and Metabolic Pathway - PMC [pmc.ncbi.nlm.nih.gov]
- 8. Improved oral bioavailability in rats of SR13668, a novel anti-cancer agent - PMC [pmc.ncbi.nlm.nih.gov]
- 9. Metabolism of alcohol ethoxylates (AEs) in rat, hamster, and human hepatocytes and liver S9: a pilot study for metabolic stability, metabolic pathway, and metabolites identification in vitro and in silico - PubMed [pubmed.ncbi.nlm.nih.gov]
- To cite this document: BenchChem. [Technical Support Center: Enhancing E4177 Bioavailability in Rats]. BenchChem, [2025]. [Online PDF]. Available at: [https://www.benchchem.com/product/b1671017#how-to-improve-e4177-bioavailability-in-rats]

Disclaimer & Data Validity:

The information provided in this document is for Research Use Only (RUO) and is strictly not intended for diagnostic or therapeutic procedures. While BenchChem strives to provide accurate protocols, we make no warranties, express or implied, regarding the fitness of this product for every specific experimental setup.

Technical Support: The protocols provided are for reference purposes. Unsure if this reagent suits your experiment? [[Contact our Ph.D. Support Team for a compatibility check](#)]

Need Industrial/Bulk Grade? [Request Custom Synthesis Quote](#)

BenchChem

Our mission is to be the trusted global source of essential and advanced chemicals, empowering scientists and researchers to drive progress in science and industry.

Contact

Address: 3281 E Guasti Rd
Ontario, CA 91761, United States
Phone: (601) 213-4426
Email: info@benchchem.com