

Technical Support Center: Enhancing Brain Delivery of Jujuboside A

Author: BenchChem Technical Support Team. **Date:** December 2025

Compound of Interest

Compound Name: Jujuboside-A

Cat. No.: B1673115

[Get Quote](#)

This technical support center provides researchers, scientists, and drug development professionals with troubleshooting guides and frequently asked questions (FAQs) to overcome the challenges associated with the poor blood-brain barrier (BBB) penetration of Jujuboside A (JuA).

Frequently Asked Questions (FAQs)

Q1: Why is the blood-brain barrier penetration of Jujuboside A inherently low?

A1: The low BBB penetration of Jujuboside A (JuA) is attributed to several physicochemical and physiological factors:

- **High Molecular Weight:** JuA has a relatively large molecular weight (1207.35 g/mol), which sterically hinders its passive diffusion across the tight junctions of the BBB.[1][2][3]
- **Hydrophilicity:** The presence of multiple sugar moieties in its structure imparts a significant degree of hydrophilicity, which is unfavorable for traversing the lipid-rich endothelial cell membranes of the BBB.
- **Efflux Transporter Substrate:** It is hypothesized that JuA may be a substrate for efflux transporters, such as P-glycoprotein (P-gp), which are highly expressed at the BBB and actively pump xenobiotics back into the bloodstream.[4][5]

Q2: What are the most promising strategies to enhance the delivery of Jujuboside A to the central nervous system (CNS)?

A2: Several advanced drug delivery strategies can be employed to improve the CNS bioavailability of JuA:

- **Nanoparticle-Based Delivery Systems:** Encapsulating JuA in nanoparticles, such as liposomes, solid lipid nanoparticles (SLNs), or polymeric nanoparticles, can mask its unfavorable physicochemical properties and facilitate its transport across the BBB.[6]
- **Intranasal Delivery:** The intranasal route offers a non-invasive method to bypass the BBB and deliver drugs directly to the brain via the olfactory and trigeminal nerve pathways.[7][8]
- **Chemical Modification:** Although more complex, chemical modification of the JuA molecule to increase its lipophilicity could enhance its passive diffusion across the BBB.
- **Inhibition of Efflux Pumps:** Co-administration of JuA with a P-gp inhibitor could increase its brain concentration by preventing its efflux from the endothelial cells of the BBB.[4][5]

Q3: How can I assess the BBB penetration of my Jujuboside A formulation in vitro?

A3: In vitro BBB models are crucial for the initial screening of JuA formulations. A commonly used and reliable method is the Transwell co-culture model. This model typically involves seeding brain endothelial cells on a semi-permeable membrane in the upper chamber and astrocytes in the lower chamber, mimicking the cellular organization of the BBB.[9][10] The integrity of the barrier is assessed by measuring the transendothelial electrical resistance (TEER).[9][10][11][12][13] A high TEER value indicates the formation of tight junctions. The permeability of your JuA formulation can then be quantified by adding it to the apical (blood) side and measuring its concentration in the basolateral (brain) side over time.

Troubleshooting Guides

Guide 1: Low Encapsulation Efficiency of Jujuboside A in Lipid-Based Nanoparticles

Problem: You are experiencing low encapsulation efficiency (<50%) of JuA in your liposome or solid lipid nanoparticle (SLN) formulation.

Possible Cause	Troubleshooting Step
Poor affinity of JuA for the lipid matrix.	Due to its hydrophilic nature, JuA may have limited partitioning into the lipid core. Try using a modified formulation method that facilitates the encapsulation of hydrophilic molecules, such as the reverse-phase evaporation method for liposomes or a double emulsion technique (w/o/w) for SLNs.
High water solubility of JuA.	During the formulation process, JuA may preferentially remain in the aqueous phase rather than being encapsulated. Optimize the pH of the aqueous phase to a point where the solubility of JuA is minimized, thereby promoting its partitioning into the lipid phase.
Suboptimal lipid composition.	The choice of lipids and their ratios can significantly impact drug loading. Experiment with different lipid compositions, including the addition of charged lipids (e.g., DOTAP, DPPG) to potentially improve the encapsulation of the glycosidic JuA through electrostatic interactions.
Saponin-induced membrane disruption.	Saponins like JuA can have surfactant-like properties that may disrupt the integrity of the lipid bilayer during formulation. ^[14] Try reducing the initial concentration of JuA or incorporating cholesterol into the lipid formulation to enhance membrane stability.

Guide 2: Inconsistent Results in In Vitro BBB Permeability Studies

Problem: Your in vitro BBB model shows high variability in TEER values and inconsistent permeability results for your JuA formulation.

Possible Cause	Troubleshooting Step
Incomplete formation of tight junctions.	Ensure that the brain endothelial cells have reached confluency and have been co-cultured with astrocytes for a sufficient period (typically 5-7 days) to allow for the induction and formation of robust tight junctions.[9][10] Monitor TEER daily, and only use Transwells that have achieved a stable and high TEER value for your permeability experiments.
Cytotoxicity of the JuA formulation.	High concentrations of your JuA-loaded nanoparticles may be toxic to the endothelial cells, compromising the integrity of the BBB model. Perform a cell viability assay (e.g., MTT, LDH) to determine the non-toxic concentration range of your formulation on the endothelial cells and use concentrations below this threshold for your permeability studies.
Variability in cell culture conditions.	Inconsistent cell seeding densities, passage numbers, or media composition can lead to variability in the BBB model. Standardize your cell culture protocols meticulously.
Efflux pump activity.	If your JuA formulation is a substrate for efflux pumps, you may observe low apical-to-basolateral transport. To confirm this, perform a bi-directional transport study (apical-to-basolateral and basolateral-to-apical). A higher basolateral-to-apical transport indicates the involvement of efflux pumps. You can also co-administer a known P-gp inhibitor (e.g., verapamil) to see if it increases the apical-to-basolateral transport of your formulation.

Experimental Protocols

Protocol 1: Preparation and Characterization of Jujuboside A-Loaded Solid Lipid Nanoparticles (JuA-SLNs)

This protocol describes a high-shear homogenization and ultrasonication method for preparing JuA-SLNs.

Materials:

- Jujuboside A (JuA)
- Glyceryl monostearate (Lipid)
- Poloxamer 188 (Surfactant)
- Purified water

Procedure:

- Preparation of the Lipid Phase: Melt the glyceryl monostearate at a temperature approximately 5-10°C above its melting point.
- Preparation of the Aqueous Phase: Dissolve the Poloxamer 188 and Jujuboside A in purified water and heat to the same temperature as the lipid phase.
- Emulsification: Add the hot aqueous phase to the melted lipid phase and homogenize using a high-shear homogenizer at 10,000 rpm for 15 minutes to form a coarse oil-in-water emulsion.
- Ultrasonication: Immediately sonicate the coarse emulsion using a probe sonicator for 10 minutes to reduce the particle size and form a nanoemulsion.
- Nanoparticle Formation: Cool the nanoemulsion in an ice bath with gentle stirring to allow the lipid to solidify and form JuA-SLNs.
- Characterization:

- Particle Size and Zeta Potential: Determine using Dynamic Light Scattering (DLS).
- Encapsulation Efficiency (EE%) and Drug Loading (DL%): Separate the unencapsulated JuA from the SLNs by ultracentrifugation. Quantify the amount of JuA in the supernatant and in the total formulation using a validated analytical method (e.g., HPLC).
 - $EE\% = [(Total\ JuA - JuA\ in\ supernatant) / Total\ JuA] \times 100$
 - $DL\% = [(Total\ JuA - JuA\ in\ supernatant) / Total\ lipid\ weight] \times 100$

Hypothetical Characterization Data for JuA-SLNs:

Formulation	Particle Size (nm)	Polydispersity Index (PDI)	Zeta Potential (mV)	Encapsulation Efficiency (%)	Drug Loading (%)
Optimized JuA-SLNs	150 ± 10	0.2 ± 0.05	-25 ± 5	75 ± 5	5 ± 1

Protocol 2: In Vivo Pharmacokinetic Study of JuA-SLNs in Rats

This protocol outlines a typical in vivo study to assess the brain targeting efficiency of JuA-SLNs.

Animals: Male Sprague-Dawley rats (200-250 g)

Procedure:

- Animal Groups:
 - Group 1: Intravenous (i.v.) injection of free JuA solution.
 - Group 2: Intravenous (i.v.) injection of JuA-SLNs.
- Dosing: Administer the formulations via the tail vein at a JuA dose of 5 mg/kg.

- **Sample Collection:** At predetermined time points (e.g., 0.25, 0.5, 1, 2, 4, 8, 12, 24 hours), collect blood samples via the retro-orbital plexus. Immediately following blood collection, perfuse the rats with saline and harvest the brains.
- **Sample Processing:** Separate plasma from the blood samples. Homogenize the brain tissue.
- **Quantification:** Determine the concentration of JuA in plasma and brain homogenates using a validated LC-MS/MS method.
- **Data Analysis:** Calculate pharmacokinetic parameters such as AUC (Area Under the Curve), Cmax (Maximum Concentration), and Tmax (Time to Maximum Concentration) for both plasma and brain. Calculate the brain-to-plasma concentration ratio and the drug targeting efficiency (DTE).

Hypothetical Pharmacokinetic Data for JuA Formulations:

Formulation	AUC ₀₋₂₄ (ng·h/mL) - Plasma	AUC ₀₋₂₄ (ng·h/g) - Brain	Cmax (ng/mL) - Plasma	Cmax (ng/g) - Brain	Brain/Plasma AUC Ratio
Free JuA	1200 ± 150	60 ± 15	350 ± 50	10 ± 3	0.05
JuA-SLNs	3600 ± 400	450 ± 60	800 ± 100	80 ± 15	0.125

Visualizations

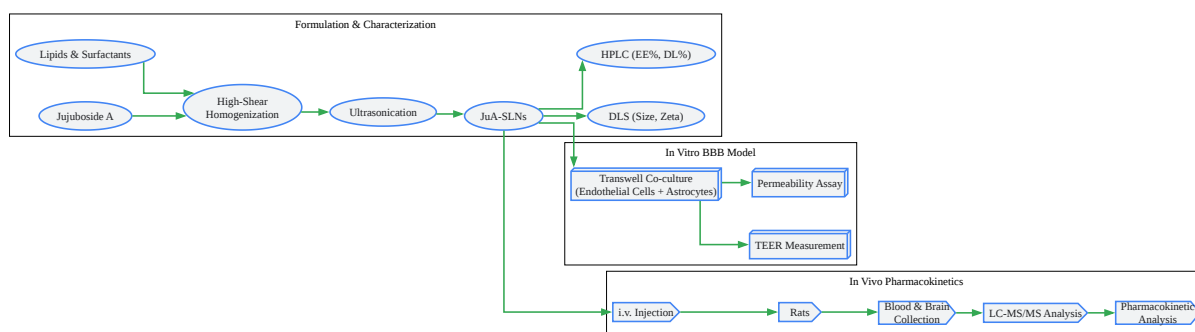

[Click to download full resolution via product page](#)

Caption: Experimental workflow for developing and evaluating JuA-loaded SLNs.

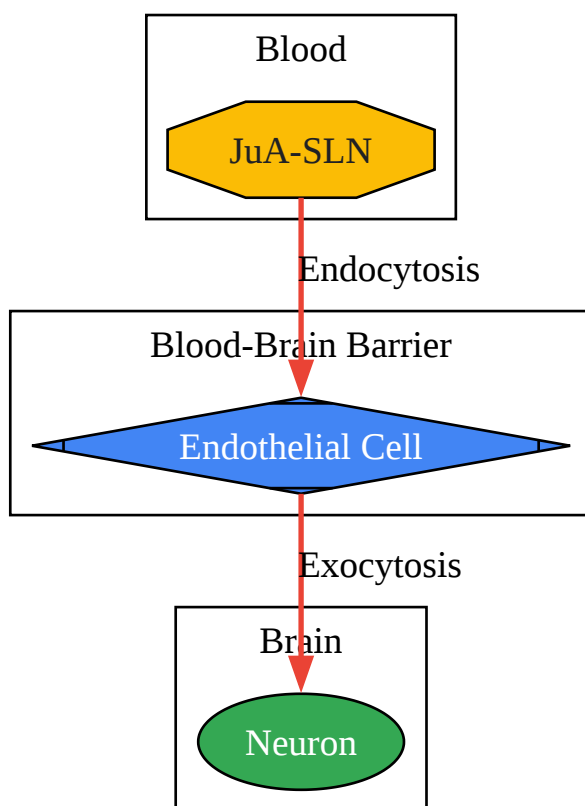

[Click to download full resolution via product page](#)

Caption: Proposed mechanism of JuA-SLN transport across the BBB.

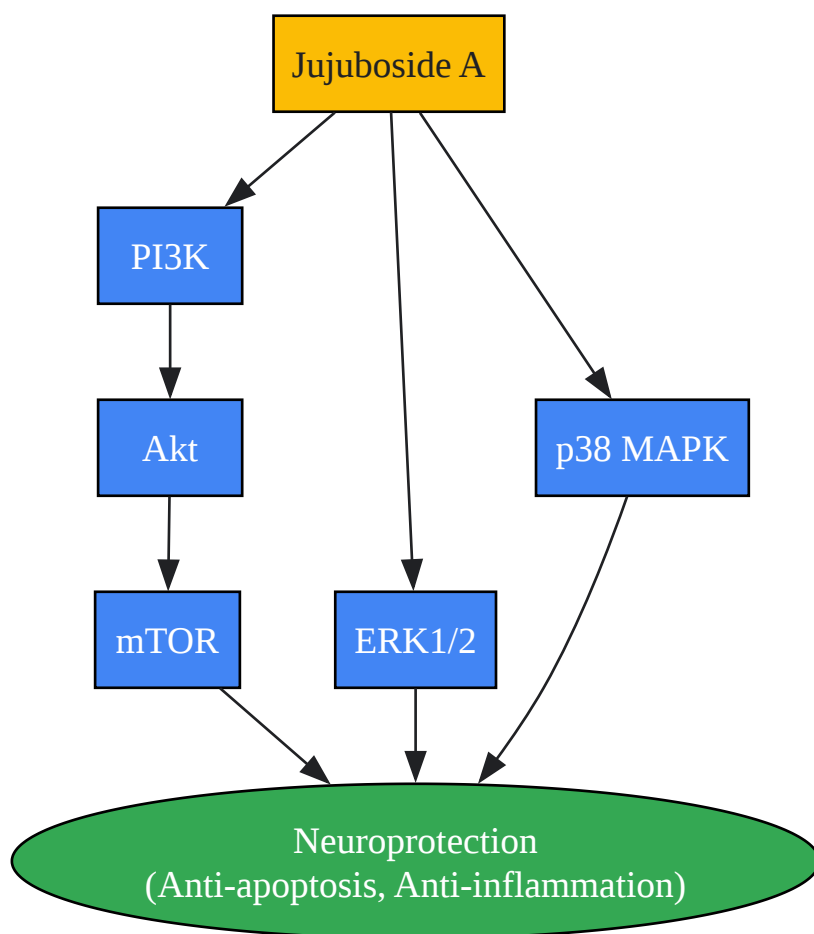

[Click to download full resolution via product page](#)

Caption: Potential neuroprotective signaling pathways of Jujuboside A.[15][16]

Need Custom Synthesis?

BenchChem offers custom synthesis for rare earth carbides and specific isotopic labeling.

Email: info@benchchem.com or [Request Quote Online](#).

References

- 1. Jujuboside A | CAS#:55466-04-1 | Chemsrce [chemsrc.com]
- 2. Jujuboside A | C58H94O26 | CID 51346169 - PubChem [pubchem.ncbi.nlm.nih.gov]
- 3. Jujuboside A1 | C58H94O26 | CID 101709344 - PubChem [pubchem.ncbi.nlm.nih.gov]

- 4. [PDF] Natural Products as Alternative Choices for P-Glycoprotein (P-gp) Inhibition | Semantic Scholar [semanticscholar.org]
- 5. Natural Products as Alternative Choices for P-Glycoprotein (P-gp) Inhibition - PMC [pmc.ncbi.nlm.nih.gov]
- 6. A Comprehensive Study on Nanoparticle Drug Delivery to the Brain: Application of Machine Learning Techniques - PMC [pmc.ncbi.nlm.nih.gov]
- 7. researchgate.net [researchgate.net]
- 8. benchchem.com [benchchem.com]
- 9. In vitro model of the blood-brain barrier established by co-culture of primary cerebral microvascular endothelial and astrocyte cells - PMC [pmc.ncbi.nlm.nih.gov]
- 10. mdpi.com [mdpi.com]
- 11. mdpi.com [mdpi.com]
- 12. A novel 4-cell in-vitro blood-brain barrier model and its characterization by confocal microscopy and TEER measurement - PMC [pmc.ncbi.nlm.nih.gov]
- 13. In vitro models of the blood–brain barrier: An overview of commonly used brain endothelial cell culture models and guidelines for their use - PMC [pmc.ncbi.nlm.nih.gov]
- 14. Exploring the potential of saponins as adjuvants in lipid-nanoparticle-based mRNA vaccines - PMC [pmc.ncbi.nlm.nih.gov]
- 15. Jujuboside A Protects H9C2 Cells from Isoproterenol-Induced Injury via Activating PI3K/Akt/mTOR Signaling Pathway - PMC [pmc.ncbi.nlm.nih.gov]
- 16. Jujuboside A Exhibits an Antiepileptogenic Effect in the Rat Model via Protection against Traumatic Epilepsy-Induced Oxidative Stress and Inflammatory Responses - PMC [pmc.ncbi.nlm.nih.gov]
- To cite this document: BenchChem. [Technical Support Center: Enhancing Brain Delivery of Jujuboside A]. BenchChem, [2025]. [Online PDF]. Available at: [https://www.benchchem.com/product/b1673115#overcoming-poor-blood-brain-barrier-penetration-of-jujuboside-a]

Disclaimer & Data Validity:

The information provided in this document is for Research Use Only (RUO) and is strictly not intended for diagnostic or therapeutic procedures. While BenchChem strives to provide accurate protocols, we make no warranties, express or implied, regarding the fitness of this product for every specific experimental setup.

Technical Support: The protocols provided are for reference purposes. Unsure if this reagent suits your experiment? [[Contact our Ph.D. Support Team for a compatibility check](#)]

Need Industrial/Bulk Grade? [Request Custom Synthesis Quote](#)

BenchChem

Our mission is to be the trusted global source of essential and advanced chemicals, empowering scientists and researchers to drive progress in science and industry.

Contact

Address: 3281 E Guasti Rd

Ontario, CA 91761, United States

Phone: (601) 213-4426

Email: info@benchchem.com