

Technical Support Center: Diethyl Chlorophosphite Reactions

Author: BenchChem Technical Support Team. **Date:** December 2025

Compound of Interest

Compound Name: Diethyl chlorophosphite

Cat. No.: B120558

[Get Quote](#)

Welcome to the technical support center for **diethyl chlorophosphite**. This resource is designed for researchers, scientists, and drug development professionals. Here you will find troubleshooting guides and frequently asked questions to address common issues encountered during phosphorylation reactions, with a specific focus on the critical role of base selection.

Frequently Asked Questions (FAQs)

Q1: What is the primary role of a base in reactions with **diethyl chlorophosphite**?

A1: In phosphorylation reactions using **diethyl chlorophosphite**, a base serves as an acid scavenger.[1][2] The reaction between an alcohol (ROH) and **diethyl chlorophosphite**, (EtO)₂P(O)Cl, generates hydrochloric acid (HCl) as a byproduct.[3] The base neutralizes this HCl, preventing it from protonating the starting materials or the desired product, which could otherwise lead to side reactions or inhibit the reaction from proceeding to completion.[2]

Q2: Which bases are commonly used, and how do I choose the right one?

A2: Common bases include tertiary amines like triethylamine (TEA), pyridine, and N,N-diisopropylethylamine (DIPEA or Hünig's base).[2][4]

- Triethylamine (TEA): A versatile and common choice for routine phosphorylations. It is sufficiently basic to scavenge HCl but can sometimes act as a nucleophile, leading to side products.[4]

- Pyridine: Often used when a milder base is required. Besides being a base, pyridine can also act as a nucleophilic catalyst, potentially accelerating the reaction by forming a more reactive acyl pyridinium intermediate.[5]
- DIPEA (Hünig's Base): A non-nucleophilic, sterically hindered base.[4] It is an excellent choice when dealing with sensitive substrates where nucleophilic attack from the base itself is a concern.[2][4]

The choice depends on the substrate's sensitivity and the desired reactivity. For robust primary alcohols, TEA is often sufficient. For more sensitive or sterically hindered substrates, the non-nucleophilic nature of DIPEA is advantageous.

Q3: Can the choice of base affect my reaction yield and purity?

A3: Absolutely. The base's properties—basicity, nucleophilicity, and steric hindrance—directly impact the reaction's outcome. An inappropriate base can lead to low yields, the formation of byproducts, or failure of the reaction. For instance, a base that is too weakly basic may not effectively neutralize the HCl generated, slowing or stopping the reaction. Conversely, a nucleophilic base like triethylamine can sometimes compete with the alcohol, leading to unwanted side products.[4]

Troubleshooting Guide

This guide addresses specific issues that may arise during phosphorylation with **diethyl chlorophosphite**.

Issue 1: Low or No Product Yield

- Possible Cause 1: Inadequate Base Strength or Amount.
 - Troubleshooting: Ensure you are using at least one equivalent of the base to neutralize the generated HCl. If the substrate itself is acidic, additional base may be required. Consider switching to a stronger base if you suspect incomplete acid scavenging is the issue.
- Possible Cause 2: Base-Related Side Reactions.

- Troubleshooting: If you are using a nucleophilic base like triethylamine with a sensitive substrate, the base may be reacting with your starting material or **diethyl chlorophosphite**.^[4]
- Solution: Switch to a non-nucleophilic, sterically hindered base like DIPEA (Hünig's base).^[4]
- Possible Cause 3: Hydrolysis of **Diethyl Chlorophosphite**.
 - Troubleshooting: **Diethyl chlorophosphite** is sensitive to moisture. Ensure all glassware is oven-dried and the reaction is run under an inert atmosphere (e.g., nitrogen or argon). Ensure your solvent and base are anhydrous. Water will hydrolyze the reagent, rendering it inactive.

Issue 2: Multiple Spots on TLC / Impure Product Mixture

- Possible Cause 1: Formation of Pyrophosphate Byproducts.
 - Troubleshooting: The desired phosphate product can sometimes react with another molecule of **diethyl chlorophosphite**, especially if there is an excess of the phosphorylating agent or if the base is not optimal. This leads to the formation of pyrophosphates.
 - Solution: Try adding the **diethyl chlorophosphite** slowly (dropwise) to the solution of your alcohol and base at a low temperature (e.g., 0 °C) to control the reaction rate and minimize side reactions.
- Possible Cause 2: Substrate Degradation.
 - Troubleshooting: If your substrate is sensitive to acid or base, the reaction conditions may be causing it to degrade.
 - Solution: Use a milder, non-nucleophilic base like pyridine or DIPEA. Run the reaction at a lower temperature and monitor its progress closely by TLC to avoid prolonged reaction times.

Data Presentation: Impact of Base on Phosphorylation Yield

The following table summarizes representative yields for the phosphorylation of a generic primary alcohol using **diethyl chlorophosphate** under different basic conditions. Note: These are illustrative values and actual yields will vary based on the specific substrate and reaction conditions.

Base	pKa of Conjugate Acid	Steric Hindrance	Typical Yield (%)	Comments
Pyridine	5.25	Low	75-85%	Mild; can act as a nucleophilic catalyst. ^[5] Good for sensitive substrates.
Triethylamine (TEA)	10.75	Moderate	80-95%	Common and effective, but can cause side reactions due to its nucleophilicity. ^{[2][4]}
DIPEA (Hünig's Base)	11.0	High	85-98%	Strongly basic yet non-nucleophilic. ^[4] Excellent for preventing base-related side reactions.

Experimental Protocols

General Protocol for the Phosphorylation of a Primary Alcohol

This protocol provides a general methodology for phosphorylating a primary alcohol using **diethyl chlorophosphite** and a tertiary amine base.

Materials:

- Primary alcohol (1.0 eq)
- Anhydrous dichloromethane (DCM) or tetrahydrofuran (THF)
- **Diethyl chlorophosphite** (1.1 - 1.2 eq)
- Base (e.g., Triethylamine or DIPEA, 1.2 - 1.5 eq)
- Anhydrous sodium sulfate or magnesium sulfate
- Saturated aqueous ammonium chloride (NH₄Cl) solution

Procedure:

- Preparation: Ensure all glassware is thoroughly oven-dried and assembled under an inert atmosphere (N₂ or Ar).
- Reaction Setup: To a round-bottom flask equipped with a magnetic stir bar, add the primary alcohol (1.0 eq) and dissolve it in anhydrous DCM.
- Cooling: Cool the solution to 0 °C using an ice-water bath.
- Addition of Base: Add the selected base (e.g., DIPEA, 1.2 eq) to the stirred solution.
- Addition of Phosphorylating Agent: Add **diethyl chlorophosphite** (1.1 eq) dropwise to the reaction mixture over 5-10 minutes. Ensure the internal temperature does not rise significantly.
- Reaction Monitoring: Allow the reaction to stir at 0 °C for 30 minutes, then warm to room temperature. Monitor the reaction's progress using Thin Layer Chromatography (TLC). The reaction is typically complete within 1-4 hours.

- **Workup:** Once the reaction is complete, cool the mixture back to 0 °C and quench by the slow addition of saturated aqueous NH₄Cl solution.
- **Extraction:** Transfer the mixture to a separatory funnel. Separate the layers and extract the aqueous layer twice with DCM.
- **Drying and Concentration:** Combine the organic layers, dry over anhydrous sodium sulfate, filter, and concentrate under reduced pressure to yield the crude product.
- **Purification:** Purify the crude product by flash column chromatography on silica gel to obtain the desired diethyl phosphate ester.

Visualizations

Reaction Mechanism and Role of the Base

The diagram below illustrates the general mechanism for the phosphorylation of an alcohol with **diethyl chlorophosphate**, highlighting the essential role of the base in neutralizing the HCl byproduct.

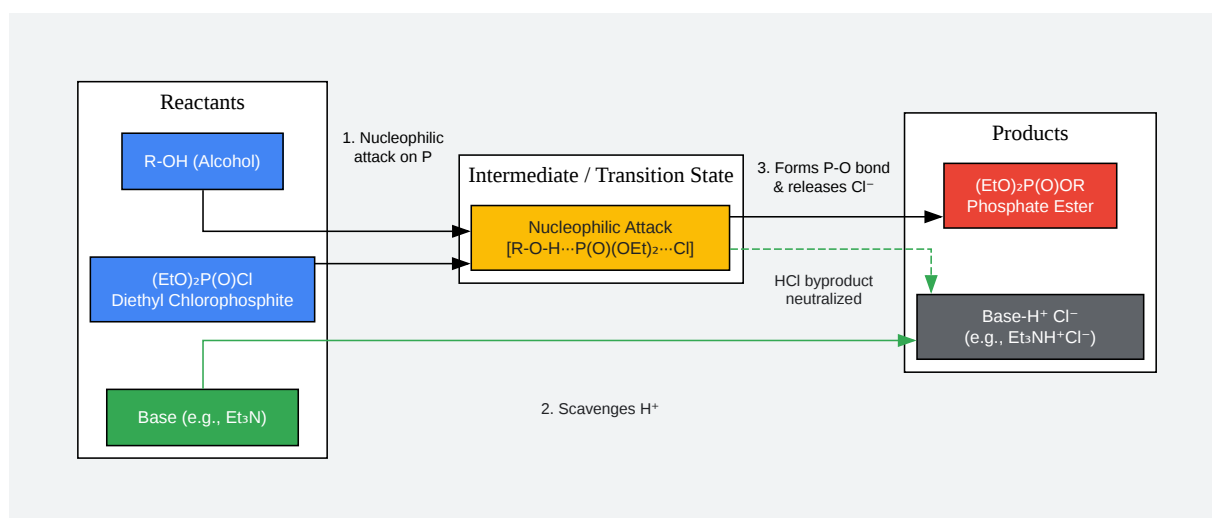

[Click to download full resolution via product page](#)

Caption: General mechanism of alcohol phosphorylation using **diethyl chlorophosphite**.

Troubleshooting Workflow for Low Yield

This decision tree provides a logical workflow for diagnosing the cause of low product yield in your phosphorylation reaction.

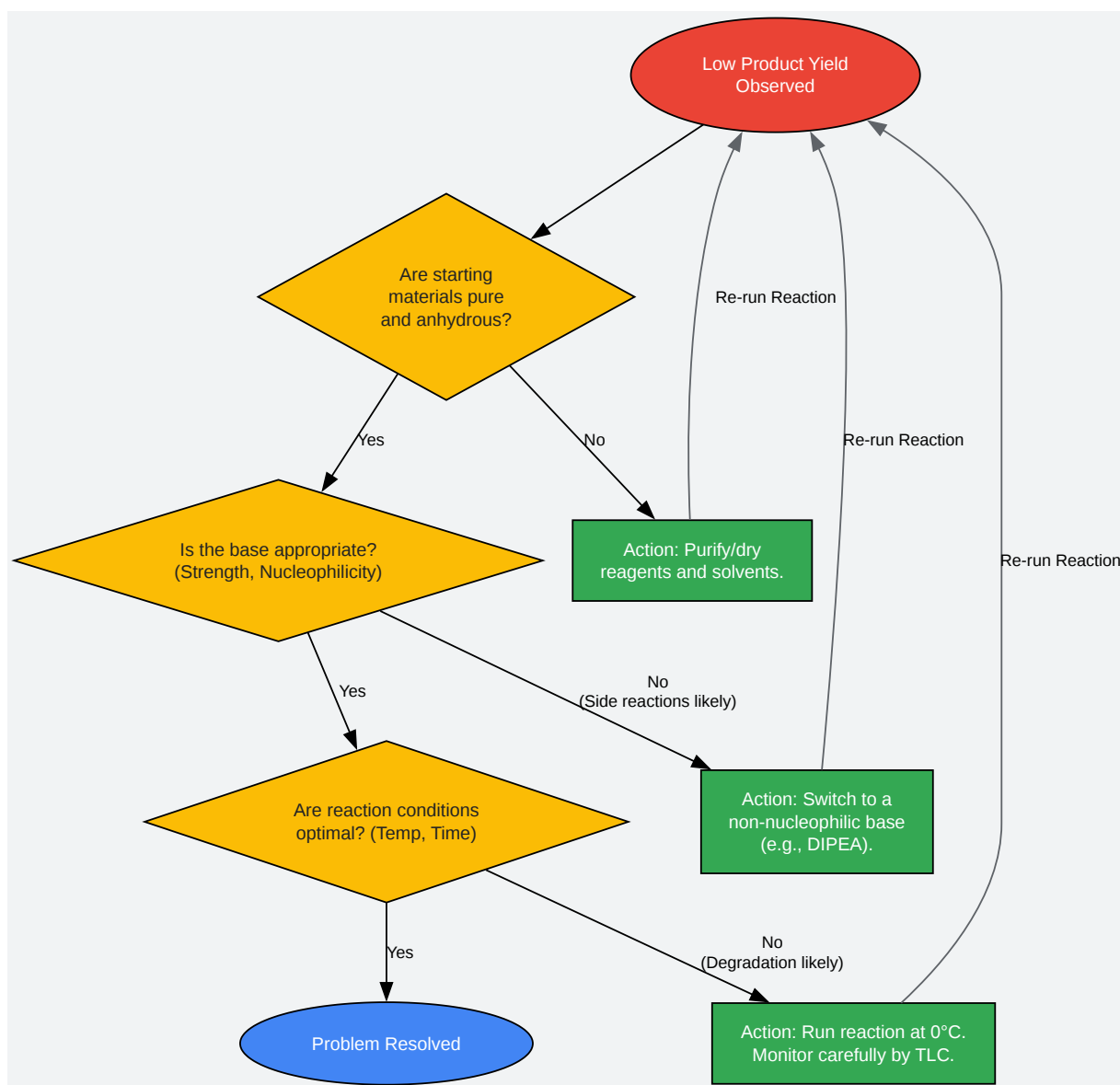

[Click to download full resolution via product page](#)

Caption: Decision tree for troubleshooting low yield in phosphorylation reactions.

Need Custom Synthesis?

BenchChem offers custom synthesis for rare earth carbides and specific isotopic labeling.

Email: info@benchchem.com or [Request Quote Online](#).

References

- 1. researchgate.net [researchgate.net]
- 2. bdmaee.net [bdmaee.net]
- 3. Diethyl phosphorochloridate - Wikipedia [en.wikipedia.org]
- 4. organic chemistry - Can triethylamine/pyridine be used in the synthesis of Labetalol? - Chemistry Stack Exchange [chemistry.stackexchange.com]
- 5. reddit.com [reddit.com]
- To cite this document: BenchChem. [Technical Support Center: Diethyl Chlorophosphite Reactions]. BenchChem, [2025]. [Online PDF]. Available at: [https://www.benchchem.com/product/b120558#impact-of-base-choice-on-diethyl-chlorophosphite-reactivity]

Disclaimer & Data Validity:

The information provided in this document is for Research Use Only (RUO) and is strictly not intended for diagnostic or therapeutic procedures. While BenchChem strives to provide accurate protocols, we make no warranties, express or implied, regarding the fitness of this product for every specific experimental setup.

Technical Support: The protocols provided are for reference purposes. Unsure if this reagent suits your experiment? [[Contact our Ph.D. Support Team for a compatibility check](#)]

Need Industrial/Bulk Grade? [Request Custom Synthesis Quote](#)

BenchChem

Our mission is to be the trusted global source of essential and advanced chemicals, empowering scientists and researchers to drive progress in science and industry.

Contact

Address: 3281 E Guasti Rd

Ontario, CA 91761, United States

Phone: (601) 213-4426

Email: info@benchchem.com