

# Technical Support Center: Celastrol Off-Target Effects in Cellular Models

**Author:** BenchChem Technical Support Team. **Date:** December 2025

## Compound of Interest

Compound Name: *celaphanol A*

Cat. No.: *B026724*

[Get Quote](#)

Disclaimer: The information provided in this technical support center pertains to Celastrol, as searches for "**Celaphanol A**" did not yield relevant scientific literature. It is assumed that "Celastrol" was the intended compound of interest.

This technical support center provides researchers, scientists, and drug development professionals with troubleshooting guides and frequently asked questions (FAQs) regarding the off-target effects of Celastrol in cellular models.

## Frequently Asked Questions (FAQs)

Q1: What are the known off-target effects of Celastrol in cellular models?

A1: Celastrol is known to have a multi-target mechanism of action, affecting various signaling pathways beyond its intended targets. Network pharmacology analyses and experimental studies have predicted and validated several off-target proteins. These include proteins involved in cancer, connective tissue disorders, and cell death and survival.[1] Key signaling proteins regulated by Celastrol include MMP-9, COX-2, c-Myc, TGF- $\beta$ , c-JUN, JAK-1, JAK-3, IKK- $\beta$ , SYK, MMP-3, JNK, and MEK1.[1]

Q2: In which cellular models have the off-target effects of Celastrol been studied?

A2: The cytotoxic and off-target effects of Celastrol have been investigated in various cell lines. For instance, its impact on cell viability has been assessed in lymphoblastoid cells.[2] The

choice of cellular model is critical, and both monolayer and three-dimensional cell cultures have been used to evaluate cellular toxicity for different compounds.[3]

Q3: What are common assays to measure the cytotoxicity of Celastrol?

A3: Several colorimetric and fluorescence-based assays are commonly used to measure Celastrol-induced cytotoxicity. These include:

- MTT Assay: This assay measures the metabolic activity of cells, which is proportional to the number of viable cells.[2][4]
- LDH Assay: This assay quantifies the release of lactate dehydrogenase (LDH) from damaged cells into the culture medium, which is an indicator of compromised cell membrane integrity.[5][6]
- ATP Assay: This assay measures the level of intracellular ATP, which correlates with cell viability. It is considered highly sensitive.[4]

## Troubleshooting Guides

Issue 1: High variability in cytotoxicity assay results.

- Possible Cause: Inconsistent cell seeding density.
- Troubleshooting Step: Ensure a uniform cell seeding density across all wells of the microplate. It is crucial to establish a suitable cell seeding density before conducting the experiment.[2]
- Possible Cause: Interference of Celastrol with the assay reagents.
- Troubleshooting Step: Run appropriate controls, including wells with Celastrol and the assay reagent but without cells, to check for any direct chemical interference. Some compounds can interfere with MTT reagents, leading to inaccurate estimations of cell viability.[4]
- Possible Cause: Differences in cell culture confluency.
- Troubleshooting Step: Standardize the cell confluency at the time of treatment. Cells at different growth phases can exhibit varying sensitivities to cytotoxic compounds.

Issue 2: Unexpected or contradictory results in different cell lines.

- Possible Cause: Cell line-specific differences in signaling pathways and protein expression.
- Troubleshooting Step: Characterize the expression levels of known Celastrol targets and off-targets in your specific cell lines. The cellular context, including the expression of signaling proteins, can significantly influence the drug's effect.[1]
- Possible Cause: Different experimental conditions.
- Troubleshooting Step: Carefully document and standardize all experimental parameters, including incubation times, solvent controls, and passage number of the cell lines.

## Quantitative Data Summary

Table 1: Cytotoxicity of Celastrol in Lymphoblastoid Cells (MTT Assay)[2]

Concentration ( $\mu\text{M}$ )	Exposure Time (hours)	Reduction in MTT (%)
0.8	4	Noticeable reduction
0.8	24	~70%
0.2	24	Sufficient to affect viability
0.5	24	~50%

## Key Experimental Protocols

### 1. MTT Assay for Cellular Viability

This protocol is adapted from a method used to analyze the viability of lymphoblastoid cells exposed to Celastrol.[2]

- Materials:
  - Lymphoblastoid cells
  - Complete cell culture medium

- Celastrol stock solution (dissolved in a suitable vehicle, e.g., DMSO)
- MTT (3-(4,5-dimethylthiazol-2-yl)-2,5-diphenyltetrazolium bromide) solution
- Solubilization buffer (e.g., DMSO or a solution of SDS in HCl)
- 96-well microplate
- Microplate reader
- Procedure:
  - Seed the cells in a 96-well plate at a pre-determined optimal density and allow them to adhere overnight.
  - Prepare serial dilutions of Celastrol in complete culture medium.
  - Remove the old medium from the wells and add the medium containing different concentrations of Celastrol. Include vehicle-only controls.
  - Incubate the plate for the desired exposure time (e.g., 4 or 24 hours).<sup>[2]</sup>
  - Add MTT solution to each well and incubate for 2-4 hours at 37°C.
  - Add the solubilization buffer to dissolve the formazan crystals.
  - Measure the absorbance at the appropriate wavelength using a microplate reader.
  - Calculate cell viability as a percentage of the vehicle-treated control.

## 2. LDH Cytotoxicity Assay

This protocol is based on the general principles of LDH release assays.<sup>[5][6]</sup>

- Materials:
  - Target cells
  - Complete cell culture medium

- Celastrol stock solution
- LDH assay kit (containing LDH substrate, cofactor, and dye)
- 96-well microplate
- Microplate reader
- Procedure:
  - Plate the cells in a 96-well plate and treat them with various concentrations of Celastrol as described for the MTT assay. Include positive controls (cells treated with a known cytotoxic agent) and negative controls (untreated cells).
  - After the incubation period, carefully transfer a portion of the cell culture supernatant to a new 96-well plate.[\[6\]](#)
  - Add the LDH cytotoxicity reagent from the kit to each well containing the supernatant.[\[6\]](#)
  - Incubate the plate at room temperature for the time specified in the kit's instructions.
  - Measure the absorbance at the recommended wavelength.
  - Calculate the percentage of cytotoxicity based on the LDH released from treated cells compared to the controls.

## Visualizations

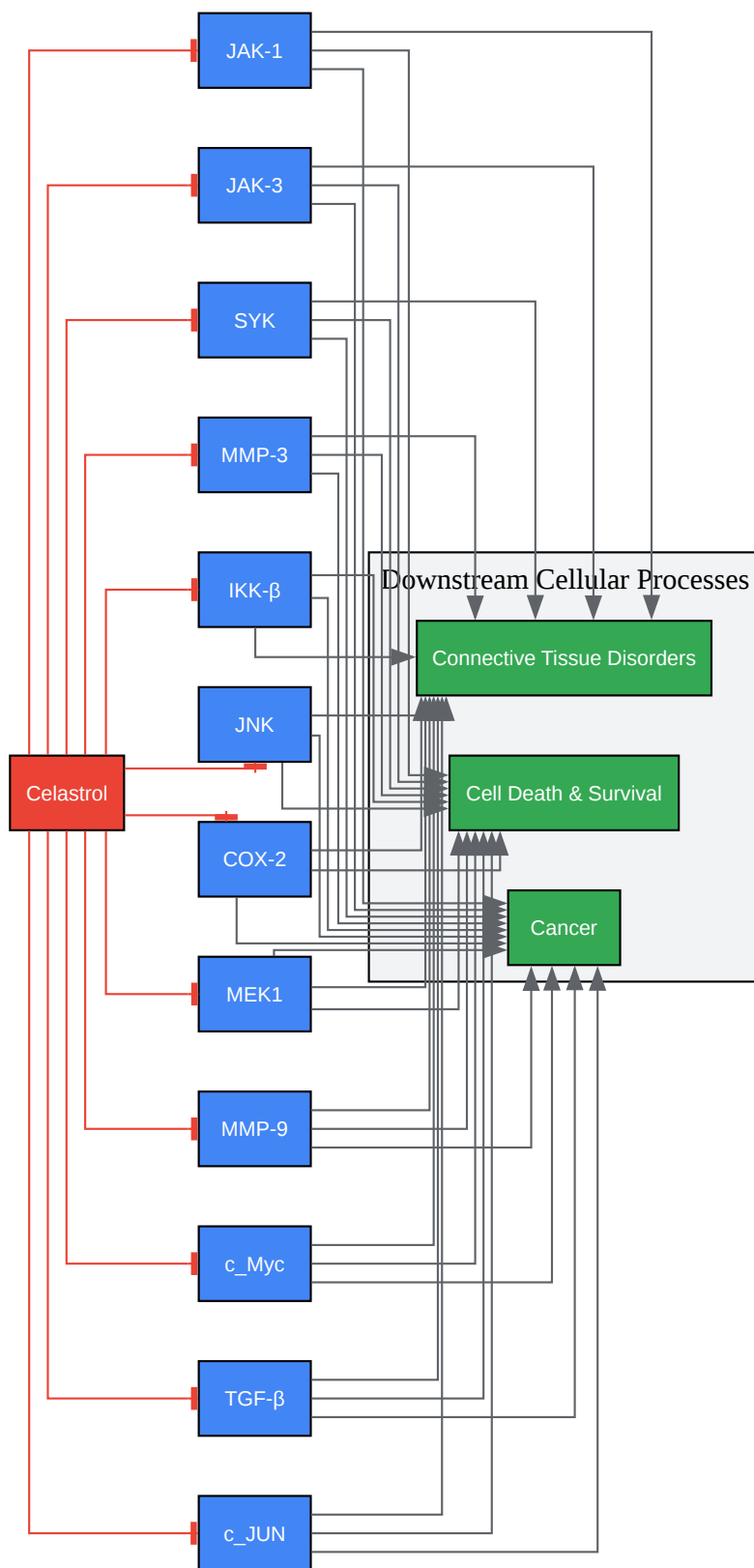

[Click to download full resolution via product page](#)

Caption: Predicted off-target signaling pathways of Celastrol.

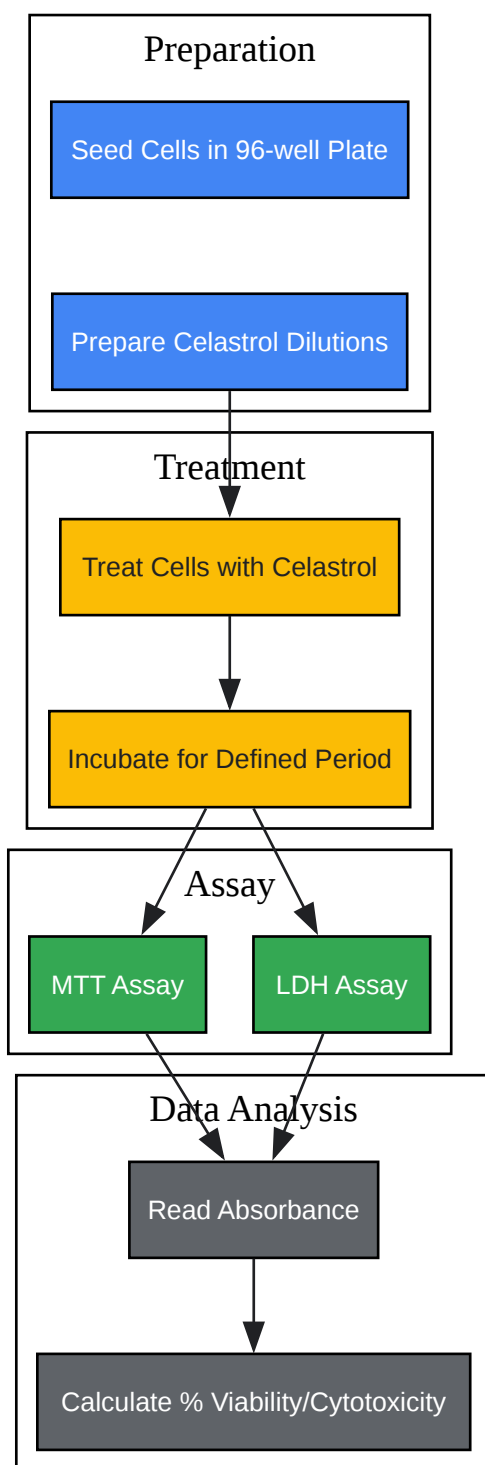

[Click to download full resolution via product page](#)

Caption: General workflow for cytotoxicity assessment.

### Need Custom Synthesis?

BenchChem offers custom synthesis for rare earth carbides and specific isotopic labeling.

Email: [info@benchchem.com](mailto:info@benchchem.com) or [Request Quote Online](#).

## References

- 1. Mechanism of action of celastrol against rheumatoid arthritis: A network pharmacology analysis - PubMed [[pubmed.ncbi.nlm.nih.gov](https://pubmed.ncbi.nlm.nih.gov)]
- 2. A cellular viability assay to monitor drug toxicity - PubMed [[pubmed.ncbi.nlm.nih.gov](https://pubmed.ncbi.nlm.nih.gov)]
- 3. [researchgate.net](https://www.researchgate.net) [[researchgate.net](https://www.researchgate.net)]
- 4. Cell Culture-Based Assessment of Toxicity and Therapeutics of Phytochemical Antioxidants - PMC [[pubmed.ncbi.nlm.nih.gov](https://pubmed.ncbi.nlm.nih.gov)]
- 5. Cytotoxicity Assays | Thermo Fisher Scientific - US [[thermofisher.com](https://www.thermofisher.com)]
- 6. LDH Cytotoxicity Assay Kit [[cellbiolabs.com](https://www.cellbiolabs.com)]
- To cite this document: BenchChem. [Technical Support Center: Celastrol Off-Target Effects in Cellular Models]. BenchChem, [2025]. [Online PDF]. Available at: [<https://www.benchchem.com/product/b026724#celaphanol-a-off-target-effects-in-cellular-models>]

---

### Disclaimer & Data Validity:

The information provided in this document is for Research Use Only (RUO) and is strictly not intended for diagnostic or therapeutic procedures. While BenchChem strives to provide accurate protocols, we make no warranties, express or implied, regarding the fitness of this product for every specific experimental setup.

**Technical Support:** The protocols provided are for reference purposes. Unsure if this reagent suits your experiment? [[Contact our Ph.D. Support Team for a compatibility check](#)]

**Need Industrial/Bulk Grade?** [Request Custom Synthesis Quote](#)



# BenchChem

Our mission is to be the trusted global source of essential and advanced chemicals, empowering scientists and researchers to drive progress in science and industry.

## Contact

Address: 3281 E Guasti Rd

Ontario, CA 91761, United States

Phone: (601) 213-4426

Email: [info@benchchem.com](mailto:info@benchchem.com)