

Technical Support Center: CK1-IN-2 Kinase Assays

Author: BenchChem Technical Support Team. **Date:** December 2025

Compound of Interest

Compound Name: CK1-IN-2

Cat. No.: B15545021

[Get Quote](#)

This guide provides researchers, scientists, and drug development professionals with comprehensive troubleshooting strategies and frequently asked questions for **CK1-IN-2** kinase assays.

Frequently Asked Questions (FAQs)

Q1: What is **CK1-IN-2** and what are its primary targets?

CK1-IN-2 is a potent inhibitor of Casein Kinase 1 (CK1). It exhibits inhibitory activity against several CK1 isoforms. Published data indicates it also has off-target activity against p38 α mitogen-activated protein kinase.[1][2][3]

Q2: What is the recommended solvent and storage condition for **CK1-IN-2**?

CK1-IN-2 is soluble in DMSO. For long-term storage, it is recommended to store the powder at -20°C for up to three years. In solvent, store at -80°C for up to six months or at -20°C for one month.[2] To ensure the integrity of the compound, it is advisable to aliquot the stock solution to avoid repeated freeze-thaw cycles.

Q3: I am observing no inhibition or weak inhibition of my target CK1 isoform. What are the possible causes?

Several factors could contribute to this issue:

- **Suboptimal Inhibitor Concentration:** Ensure you are using an appropriate concentration of **CK1-IN-2** for your specific CK1 isoform. Refer to the IC50 values in Table 1 as a starting point and perform a dose-response experiment to determine the optimal concentration for your assay conditions.
- **Inactive Inhibitor:** Verify that the inhibitor has been stored correctly and has not degraded. Prepare fresh stock solutions if there is any doubt about the stability of the current stock.
- **Incorrect ATP Concentration:** The inhibitory potential of ATP-competitive inhibitors is influenced by the ATP concentration in the assay. If the ATP concentration is too high, it can outcompete the inhibitor, leading to reduced apparent inhibition. It is recommended to use an ATP concentration at or near the K_m for the specific CK1 isoform.
- **Enzyme Activity Issues:** Confirm that the CK1 enzyme is active. Include a positive control (a known potent CK1 inhibitor) and a negative control (vehicle only) in your experiment to validate the assay setup.

Q4: I am observing unexpected or inconsistent results in my cellular assay. What could be the problem?

Cellular assays introduce additional complexities. Here are some common troubleshooting points:

- **Off-Target Effects:** **CK1-IN-2** is known to inhibit p38 α .^{[1][2][3]} If your cellular model has an active p38 MAPK pathway, the observed phenotype may be a result of p38 α inhibition. Consider using a more selective p38 inhibitor as a control to dissect the effects. Common off-target effects of p38 inhibitors can include liver toxicity, CNS side effects, and skin rashes in broader applications, and in cellular assays may lead to unexpected phenotypes.^[4]
- **Cell Permeability and Stability:** Ensure that **CK1-IN-2** is effectively penetrating the cell membrane and remains stable in your cell culture medium for the duration of the experiment.
- **Cellular Context:** The intricate network of signaling pathways within a cell can lead to compensatory mechanisms. Inhibition of CK1 might lead to the activation of other pathways that mask the expected phenotype.

- **Inconsistent Cell Handling:** Variations in cell density, passage number, or stimulation conditions can lead to inconsistent results. Maintain consistent cell culture practices.

Q5: My results show high background signal in the kinase assay. How can I reduce it?

High background can obscure the true signal. Consider the following:

- **Autophosphorylation of CK1:** Some CK1 isoforms exhibit autophosphorylation, which can contribute to the background signal, especially in assays that measure ATP consumption.
- **Non-specific Binding:** In filter-based assays, non-specific binding of [γ - 32 P]ATP or the phosphorylated substrate to the filter paper can be a source of high background. Ensure adequate washing steps are performed.
- **Reagent Quality:** Use high-quality reagents, including purified enzyme and substrate, to minimize contaminating activities.

Quantitative Data

Table 1: Inhibitory Potency (IC₅₀) of **CK1-IN-2**

Target	IC ₅₀ (nM)
CK1 α	123[1][2][3]
CK1 δ	19.8[1][2][3]
CK1 ϵ	26.8[1][2][3]
p38 α	74.3[1][2][3]

Experimental Protocols

In Vitro Kinase Assay Protocol (Radiometric)

This protocol provides a general framework for a radiometric in vitro kinase assay to determine the inhibitory activity of **CK1-IN-2**.

Materials:

- Purified recombinant CK1 isoform (e.g., CK1 δ)
- Specific peptide or protein substrate for the CK1 isoform
- **CK1-IN-2** stock solution (in DMSO)
- Kinase reaction buffer (e.g., 25 mM HEPES pH 7.5, 10 mM MgCl₂, 1 mM DTT)
- [γ -³²P]ATP
- ATP solution
- 96-well plates
- Phosphocellulose filter plates
- Stop solution (e.g., 75 mM phosphoric acid)
- Scintillation counter

Procedure:

- **Prepare Serial Dilutions:** Prepare a series of dilutions of **CK1-IN-2** in DMSO. A common starting point is a 10-point, 3-fold serial dilution from a high concentration (e.g., 100 μ M).
- **Assay Plate Setup:** In a 96-well plate, add the kinase reaction buffer.
- **Add Inhibitor:** Add the serially diluted **CK1-IN-2** or DMSO (vehicle control) to the appropriate wells.
- **Add Enzyme:** Add the purified CK1 enzyme to each well. Incubate for 10-15 minutes at room temperature to allow for inhibitor binding.
- **Initiate Reaction:** Start the kinase reaction by adding a mixture of the specific substrate and [γ -³²P]ATP. The final ATP concentration should be at or near the K_m for the specific CK1 isoform.

- Incubation: Incubate the plate at 30°C for a predetermined time, ensuring the reaction is in the linear range.
- Stop Reaction: Terminate the reaction by adding the stop solution.
- Filter and Wash: Transfer the reaction mixture to a phosphocellulose filter plate. The phosphorylated substrate will bind to the filter. Wash the filter plate multiple times with the stop solution to remove unincorporated [γ -³²P]ATP.
- Detection: Dry the filter plate, add scintillation cocktail to each well, and measure the radioactivity using a scintillation counter.
- Data Analysis: Calculate the percentage of inhibition for each **CK1-IN-2** concentration relative to the vehicle control and plot the data to determine the IC50 value.

Signaling Pathways and Experimental Workflows

Wnt Signaling Pathway

The Wnt signaling pathway is a crucial regulator of cell fate, proliferation, and differentiation. Casein Kinase 1 plays a key role in this pathway, both in the "off-state" by promoting the degradation of β -catenin and in the "on-state" by phosphorylating components of the receptor complex.

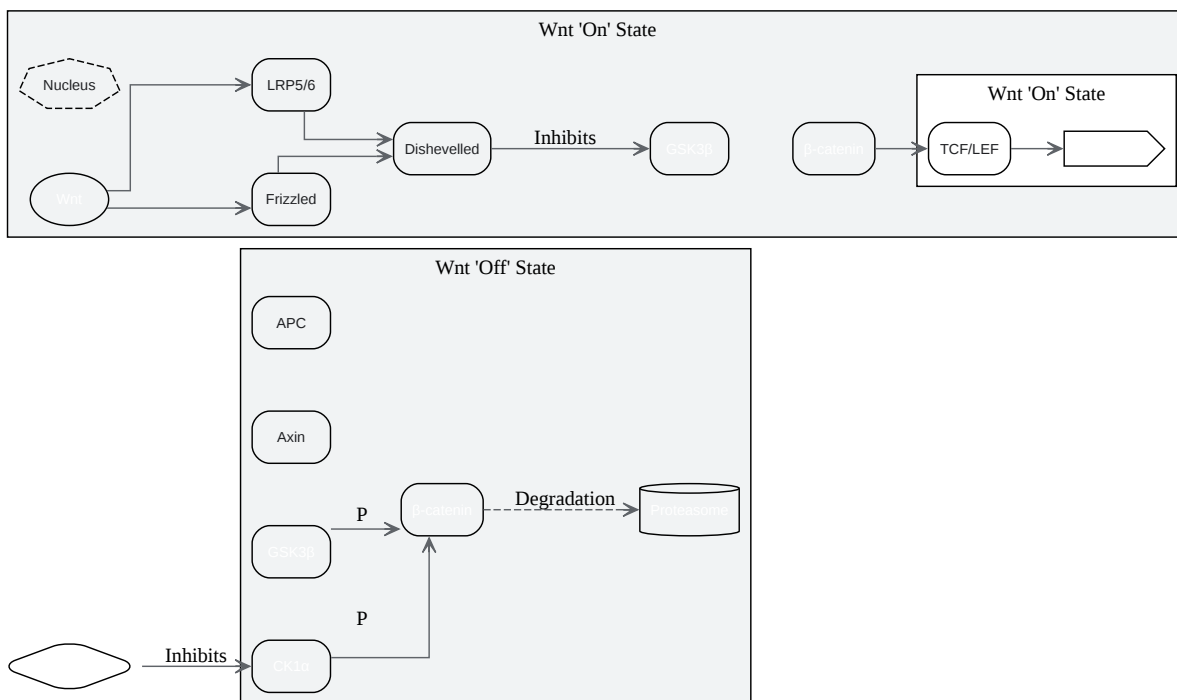

[Click to download full resolution via product page](#)

Wnt Signaling Pathway and the role of CK1.

Hedgehog Signaling Pathway

The Hedgehog (Hh) signaling pathway is essential for embryonic development and tissue homeostasis. CK1 is involved in the phosphorylation and activation of key components in this pathway, such as Smoothened (Smo).

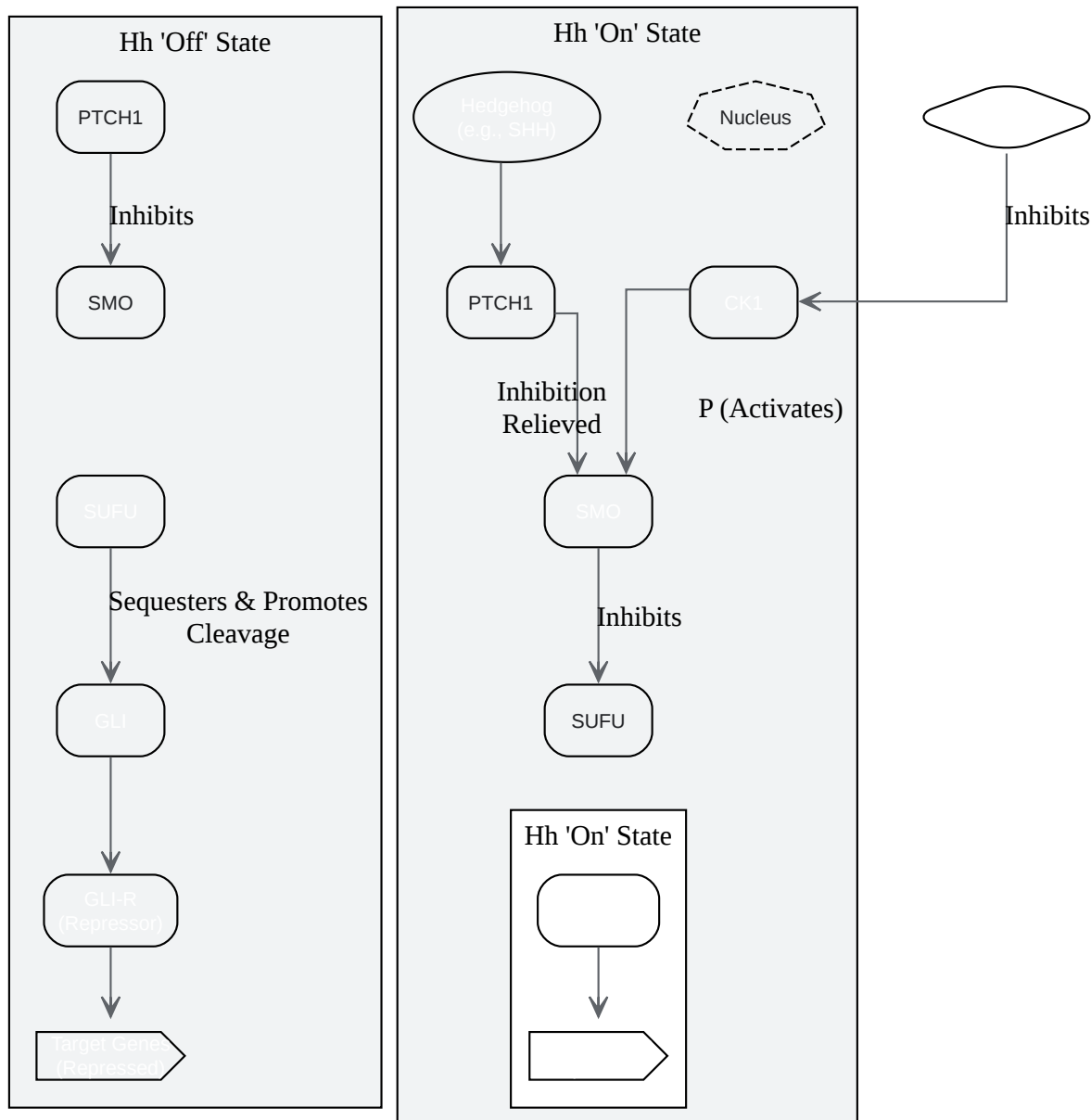

[Click to download full resolution via product page](#)

Hedgehog Signaling Pathway and the role of CK1.

Experimental Workflow Logic

This diagram illustrates a logical workflow for troubleshooting unexpected results in a cellular assay with **CK1-IN-2**.

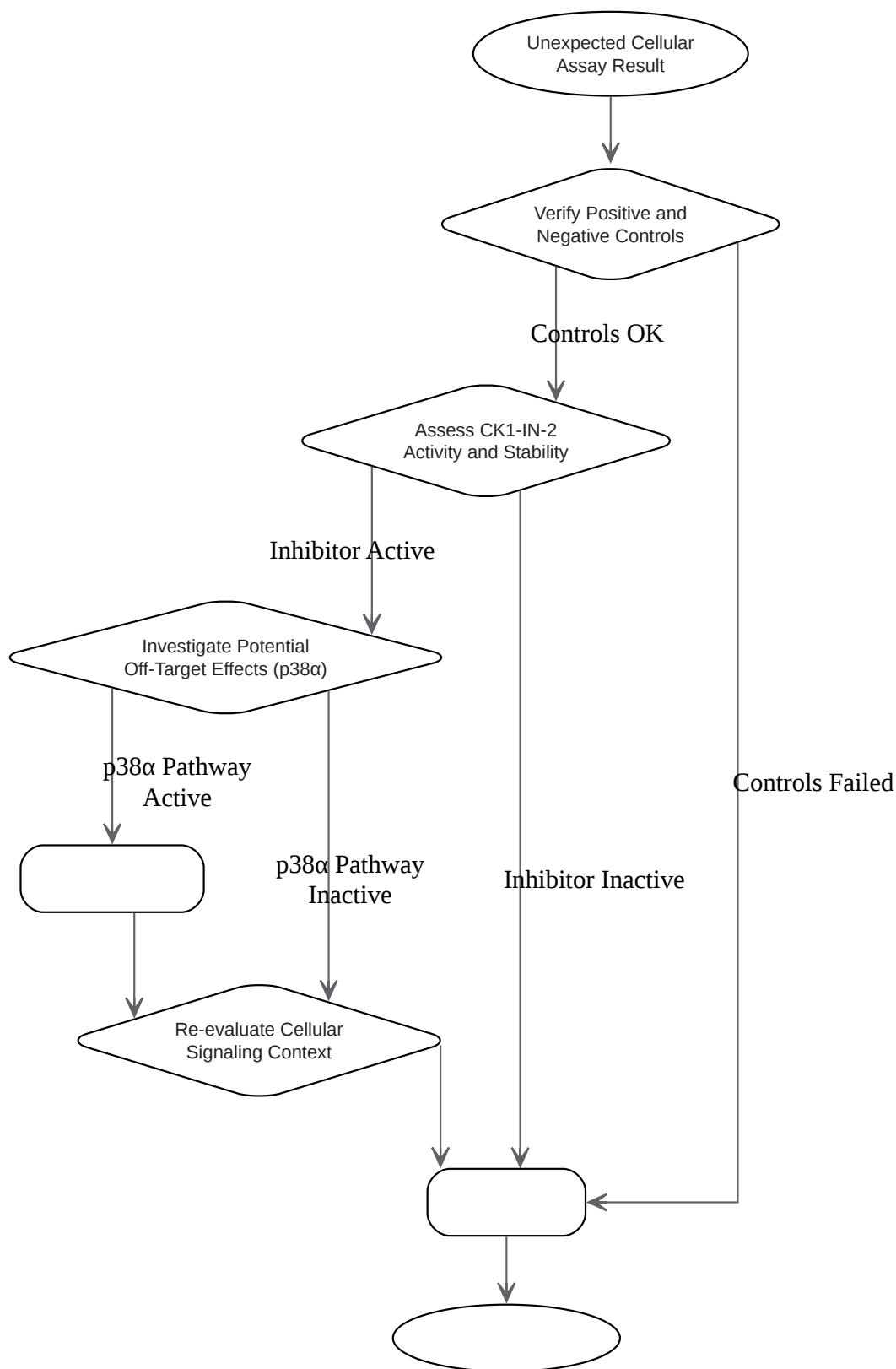

[Click to download full resolution via product page](#)

Logical workflow for troubleshooting cellular assays.

Need Custom Synthesis?

BenchChem offers custom synthesis for rare earth carbides and specific isotopic labeling.

Email: info@benchchem.com or [Request Quote Online](#).

References

- 1. Wnt signaling pathway diagram | The WNT Homepage [wnt.stanford.edu]
- 2. medchemexpress.com [medchemexpress.com]
- 3. medchemexpress.com [medchemexpress.com]
- 4. benchchem.com [benchchem.com]
- To cite this document: BenchChem. [Technical Support Center: CK1-IN-2 Kinase Assays]. BenchChem, [2025]. [Online PDF]. Available at: [https://www.benchchem.com/product/b15545021#troubleshooting-guide-for-ck1-in-2-kinase-assays]

Disclaimer & Data Validity:

The information provided in this document is for Research Use Only (RUO) and is strictly not intended for diagnostic or therapeutic procedures. While BenchChem strives to provide accurate protocols, we make no warranties, express or implied, regarding the fitness of this product for every specific experimental setup.

Technical Support: The protocols provided are for reference purposes. Unsure if this reagent suits your experiment? [[Contact our Ph.D. Support Team for a compatibility check](#)]

Need Industrial/Bulk Grade? [Request Custom Synthesis Quote](#)

BenchChem

Our mission is to be the trusted global source of essential and advanced chemicals, empowering scientists and researchers to drive progress in science and industry.

Contact

Address: 3281 E Guasti Rd

Ontario, CA 91761, United States

Phone: (601) 213-4426

Email: info@benchchem.com