

Technical Support Center: Bromobimane-Thiol Reactions

Author: BenchChem Technical Support Team. **Date:** December 2025

Compound of Interest

Compound Name: *Bromobimane*

Cat. No.: *B013751*

[Get Quote](#)

This technical support center provides troubleshooting guidance and frequently asked questions (FAQs) for researchers, scientists, and drug development professionals working with **bromobimane** derivatization of thiols.

Troubleshooting Guides

Issue: Low or No Fluorescent Signal

Possible Cause	Troubleshooting Step	Explanation
Incorrect pH	Ensure the reaction buffer pH is in the optimal range (typically pH 8.0-9.5).[1][2]	The reaction between bromobimane and thiols is pH-dependent, as the thiolate anion (R-S ⁻) is the reactive species.[3] A basic pH is required to deprotonate the thiol group.
Thiol Oxidation	Prepare samples fresh and consider using a reducing agent like Dithiothreitol (DTT) or Tris(2-carboxyethyl)phosphine (TCEP) prior to derivatization if disulfide bond formation is suspected.[4] Minimize exposure to air, especially at high pH.[5]	Thiols can oxidize to form disulfides, which are unreactive with bromobimane.
Reagent Degradation	Prepare bromobimane solutions fresh in a suitable solvent like acetonitrile and protect them from light.[2][6] Store stock solutions at low temperatures (-20°C).[5]	Bromobimane is light-sensitive and can degrade over time, leading to reduced reactivity.[5]
Insufficient Reagent	Use a sufficient excess of bromobimane (e.g., 10-fold or higher) relative to the thiol concentration.[1]	A molar excess of the labeling reagent ensures the reaction goes to completion.
Interfering Substances	If the sample contains other nucleophiles, consider a sample cleanup step.[7]	Compounds with reactive functional groups can compete with thiols for bromobimane, reducing the yield of the desired fluorescent product.

Issue: High Background Fluorescence

Possible Cause	Troubleshooting Step	Explanation
Hydrolysis of Bromobimane	Avoid excessively high pH (e.g., > 11) and prolonged reaction times.[2]	At high pH, bromobimane can hydrolyze, which may produce fluorescent side products.
Excess Reagent	After the reaction is complete, quench the excess bromobimane by adding a small thiol-containing molecule or by acidifying the solution.[3]	Unreacted bromobimane can contribute to background fluorescence.
Contaminated Reagents or Glassware	Use high-purity reagents and thoroughly cleaned glassware.	Fluorescent contaminants can interfere with the assay.

Frequently Asked Questions (FAQs)

Q1: What is the optimal pH for the reaction of **bromobimane** with thiols?

The optimal pH for the derivatization of thiols with **bromobimane** is typically in the range of 8.0 to 9.5.[1][2] This is because the reaction proceeds through a nucleophilic substitution where the thiolate anion ($R-S^-$) is the active nucleophile.[3] A basic pH is necessary to deprotonate the thiol group ($R-SH$), thereby increasing the concentration of the more reactive thiolate.

Q2: How does pH affect the reaction rate?

The reaction rate increases with pH up to a certain point (around pH 11).[2] However, at very high pH values, the reactivity of **bromobimane** with other functional groups can increase, and the stability of the reagent itself decreases due to hydrolysis, which can lead to unwanted side products and a more complex chromatogram.[2] Therefore, a compromise pH, such as 9.0, is often chosen to maintain a high reaction rate while ensuring selectivity for thiols.[2]

Q3: Can **bromobimane** react with other functional groups besides thiols?

While **bromobimane** is highly selective for thiols, at higher pH values, its reactivity with other nucleophilic functional groups can increase.[2] It is important to work within the recommended

pH range to ensure the selectivity of the labeling reaction.

Q4: How can I stop the derivatization reaction?

The reaction can be effectively stopped by acidifying the reaction mixture, for example, by adding methanesulfonic acid or acetic acid.[3][5] This protonates the thiolate, rendering it unreactive, and also helps to stabilize the **bromobimane** adducts for subsequent analysis.

Q5: What are some common interfering substances in **bromobimane**-thiol assays?

Interfering substances can include other nucleophilic compounds present in the sample that can react with **bromobimane**. Additionally, colored or turbid components in the sample can interfere with fluorescence detection.[7] Sample cleanup procedures, such as protein precipitation, may be necessary for complex biological samples.[7]

Quantitative Data Summary

Table 1: pH Optima for **Bromobimane** Derivatization of Various Thiols

Thiol	Optimal pH	Reference
Endogenous plasma thiols	9.5	[1]
Glutathione (GSH)	9.0-11.0 (9.0 recommended for clarity)	[2]
General Thiols	8.0	[3][5]

Table 2: Reaction Conditions for **Bromobimane** Derivatization

Parameter	Recommended Condition	Reference
pH	8.0 - 9.5	[1][2][3]
Reaction Time	10 - 15 minutes	[1][2][3]
Temperature	Room Temperature	[1][3]
Bromobimane Excess	10 to 70-fold molar excess	[1]
Solvent for Bromobimane	Acetonitrile	[3][6]
Quenching Agent	Methanesulfonic acid or Acetic acid	[3][5]

Experimental Protocols

Protocol 1: General Procedure for Derivatization of Low-Molecular-Weight Thiols

- **Sample Preparation:** Prepare a standard solution of the thiol of interest or your experimental sample in a suitable buffer. If necessary, reduce any disulfide bonds by pre-incubating the sample with a reducing agent like DTT or TCEP.
- **Reagent Preparation:** Prepare a fresh stock solution of monobromobimane (mBBr) in acetonitrile (e.g., 100-180 mM).[3] Protect this solution from light.
- **Derivatization Reaction:**
 - In a microcentrifuge tube, add your thiol-containing sample.
 - Add a reaction buffer to achieve a final pH between 8.0 and 9.5 (e.g., 50 mM HEPPS, 5 mM DTPA, pH 8.0).[5]
 - Add the mBBr solution to achieve a final concentration that is in stoichiometric excess (e.g., 2-3 mM mBBr for a 1 mM thiol sample).[5]
 - Incubate the reaction mixture in the dark at room temperature for 10-15 minutes.[1][2][3]
- **Reaction Quenching:** Stop the reaction by adding an acid, such as methanesulfonic acid, to a final concentration of 25 mM.[3][5]

- Analysis: The resulting fluorescent thiol-bimane adducts can be analyzed by reverse-phase high-performance liquid chromatography (RP-HPLC) with fluorescence detection.[1][2]

Visualizations

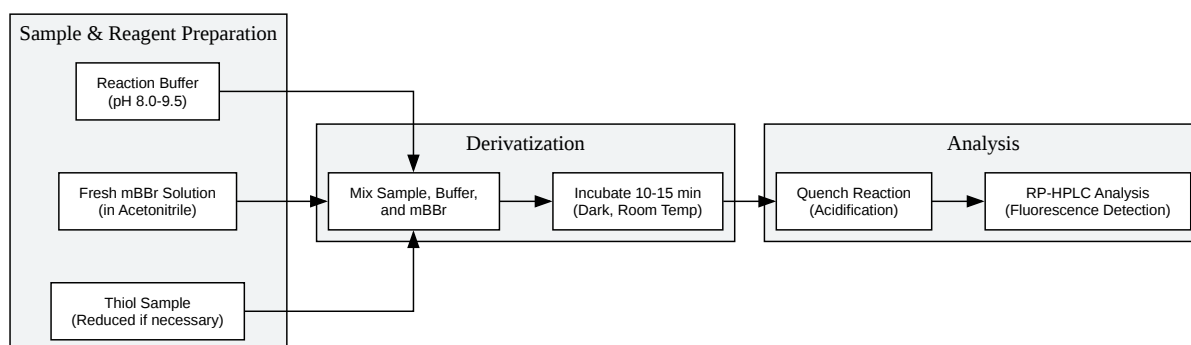

[Click to download full resolution via product page](#)

Caption: Experimental workflow for **bromobimane**-thiol derivatization.

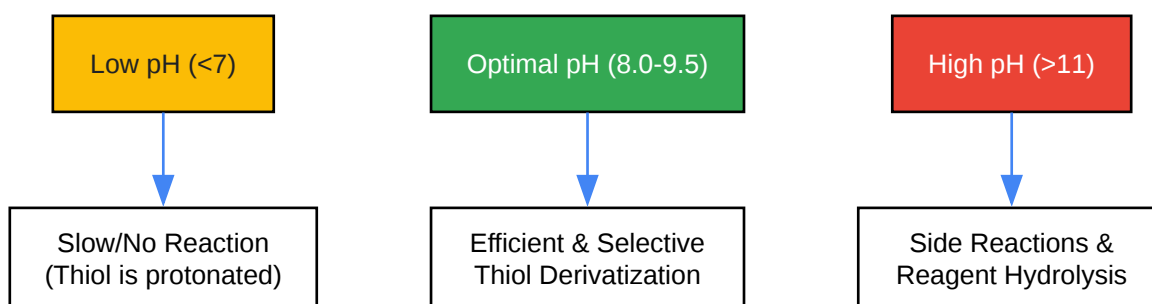

[Click to download full resolution via product page](#)

Need Custom Synthesis?

BenchChem offers custom synthesis for rare earth carbides and specific isotopic labeling.

Email: info@benchchem.com or [Request Quote Online](#).

References

- 1. mdpi.com [mdpi.com]
- 2. pdfs.semanticscholar.org [pdfs.semanticscholar.org]
- 3. Bromobimane | CAS#:71418-44-5 | Chemsrcc [chemsrc.com]
- 4. Methodologies for the application of monobromobimane to the simultaneous analysis of soluble and protein thiol components of biological systems - PubMed [pubmed.ncbi.nlm.nih.gov]
- 5. scispace.com [scispace.com]
- 6. Optimization of a Monobromobimane (MBB) Derivatization and RP-HPLC-FLD Detection Method for Sulfur Species Measurement in Human Serum after Sulfur Inhalation Treatment - PMC [pmc.ncbi.nlm.nih.gov]
- 7. benchchem.com [benchchem.com]
- To cite this document: BenchChem. [Technical Support Center: Bromobimane-Thiol Reactions]. BenchChem, [2025]. [Online PDF]. Available at: [https://www.benchchem.com/product/b013751#impact-of-ph-on-bromobimane-reactivity-with-thiols]

Disclaimer & Data Validity:

The information provided in this document is for Research Use Only (RUO) and is strictly not intended for diagnostic or therapeutic procedures. While BenchChem strives to provide accurate protocols, we make no warranties, express or implied, regarding the fitness of this product for every specific experimental setup.

Technical Support: The protocols provided are for reference purposes. Unsure if this reagent suits your experiment? [[Contact our Ph.D. Support Team for a compatibility check](#)]

Need Industrial/Bulk Grade? [Request Custom Synthesis Quote](#)

BenchChem

Our mission is to be the trusted global source of essential and advanced chemicals, empowering scientists and researchers to drive progress in science and industry.

Contact

Address: 3281 E Guasti Rd

Ontario, CA 91761, United States

Phone: (601) 213-4426

Email: info@benchchem.com