

# Technical Support Center: Antifungal Agent 36 Resistance Studies

**Author:** BenchChem Technical Support Team. **Date:** December 2025

## Compound of Interest

Compound Name: Antifungal agent 36

Cat. No.: B7805992

[Get Quote](#)

This guide provides troubleshooting advice, frequently asked questions (FAQs), and standardized protocols for researchers investigating resistance mechanisms to **Antifungal Agent 36** in fungal pathogens.

## Section 1: Frequently Asked Questions (FAQs)

Q1: What are the primary molecular mechanisms of resistance to **Antifungal Agent 36**?

A1: Resistance to **Antifungal Agent 36**, an azole-class inhibitor, typically involves one or more of the following mechanisms:

- **Overexpression of Efflux Pumps:** The upregulation of genes encoding drug efflux pumps is a common mechanism.<sup>[1][2]</sup> These pumps, belonging to the ATP-Binding Cassette (ABC) transporter superfamily (e.g., CDR1, CDR2) and the Major Facilitator Superfamily (MFS) (e.g., MDR1), actively remove the antifungal agent from the cell, reducing its intracellular concentration.<sup>[1]</sup>
- **Target Enzyme Modification:** Alterations in the target enzyme, lanosterol 14 $\alpha$ -demethylase (encoded by the ERG11 gene), can reduce the binding affinity of the antifungal agent.<sup>[3][4]</sup> This is often due to point mutations in the ERG11 gene.<sup>[2][3]</sup>
- **Target Enzyme Overexpression:** An increase in the production of the Erg11p enzyme, typically through upregulation of the ERG11 gene, can overwhelm the inhibitory capacity of the drug.<sup>[3]</sup>

- Alterations in the Ergosterol Biosynthesis Pathway: Mutations in other genes within the ergosterol pathway (e.g., ERG3) can lead to the accumulation of alternative sterols in the cell membrane, rendering the cell viable even when the primary pathway is inhibited.[3]

Q2: How do I reliably determine if my fungal isolate is resistant to **Antifungal Agent 36**?

A2: The gold standard for determining resistance is through standardized antifungal susceptibility testing (AST) to determine the Minimum Inhibitory Concentration (MIC). The broth microdilution method, following guidelines from the Clinical and Laboratory Standards Institute (CLSI), is the reference method.[5][6][7] An isolate is classified as resistant if its MIC value exceeds the established clinical breakpoint (CBP).[8][9]

Q3: Can an isolate be resistant even if no mutations are found in the ERG11 gene?

A3: Yes. While ERG11 mutations are a key mechanism, resistance is often multifactorial. An isolate with a wild-type ERG11 sequence can still be highly resistant due to the overexpression of efflux pumps (CDR1, MDR1), which effectively reduces the intracellular drug concentration. [1] Therefore, it is crucial to analyze both target gene sequences and the expression levels of relevant efflux pump genes.

## Section 2: Troubleshooting Experimental Issues

Q4: My MIC results are inconsistent across experiments. What are the common causes?

A4: Variability in MIC results is a frequent issue and can often be traced to several factors:

- Inoculum Preparation: The final inoculum concentration is critical. An overly dense inoculum can lead to falsely elevated MICs.[7][10] Always standardize your inoculum using a spectrophotometer or hemocytometer to the recommended concentration (e.g.,  $0.5\text{--}2.5 \times 10^3$  CFU/mL for *Candida* spp. via the CLSI M27 method).
- Incubation Time and Temperature: Deviations from the standard 35°C incubation temperature or inconsistent incubation times (e.g., reading at 24 vs. 48 hours) can significantly alter results.[7][8] For azoles, trailing growth (reduced but persistent growth at concentrations above the MIC) can complicate visual readings at later time points.[10][11]

- Media pH: The activity of azole antifungals is pH-dependent. Ensure your RPMI-1640 medium is properly buffered (typically with MOPS) to a pH of 7.0.
- Endpoint Reading: Subjectivity in visually determining the endpoint (e.g.,  $\geq 50\%$  growth inhibition) is a major source of variability.[12] Using a microplate reader to measure optical density can provide more objective and reproducible results.[7]

Q5: I am not detecting significant overexpression of CDR1 or MDR1 in my confirmed resistant isolate. What other mechanisms should I investigate?

A5: If efflux pump overexpression is not observed, consider the following possibilities:

- Check for ERG11 Mutations: Sequence the ERG11 gene to identify point mutations that may alter the drug target's structure and reduce binding affinity.[2]
- Measure ERG11 Expression: Quantify the expression level of ERG11 itself. Upregulation of the target enzyme is another established resistance mechanism.[3]
- Investigate Other Pathway Genes: Analyze genes upstream and downstream of ERG11 in the ergosterol biosynthesis pathway, such as ERG3. Mutations in these genes can confer resistance.[3]
- Consider Biofilm Formation: If the clinical context involves medical devices, assess the isolate's ability to form biofilms. Biofilm-associated resistance is a complex phenotype that may not correlate with traditional MICs or the mechanisms mentioned above.

## Section 3: Data Presentation

Table 1: Representative MIC Values for **Antifungal Agent 36**

Isolate Type	Strain Example	MIC Range (µg/mL)	Interpretation
<b>Wild-Type Susceptible</b>	<b>C. albicans ATCC 90028</b>	<b>0.25 - 1.0</b>	<b>Susceptible</b>
Resistant (Efflux)	C. albicans 12-99	32 - 128	Resistant
Resistant (ERG11 mut)	C. albicans DSY296	64 - >256	Resistant

| Resistant (Target ↑) | C. albicans 13-81 | 16 - 64 | Resistant |

Note: These values are illustrative. Clinical breakpoints are defined by regulatory bodies like CLSI.[8]

Table 2: Example Gene Expression Changes in Resistant Isolates

Gene	Mechanism	Fold Change vs. Susceptible (Typical Range)
<b>CDR1</b>	<b>Efflux Pump (ABC)</b>	<b>5 to 50-fold increase</b>
MDR1	Efflux Pump (MFS)	2 to 20-fold increase

| ERG11 | Target Enzyme | 2 to 10-fold increase |

## Section 4: Experimental Protocols

### Protocol 1: Broth Microdilution MIC Assay (CLSI M27-Based)

- Prepare Drug Plate: Serially dilute **Antifungal Agent 36** in RPMI-1640 medium across a 96-well plate to achieve a 2x final concentration range (e.g., 0.25 to 256 µg/mL). Include a drug-free well for a growth control and a media-only well for a sterility control.
- Prepare Inoculum: From a fresh (24-hour) culture on Sabouraud Dextrose Agar, suspend colonies in sterile saline. Adjust the suspension to a 0.5 McFarland standard (approx. 1-5 x

$10^6$  CFU/mL).

- Dilute Inoculum: Dilute the standardized suspension 1:1000 in RPMI-1640 medium to obtain the final working inoculum of  $1-5 \times 10^3$  CFU/mL.
- Inoculate Plate: Add 100  $\mu$ L of the working inoculum to each well of the drug plate. The final volume will be 200  $\mu$ L per well, and the drug concentrations will be at 1x.
- Incubate: Cover the plate and incubate at 35°C for 24 to 48 hours.
- Determine MIC: The MIC is the lowest drug concentration that causes at least a 50% reduction in growth compared to the drug-free control well. This can be assessed visually or by reading the optical density at 490 nm.[7]

## Protocol 2: qRT-PCR for Gene Expression Analysis

- Culture and RNA Extraction: Grow susceptible and resistant isolates in a suitable broth medium (e.g., YPD) to mid-log phase. Optionally, expose cells to a sub-inhibitory concentration of **Antifungal Agent 36** to induce gene expression. Harvest cells and extract total RNA using a reliable method (e.g., hot phenol or a commercial kit).[13]
- DNase Treatment: Treat the extracted RNA with DNase I to remove any contaminating genomic DNA.
- cDNA Synthesis: Synthesize first-strand cDNA from 1-2  $\mu$ g of total RNA using a reverse transcriptase enzyme and random hexamer or oligo(dT) primers.[14]
- qPCR Reaction: Set up the qPCR reaction using a suitable master mix (e.g., SYBR Green or TaqMan), cDNA template, and gene-specific primers for your target genes (CDR1, MDR1, ERG11) and a validated housekeeping gene (ACT1, PMA1).[15]
- Thermal Cycling: Run the reaction on a real-time PCR instrument with a standard cycling protocol (e.g., 95°C for 10 min, followed by 40 cycles of 95°C for 15s and 60°C for 1 min).
- Data Analysis: Calculate the relative expression of target genes using the  $\Delta\Delta C_t$  method. Normalize the  $C_t$  value of your target gene to the  $C_t$  value of the housekeeping gene. Then, compare the normalized expression in the resistant strain to that of the susceptible control strain to determine the fold change.

## Section 5: Visualizations

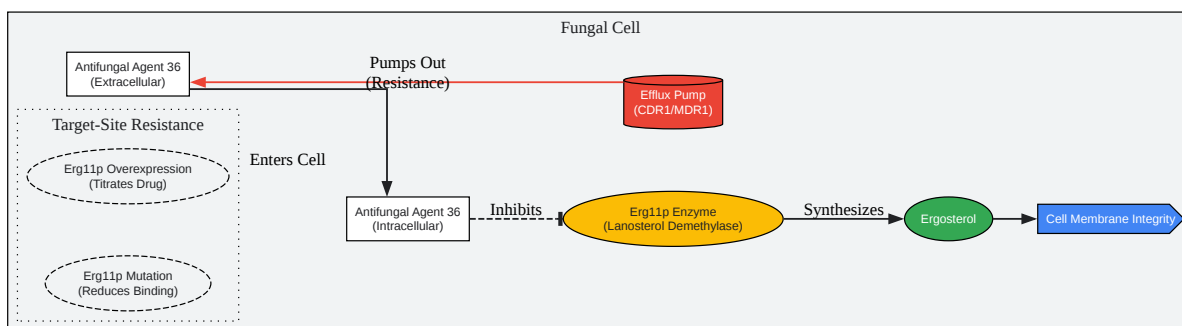

[Click to download full resolution via product page](#)

Caption: Key molecular mechanisms of resistance to azole-class antifungal agents.

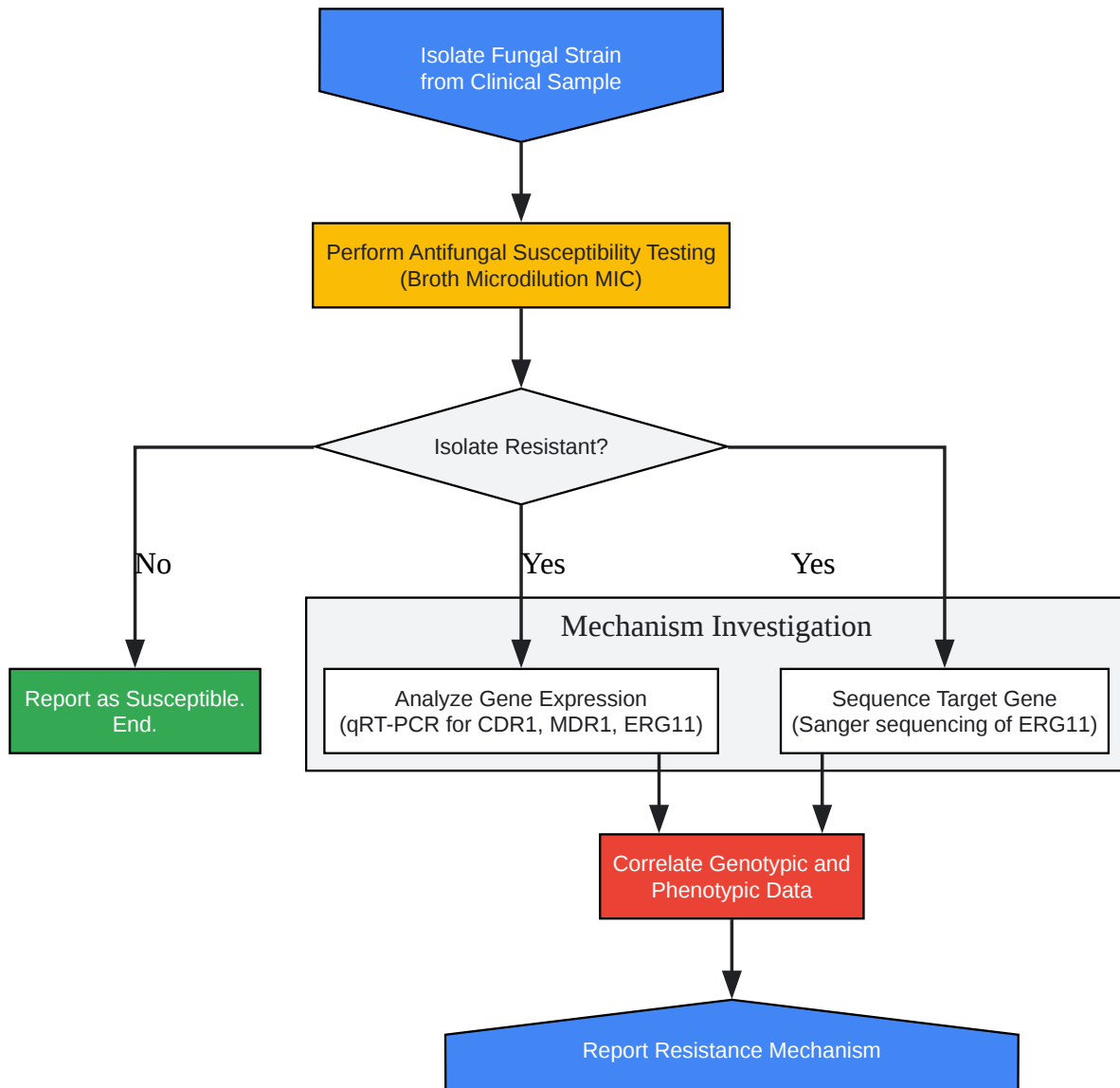

[Click to download full resolution via product page](#)

Caption: Workflow for identifying and characterizing antifungal resistance.

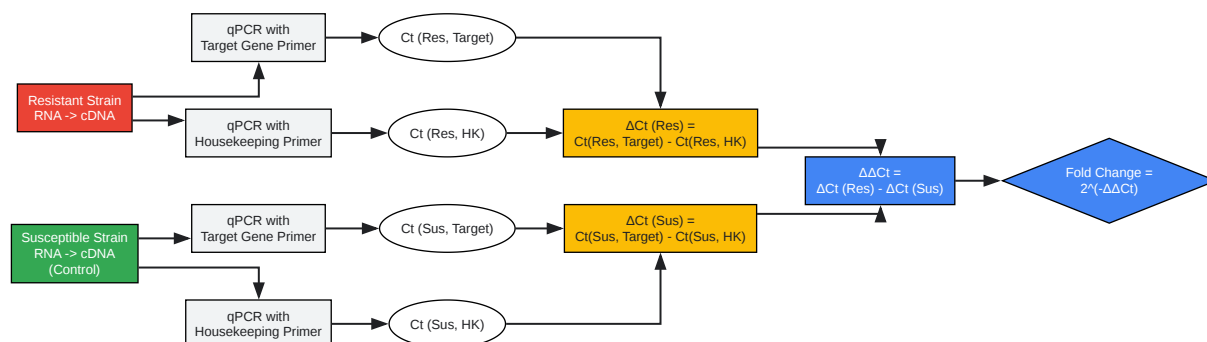

[Click to download full resolution via product page](#)

### Need Custom Synthesis?

BenchChem offers custom synthesis for rare earth carbides and specific isotopic labeling.

Email: [info@benchchem.com](mailto:info@benchchem.com) or [Request Quote Online](#).

## References

- 1. academic.oup.com [academic.oup.com]
- 2. dovepress.com [dovepress.com]
- 3. thecandidadiet.com [thecandidadiet.com]
- 4. researchgate.net [researchgate.net]
- 5. M07 | Methods for Dilution Antimicrobial Susceptibility Tests for Bacteria That Grow Aerobically [clsi.org]
- 6. Evaluation of CLSI Agar Dilution Method and Trek Sensititre Broth Microdilution Panel for Determining Antimicrobial Susceptibility of Streptococcus pneumoniae - PMC [pmc.ncbi.nlm.nih.gov]
- 7. benchchem.com [benchchem.com]



- 8. academic.oup.com [academic.oup.com]
- 9. A Practical Guide to Antifungal Susceptibility Testing - PMC [pmc.ncbi.nlm.nih.gov]
- 10. Antifungal Susceptibility Testing: Practical Aspects and Current Challenges - PMC [pmc.ncbi.nlm.nih.gov]
- 11. Can We Improve Antifungal Susceptibility Testing? - PMC [pmc.ncbi.nlm.nih.gov]
- 12. academic.oup.com [academic.oup.com]
- 13. academic.oup.com [academic.oup.com]
- 14. iem.modares.ac.ir [iem.modares.ac.ir]
- 15. Development and evaluation of different normalization strategies for gene expression studies in Candida albicans biofilms by real-time PCR - PMC [pmc.ncbi.nlm.nih.gov]
- To cite this document: BenchChem. [Technical Support Center: Antifungal Agent 36 Resistance Studies]. BenchChem, [2025]. [Online PDF]. Available at: [https://www.benchchem.com/product/b7805992#antifungal-agent-36-resistance-mechanism-studies]

---

#### Disclaimer & Data Validity:

The information provided in this document is for Research Use Only (RUO) and is strictly not intended for diagnostic or therapeutic procedures. While BenchChem strives to provide accurate protocols, we make no warranties, express or implied, regarding the fitness of this product for every specific experimental setup.

**Technical Support:** The protocols provided are for reference purposes. Unsure if this reagent suits your experiment? [[Contact our Ph.D. Support Team for a compatibility check](#)]

**Need Industrial/Bulk Grade?** [Request Custom Synthesis Quote](#)

## BenchChem

Our mission is to be the trusted global source of essential and advanced chemicals, empowering scientists and researchers to drive progress in science and industry.

#### Contact

Address: 3281 E Guasti Rd  
Ontario, CA 91761, United States  
Phone: (601) 213-4426  
Email: [info@benchchem.com](mailto:info@benchchem.com)

