

# Technical Support Center: Anlotinib in Cell Culture

**Author:** BenchChem Technical Support Team. **Date:** December 2025

## Compound of Interest

Compound Name: Anlotinib (hydrochloride)

Cat. No.: B10783339

[Get Quote](#)

For Researchers, Scientists, and Drug Development Professionals

This technical support center provides comprehensive guidance on the use of anlotinib in cell culture experiments, with a specific focus on addressing the common issue of its precipitation in aqueous media.

## Frequently Asked Questions (FAQs)

Q1: I observed a precipitate in my cell culture medium after adding anlotinib. What are the common causes?

A1: Anlotinib precipitation in cell culture media is a common issue primarily due to its low aqueous solubility. Several factors can contribute to this:

- **Exceeding Solubility Limit:** The final concentration of anlotinib in your culture medium may be higher than its solubility limit in that specific medium.
- **"Solvent Shock":** Anlotinib is typically dissolved in an organic solvent like DMSO to create a stock solution. Rapidly diluting this concentrated stock into the aqueous cell culture medium can cause the drug to crash out of solution.
- **Improper Dilution Technique:** Adding the anlotinib stock solution directly to the full volume of media without proper mixing can lead to localized high concentrations and precipitation.

- **Low Temperature of Media:** Adding the anlotinib stock to cold media can decrease its solubility and promote precipitation.
- **Interaction with Media Components:** Although less common, interactions with salts, proteins, or other components in the culture medium could potentially reduce anlotinib's solubility.

Q2: What is the recommended solvent for preparing anlotinib stock solutions?

A2: Dimethyl sulfoxide (DMSO) is the most recommended solvent for preparing anlotinib stock solutions for in vitro studies.[1][2][3][4] It is crucial to use anhydrous, high-purity DMSO to ensure the stability of the compound.

Q3: What is a safe concentration of DMSO for my cells?

A3: The final concentration of DMSO in the cell culture medium should be kept as low as possible to avoid solvent-induced cytotoxicity. A final DMSO concentration of less than 0.5% (v/v) is generally considered safe for most cell lines.[5] However, the tolerance to DMSO can be cell-line specific. It is always recommended to include a vehicle control (media with the same final concentration of DMSO without anlotinib) in your experiments to assess any potential effects of the solvent on your cells.

Q4: Can I store anlotinib in a diluted aqueous solution?

A4: It is not recommended to store anlotinib in aqueous solutions for more than one day.[1] For optimal stability, prepare fresh dilutions from your DMSO stock solution for each experiment.

## Troubleshooting Guide: Anlotinib Precipitation

This guide provides a step-by-step approach to troubleshoot and prevent anlotinib precipitation in your cell culture experiments.

### Problem: Precipitate Forms Immediately Upon Adding Anlotinib to Cell Culture Media

Possible Cause	Solution
"Solvent Shock"	Instead of adding the concentrated DMSO stock directly to the full volume of media, perform a serial dilution. First, dilute the stock solution in a small volume of pre-warmed (37°C) cell culture medium. Then, add this intermediate dilution to the final volume of your medium. Adding the compound dropwise while gently vortexing can also aid in dispersion.
High Final Concentration	Start with a lower final concentration of anlotinib and gradually increase it to determine the highest concentration that remains in solution in your specific cell culture medium.
Cold Media	Always use pre-warmed (37°C) cell culture medium for preparing your final working solutions.

## **Problem: Precipitate Forms Over Time in the Incubator**

Possible Cause	Solution
Concentration Exceeds Long-Term Solubility	The final concentration may be at the border of its solubility and precipitates out over time due to temperature fluctuations or interactions with cellular metabolites. Try using a slightly lower final concentration.
Instability in Media	While anlotinib is generally stable, prolonged incubation in certain media compositions could lead to degradation and precipitation. If this is suspected, consider reducing the incubation time if experimentally feasible.

## **Quantitative Data Summary**

The following table summarizes the solubility of anlotinib in various solvents.

Solvent	Approximate Solubility	Source(s)
DMSO	~1 mg/mL	[6]
~48 mg/mL (99.92 mM)	[7]	
~96 mg/mL (199.85 mM)	[7]	
Dimethylformamide (DMF)	~0.5 mg/mL	[6]
DMSO:PBS (pH 7.2) (1:3)	~0.25 mg/mL	[6]

Note: The solubility of anlotinib can be affected by the purity of the compound, the grade of the solvent, temperature, and pH. The provided values should be used as a guideline.

## Experimental Protocols

### Protocol 1: Preparation of Anlotinib Stock and Working Solutions

This protocol provides a detailed methodology for preparing anlotinib solutions for cell culture experiments to minimize the risk of precipitation.

Materials:

- Anlotinib hydrochloride (solid)
- Anhydrous, sterile DMSO
- Sterile, pre-warmed (37°C) complete cell culture medium
- Sterile microcentrifuge tubes

Methodology:

- Stock Solution Preparation (e.g., 10 mM in DMSO):
  - Calculate the required amount of anlotinib hydrochloride based on its molecular weight (443.9 g/mol).

- In a sterile environment, dissolve the calculated amount of anlotinib in the appropriate volume of sterile DMSO to achieve a 10 mM stock solution.
- Vortex thoroughly until the compound is completely dissolved.
- Aliquot the stock solution into smaller volumes in sterile microcentrifuge tubes to avoid repeated freeze-thaw cycles.
- Store the aliquots at -20°C, protected from light.
- Working Solution Preparation (e.g., 10 µM in cell culture medium):
  - Thaw an aliquot of the 10 mM anlotinib stock solution at room temperature.
  - Stepwise Dilution:
    - Prepare an intermediate dilution by adding a small volume of the stock solution to pre-warmed (37°C) complete cell culture medium. For example, to prepare a 100 µM intermediate solution, add 1 µL of the 10 mM stock to 99 µL of media. Mix gently by pipetting.
    - Add the required volume of the intermediate dilution to your final volume of pre-warmed cell culture medium to achieve the desired final concentration (e.g., 10 µL of 100 µM intermediate solution to 990 µL of media for a final concentration of 1 µM).
  - Gently mix the final working solution before adding it to your cells.
  - Important: Always prepare fresh working solutions for each experiment. Do not store diluted anlotinib in cell culture medium.

## Protocol 2: Determining the Maximum Soluble Concentration of Anlotinib in Your Cell Culture Medium

This protocol helps you determine the empirical solubility limit of anlotinib in your specific experimental conditions.

Methodology:

- Prepare a series of dilutions of your anlotinib DMSO stock solution in your complete cell culture medium in sterile, clear microcentrifuge tubes. For example, prepare final concentrations ranging from 1  $\mu\text{M}$  to 50  $\mu\text{M}$ . Ensure the final DMSO concentration is constant and below 0.5% across all dilutions.
- Include a vehicle control tube containing only the cell culture medium with the same final DMSO concentration.
- Incubate the tubes under your standard cell culture conditions (e.g., 37°C, 5% CO<sub>2</sub>) for the duration of your planned experiment (e.g., 24, 48, or 72 hours).
- Visually inspect each tube for any signs of precipitation (cloudiness, visible particles) against a dark background at different time points.
- The highest concentration that remains clear throughout the incubation period is your maximum working concentration under those conditions.

## Visualizations

### Signaling Pathways Inhibited by Anlotinib

Anlotinib is a multi-target tyrosine kinase inhibitor that primarily targets key signaling pathways involved in angiogenesis and tumor cell proliferation.

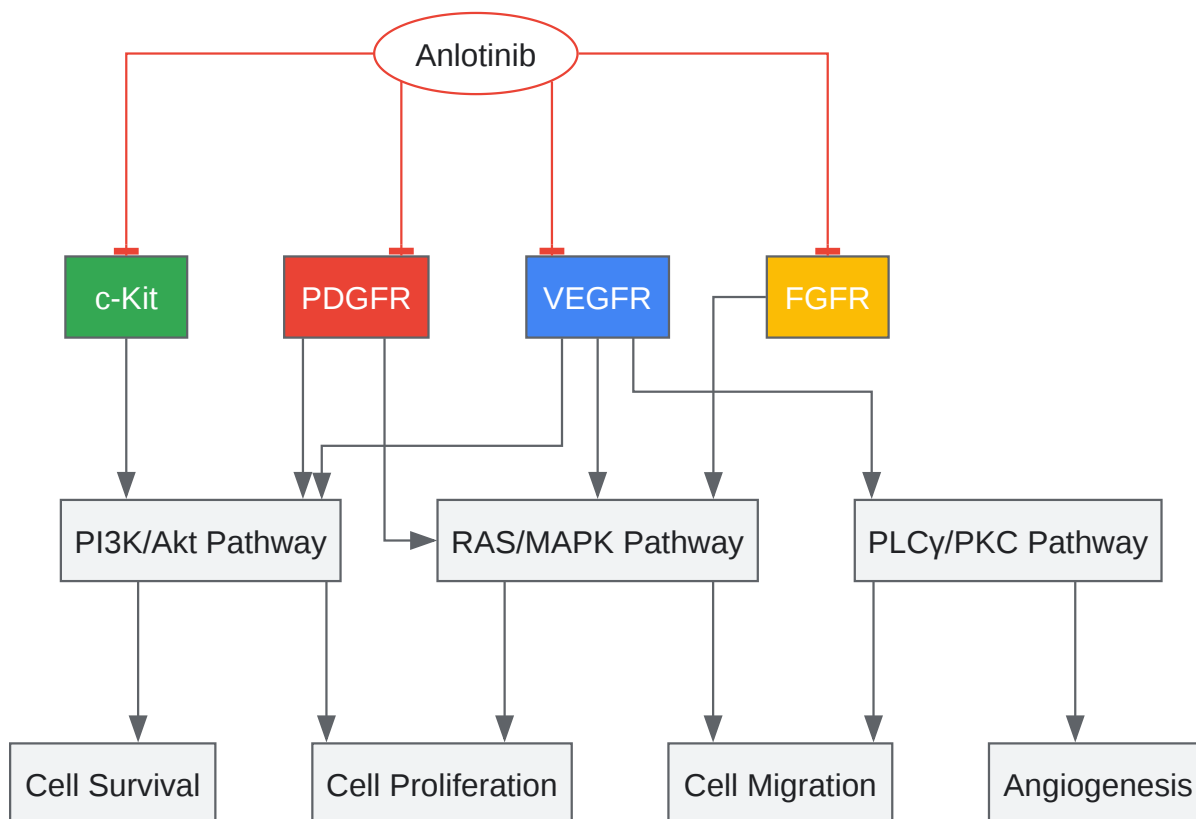

[Click to download full resolution via product page](#)

Caption: Anlotinib inhibits multiple receptor tyrosine kinases.

## Experimental Workflow for Troubleshooting Anlotinib Precipitation

This workflow provides a logical sequence of steps to address precipitation issues.

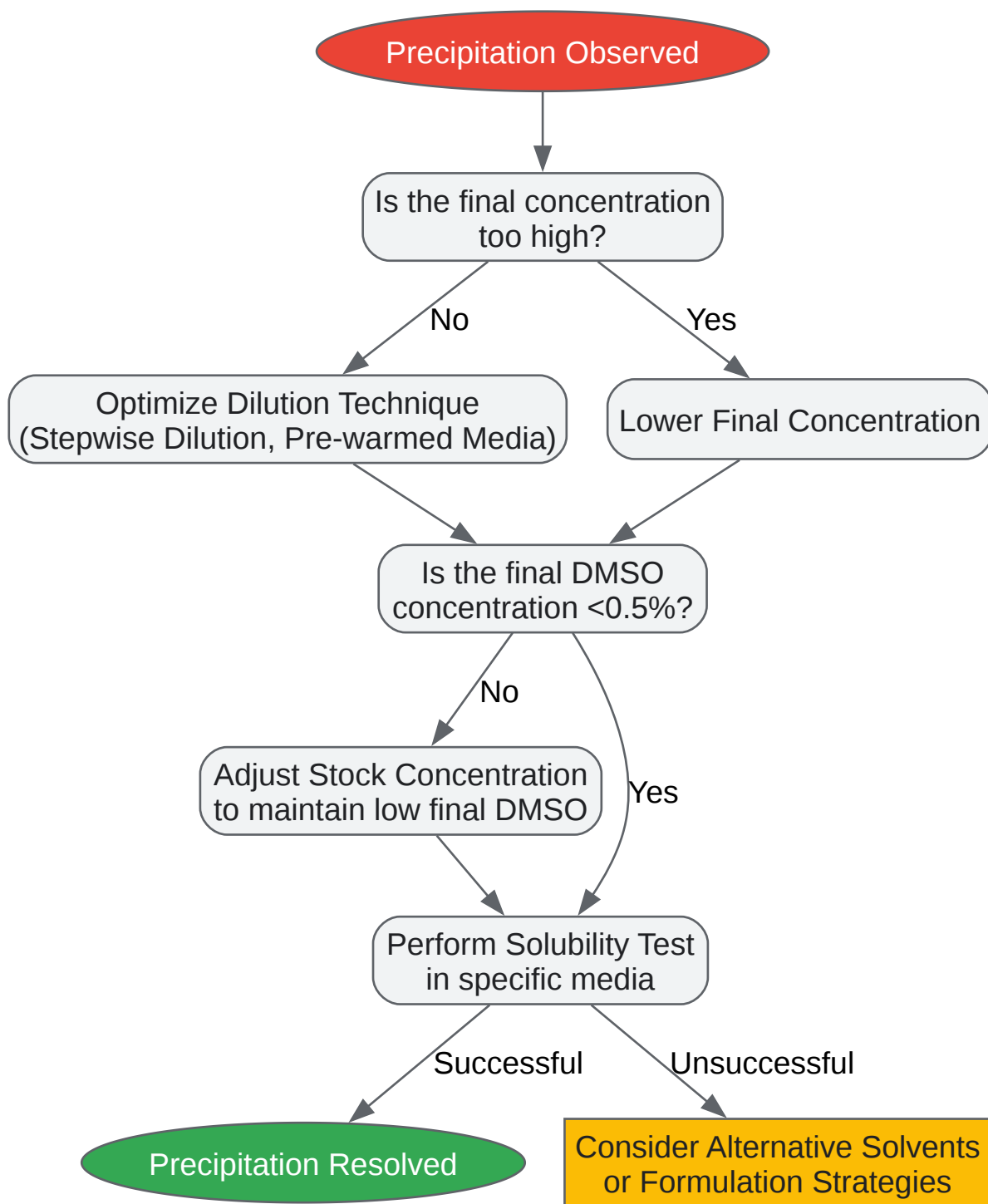

[Click to download full resolution via product page](#)

Caption: Troubleshooting workflow for anlotinib precipitation.



### Need Custom Synthesis?

BenchChem offers custom synthesis for rare earth carbides and specific isotopic labeling.

Email: [info@benchchem.com](mailto:info@benchchem.com) or [Request Quote Online](#).

## References

- 1. [cdn.caymanchem.com](http://cdn.caymanchem.com) [[cdn.caymanchem.com](http://cdn.caymanchem.com)]
- 2. Anlotinib exerts potent antileukemic activities in Ph chromosome negative and positive B-cell acute lymphoblastic leukemia via perturbation of PI3K/AKT/mTOR pathway - PMC [[pmc.ncbi.nlm.nih.gov](http://pmc.ncbi.nlm.nih.gov)]
- 3. Anlotinib combined with gefitinib can significantly improve the proliferation of epidermal growth factor receptor-mutant advanced non-small cell lung cancer in vitro and in vivo - PMC [[pmc.ncbi.nlm.nih.gov](http://pmc.ncbi.nlm.nih.gov)]
- 4. Anlotinib suppresses MLL-rearranged acute myeloid leukemia cell growth by inhibiting SETD1A/AKT-mediated DNA damage response - PMC [[pmc.ncbi.nlm.nih.gov](http://pmc.ncbi.nlm.nih.gov)]
- 5. [lifetein.com](http://lifetein.com) [[lifetein.com](http://lifetein.com)]
- 6. [caymanchem.com](http://caymanchem.com) [[caymanchem.com](http://caymanchem.com)]
- 7. [selleckchem.com](http://selleckchem.com) [[selleckchem.com](http://selleckchem.com)]
- To cite this document: BenchChem. [Technical Support Center: Anlotinib in Cell Culture]. BenchChem, [2025]. [Online PDF]. Available at: [<https://www.benchchem.com/product/b10783339#anlotinib-precipitation-in-cell-culture-media>]

---

### Disclaimer & Data Validity:

The information provided in this document is for Research Use Only (RUO) and is strictly not intended for diagnostic or therapeutic procedures. While BenchChem strives to provide accurate protocols, we make no warranties, express or implied, regarding the fitness of this product for every specific experimental setup.

**Technical Support:** The protocols provided are for reference purposes. Unsure if this reagent suits your experiment? [[Contact our Ph.D. Support Team for a compatibility check](#)]

**Need Industrial/Bulk Grade?** [Request Custom Synthesis Quote](#)

## BenchChem

Our mission is to be the trusted global source of essential and advanced chemicals, empowering scientists and researchers to drive progress in science and industry.

### Contact

Address: 3281 E Guasti Rd  
Ontario, CA 91761, United States  
Phone: (601) 213-4426  
Email: [info@benchchem.com](mailto:info@benchchem.com)