

# Technical Support Center: Addressing GW7845 Resistance in Cell Lines

**Author:** BenchChem Technical Support Team. **Date:** December 2025

## Compound of Interest

Compound Name: GW7845

Cat. No.: B1672479

[Get Quote](#)

This technical support center provides troubleshooting guides and frequently asked questions (FAQs) for researchers, scientists, and drug development professionals encountering resistance to the non-thiazolidinedione PPAR $\gamma$  agonist, **GW7845**, in cell lines.

## Frequently Asked Questions (FAQs)

Q1: What is **GW7845** and what is its primary mechanism of action?

**GW7845** is a potent and selective agonist for the Peroxisome Proliferator-Activated Receptor gamma (PPAR $\gamma$ ), a nuclear receptor that functions as a transcription factor. Upon binding to **GW7845**, PPAR $\gamma$  forms a heterodimer with the Retinoid X Receptor (RXR). This complex then binds to specific DNA sequences known as Peroxisome Proliferator Response Elements (PPREs) in the promoter region of target genes, leading to the regulation of their transcription. This regulation affects various cellular processes including cell proliferation, differentiation, and apoptosis.

Q2: In which cancer cell lines has **GW7845** shown activity?

While specific IC<sub>50</sub> values for **GW7845** are not widely reported in publicly available literature, PPAR $\gamma$  agonists, in general, have been shown to inhibit the growth of various cancer cell lines. The sensitivity to **GW7845** can vary significantly between cell lines. It is crucial to determine the half-maximal inhibitory concentration (IC<sub>50</sub>) for your specific cell line of interest through a dose-response experiment.

Q3: What are the potential mechanisms of resistance to PPAR $\gamma$  agonists like **GW7845**?

While specific resistance mechanisms to **GW7845** have not been extensively characterized, resistance to PPAR $\gamma$  agonists can arise from several factors, including:

- Alterations in the PPAR $\gamma$  receptor: Mutations in the PPARG gene can lead to a receptor that no longer binds to the agonist or is unable to effectively regulate gene transcription.
- Changes in co-regulator proteins: The transcriptional activity of PPAR $\gamma$  is dependent on the recruitment of co-activator and co-repressor proteins. Altered expression or function of these co-regulators can diminish the cellular response to a PPAR $\gamma$  agonist.
- Activation of alternative signaling pathways: Cancer cells can develop resistance by upregulating pro-survival signaling pathways that bypass the effects of PPAR $\gamma$  activation. The Mitogen-Activated Protein Kinase (MAPK) pathways, such as p38 MAPK and JNK, have been implicated in both the pro-apoptotic effects of **GW7845** and in mechanisms of drug resistance in general.[\[1\]](#)[\[2\]](#)[\[3\]](#)[\[4\]](#)[\[5\]](#)[\[6\]](#)[\[7\]](#)[\[8\]](#)[\[9\]](#)[\[10\]](#)
- Increased drug efflux: Overexpression of ATP-binding cassette (ABC) transporters, such as ABCG2, can actively pump the drug out of the cell, reducing its intracellular concentration and efficacy.[\[1\]](#)[\[2\]](#)[\[11\]](#)[\[12\]](#)[\[13\]](#)
- Altered drug metabolism: Cells may develop mechanisms to metabolize and inactivate the drug more efficiently.[\[14\]](#)[\[15\]](#)[\[16\]](#)[\[17\]](#)[\[18\]](#)[\[19\]](#)

Q4: How can I determine if my cell line has developed resistance to **GW7845**?

The most direct way to confirm resistance is to perform a cell viability assay (e.g., MTT, XTT, or resazurin assay) to determine the IC<sub>50</sub> of **GW7845** in your suspected resistant cell line and compare it to the parental, sensitive cell line. A significant increase (typically 3-fold or higher) in the IC<sub>50</sub> value is a strong indicator of acquired resistance.

## Troubleshooting Guides

### Problem 1: My cell line is not responding to **GW7845** treatment as expected (no decrease in cell viability).

Possible Cause	Troubleshooting Steps
Suboptimal Drug Concentration	Determine the IC50 of GW7845 for your specific parental cell line using a dose-response curve. Ensure you are using a concentration range that brackets the expected IC50.
Drug Instability	Prepare fresh stock solutions of GW7845 and dilute to the final working concentration immediately before use. Avoid repeated freeze-thaw cycles.
Cell Line Misidentification or Contamination	Authenticate your cell line using short tandem repeat (STR) profiling. Regularly test for mycoplasma contamination.
Intrinsic Resistance	The cell line may have inherent resistance to PPAR $\gamma$ agonists. Consider screening a panel of different cell lines to find a sensitive model.

## Problem 2: My cell line has developed resistance to GW7845 after prolonged treatment.

Possible Cause	Investigative Steps
Altered PPAR $\gamma$ Expression or Function	<ul style="list-style-type: none"> <li>- qPCR: Compare PPAR<math>\gamma</math> mRNA levels between sensitive and resistant cells.</li> <li>- Western Blot: Compare PPAR<math>\gamma</math> protein levels.</li> <li>- Sanger Sequencing: Sequence the PPAR<math>\gamma</math> gene in resistant cells to identify potential mutations.</li> </ul>
Activation of Bypass Signaling Pathways	<ul style="list-style-type: none"> <li>- Western Blot: Analyze the phosphorylation status of key proteins in survival pathways, such as Akt, and MAPK pathways (p-p38, p-JNK). Increased phosphorylation in resistant cells may indicate pathway activation.</li> </ul>
Increased Drug Efflux	<ul style="list-style-type: none"> <li>- qPCR: Measure the mRNA levels of common drug efflux pump genes (e.g., ABCG2, ABCB1).</li> <li>- Western Blot: Analyze the protein levels of the corresponding transporters.</li> <li>- Functional Assay: Use a fluorescent substrate of the suspected transporter (e.g., pheophorbide A for ABCG2) with and without a known inhibitor to assess efflux activity.</li> </ul>
Altered Drug Metabolism	<ul style="list-style-type: none"> <li>- This is more complex to analyze and may require metabolomics studies to identify potential drug metabolites.</li> </ul>

## Data Presentation

Table 1: Example IC<sub>50</sub> Values of Various Anticancer Drugs in Common Cancer Cell Lines ( $\mu$ M)

Note: Specific IC<sub>50</sub> values for **GW7845** are not readily available in the public domain. The data below is for other compounds and serves as a template for how to present your own experimental data.

Cell Line	Drug 1 (e.g., Doxorubicin)	Drug 2 (e.g., Paclitaxel)	Drug 3 (e.g., Cisplatin)
MCF-7 (Breast Cancer)	0.05 - 1.0[7][14][16][20][21][22]	0.002 - 0.1[20]	5 - 30[23]
HT-29 (Colon Cancer)	0.1 - 2.0[9][21][23][24][25][26][27][28]	0.005 - 0.5[26]	10 - 50[26]
PC-3 (Prostate Cancer)	0.1 - 1.5[13][26][29][30][31][32][33][34][35]	0.001 - 0.05[26]	2 - 20[13][30]
A549 (Lung Cancer)	0.02 - 0.5[4][12][24][29][36][37][38][39]	0.001 - 0.02[37]	5 - 25[4][37]

## Experimental Protocols

### Cell Viability Assay (MTT Assay)

This protocol is for determining the IC<sub>50</sub> of **GW7845**.

- Cell Seeding: Seed cells in a 96-well plate at a density of 5,000-10,000 cells/well and allow them to adhere overnight.
- Drug Treatment: Prepare serial dilutions of **GW7845** in culture medium. Replace the medium in the wells with the drug-containing medium. Include a vehicle control (e.g., DMSO).
- Incubation: Incubate the plate for 24, 48, or 72 hours.
- MTT Addition: Add 20  $\mu$ L of MTT solution (5 mg/mL in PBS) to each well and incubate for 3-4 hours at 37°C.
- Formazan Solubilization: Remove the medium and add 150  $\mu$ L of DMSO to each well to dissolve the formazan crystals.
- Absorbance Measurement: Measure the absorbance at 570 nm using a microplate reader.
- Data Analysis: Calculate the percentage of cell viability relative to the vehicle control and plot a dose-response curve to determine the IC<sub>50</sub> value.

## Western Blot for Signaling Pathway Analysis

This protocol is to assess the activation of MAPK pathways.

- **Cell Lysis:** Treat sensitive and resistant cells with **GW7845** for various time points. Lyse the cells in RIPA buffer containing protease and phosphatase inhibitors.
- **Protein Quantification:** Determine the protein concentration of the lysates using a BCA assay.
- **SDS-PAGE:** Load equal amounts of protein (20-30 µg) onto an SDS-polyacrylamide gel and perform electrophoresis.
- **Protein Transfer:** Transfer the separated proteins to a PVDF membrane.
- **Blocking:** Block the membrane with 5% non-fat milk or BSA in TBST for 1 hour at room temperature.
- **Primary Antibody Incubation:** Incubate the membrane with primary antibodies against total and phosphorylated forms of p38 MAPK and JNK overnight at 4°C.
- **Secondary Antibody Incubation:** Wash the membrane and incubate with HRP-conjugated secondary antibodies for 1 hour at room temperature.
- **Detection:** Visualize the protein bands using an enhanced chemiluminescence (ECL) substrate and an imaging system.
- **Analysis:** Quantify the band intensities and normalize the phosphorylated protein levels to the total protein levels.

## Quantitative Real-Time PCR (qPCR) for Gene Expression Analysis

This protocol is for measuring the expression of PPAR $\gamma$  and drug efflux pump genes.

- **RNA Extraction:** Extract total RNA from sensitive and resistant cells using a suitable kit.
- **cDNA Synthesis:** Synthesize cDNA from the extracted RNA using a reverse transcription kit.

- qPCR Reaction: Set up the qPCR reaction using SYBR Green master mix, cDNA template, and primers specific for PPARG, ABCG2, and a housekeeping gene (e.g., GAPDH or ACTB).
- Thermal Cycling: Perform the qPCR reaction in a real-time PCR system.
- Data Analysis: Calculate the relative gene expression using the  $\Delta\Delta C_t$  method, normalizing the expression of the target genes to the housekeeping gene.

## Mandatory Visualization

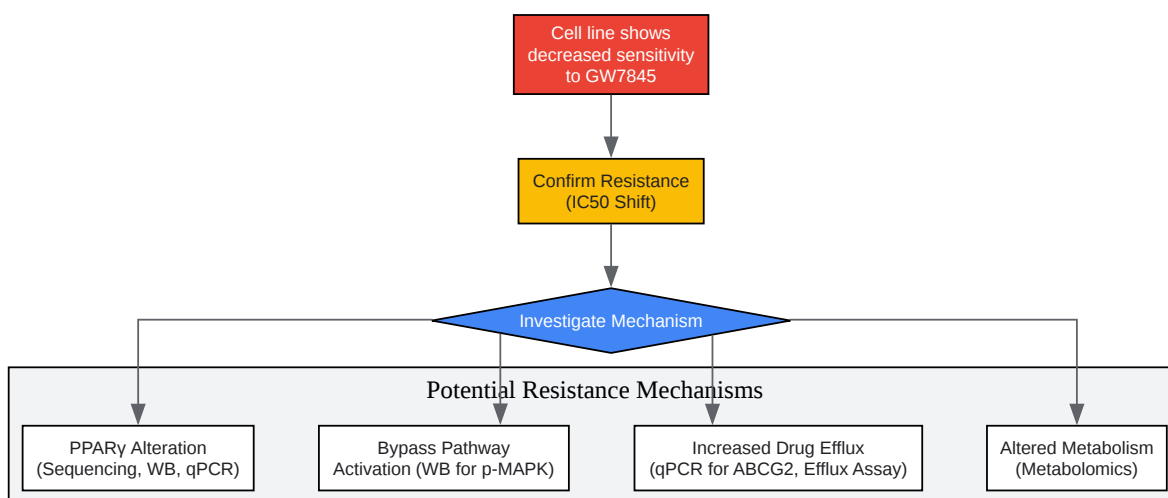
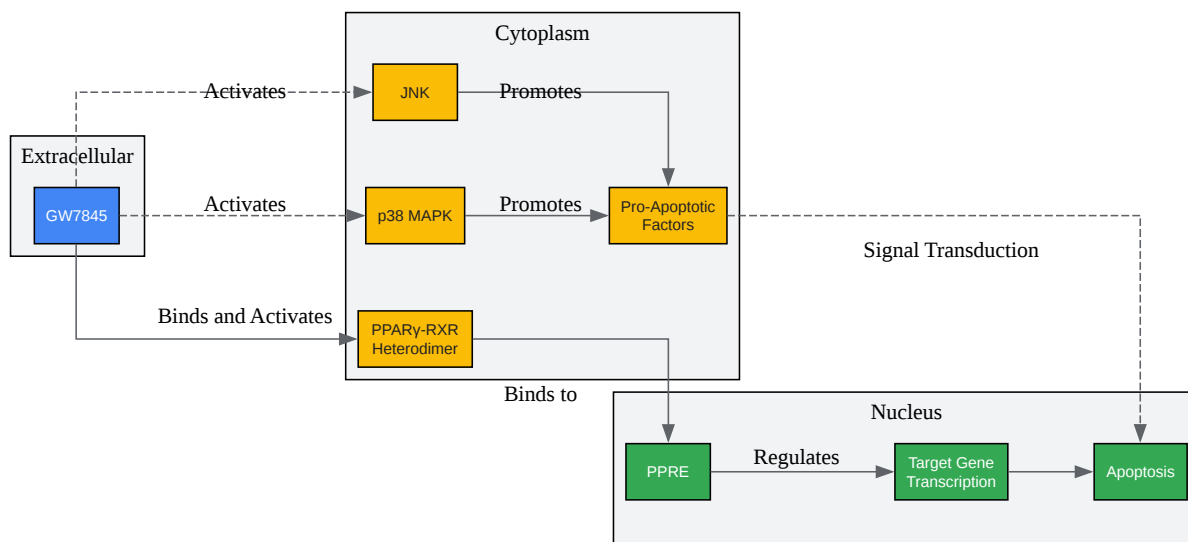



[Click to download full resolution via product page](#)

### Need Custom Synthesis?

BenchChem offers custom synthesis for rare earth carbides and specific isotopic labeling.

Email: [info@benchchem.com](mailto:info@benchchem.com) or [Request Quote Online](#).

## References

- 1. researchgate.net [researchgate.net]
- 2. Repression of PPAR $\gamma$  reduces the ABCG2-mediated efflux activity of M2 macrophages - PubMed [pubmed.ncbi.nlm.nih.gov]
- 3. researchgate.net [researchgate.net]
- 4. RESISTANCE TO PLATINUM-BASED CHEMOTHERAPY IN LUNG CANCER CELL LINES - PMC [pmc.ncbi.nlm.nih.gov]
- 5. Peroxisome proliferator-activated receptors: Key regulators of tumor progression and growth - PMC [pmc.ncbi.nlm.nih.gov]
- 6. researchgate.net [researchgate.net]
- 7. PPAR-gamma agonists inhibit toll-like receptor-mediated activation of dendritic cells via the MAP kinase and NF-kappaB pathways - PubMed [pubmed.ncbi.nlm.nih.gov]
- 8. Antidiabetic thiazolidinediones inhibit invasiveness of pancreatic cancer cells via PPAR $\gamma$  independent mechanisms - PMC [pmc.ncbi.nlm.nih.gov]
- 9. mdpi.com [mdpi.com]
- 10. PPAR- $\gamma$  Agonists As Antineoplastic Agents in Cancers with Dysregulated IGF Axis - PMC [pmc.ncbi.nlm.nih.gov]
- 11. Targeting the ABCG2-overexpressing multidrug resistant (MDR) cancer cells by PPAR $\gamma$  agonists - PMC [pmc.ncbi.nlm.nih.gov]
- 12. Targeting the ABCG2-overexpressing multidrug resistant (MDR) cancer cells by PPAR $\gamma$  agonists - PubMed [pubmed.ncbi.nlm.nih.gov]
- 13. Multidrug efflux transporter ABCG2: expression and regulation - PMC [pmc.ncbi.nlm.nih.gov]
- 14. researchgate.net [researchgate.net]
- 15. aacrjournals.org [aacrjournals.org]

- 16. [mdpi.com](#) [[mdpi.com](#)]
- 17. PPAR $\gamma$  deacetylation dissociates thiazolidinedione's metabolic benefits from its adverse effects - PMC [[pmc.ncbi.nlm.nih.gov](#)]
- 18. PPAR $\gamma$  signaling and metabolism: the good, the bad and the future - PMC [[pmc.ncbi.nlm.nih.gov](#)]
- 19. Re-highlighting the action of PPAR $\gamma$  in treating metabolic diseases - PMC [[pmc.ncbi.nlm.nih.gov](#)]
- 20. Cytotoxicity of synthetic derivatives against breast cancer and multi-drug resistant breast cancer cell lines: a literature-based perspective study - PMC [[pmc.ncbi.nlm.nih.gov](#)]
- 21. In vitro Cytotoxicity and Apoptotic Assay in HT-29 Cell Line Using Ficus hispida Linn: Leaves Extract - PMC [[pmc.ncbi.nlm.nih.gov](#)]
- 22. Inhibition of human breast cancer cell proliferation with estradiol metabolites is as effective as with tamoxifen - PubMed [[pubmed.ncbi.nlm.nih.gov](#)]
- 23. Assessment of Cell Viability in Drug Therapy: IC<sub>50</sub> and Other New Time-Independent Indices for Evaluating Chemotherapy Efficacy - PMC [[pmc.ncbi.nlm.nih.gov](#)]
- 24. [mdpi.com](#) [[mdpi.com](#)]
- 25. [mdpi.com](#) [[mdpi.com](#)]
- 26. Identification of Promising Drug Candidates against Prostate Cancer through Computationally-Driven Drug Repurposing [[mdpi.com](#)]
- 27. [miltenyibiotec.com](#) [[miltenyibiotec.com](#)]
- 28. Synergistic Growth Inhibition of HT-29 Colon and MCF-7 Breast Cancer Cells with Simultaneous and Sequential Combinations of Antineoplastics and CNS Drugs - PubMed [[pubmed.ncbi.nlm.nih.gov](#)]
- 29. [researchgate.net](#) [[researchgate.net](#)]
- 30. Reduced pim-1 expression increases chemotherapeutic drug sensitivity in human androgen-independent prostate cancer cells by inducing apoptosis - PMC [[pmc.ncbi.nlm.nih.gov](#)]
- 31. Frontiers | Parsing the Role of PPARs in Macrophage Processes [[frontiersin.org](#)]
- 32. [encyclopedia.pub](#) [[encyclopedia.pub](#)]
- 33. [researchgate.net](#) [[researchgate.net](#)]
- 34. Effects of decursinol angelate on viability and apoptosis in PC-3 prostate cancer cells: In vitro study - PMC [[pmc.ncbi.nlm.nih.gov](#)]

- 35. Inhibition of proliferation of prostate cancer cell line, PC-3, in vitro and in vivo using (-)-gossypol - PMC [pmc.ncbi.nlm.nih.gov]
- 36. Highly sensitive live-cell imaging-based cytotoxicity assay enables functional validation of rare epitope-specific CTLs - PMC [pmc.ncbi.nlm.nih.gov]
- 37. PD-0332991 combined with cisplatin inhibits nonsmall cell lung cancer and reversal of cisplatin resistance - PMC [pmc.ncbi.nlm.nih.gov]
- 38. Apoptosis-mediated antiproliferation of A549 lung cancer cells mediated by Eugenia aquea leaf compound 2',4'-dihydroxy-6'-methoxy-3',5'-dimethylchalcone and its molecular interaction with caspase receptor in molecular docking simulation - PMC [pmc.ncbi.nlm.nih.gov]
- 39. Gold Nanoparticles Induced Size Dependent Cytotoxicity on Human Alveolar Adenocarcinoma Cells by Inhibiting the Ubiquitin Proteasome System - PMC [pmc.ncbi.nlm.nih.gov]
- To cite this document: BenchChem. [Technical Support Center: Addressing GW7845 Resistance in Cell Lines]. BenchChem, [2025]. [Online PDF]. Available at: [https://www.benchchem.com/product/b1672479#addressing-gw7845-resistance-in-cell-lines]

---

#### Disclaimer & Data Validity:

The information provided in this document is for Research Use Only (RUO) and is strictly not intended for diagnostic or therapeutic procedures. While BenchChem strives to provide accurate protocols, we make no warranties, express or implied, regarding the fitness of this product for every specific experimental setup.

**Technical Support:** The protocols provided are for reference purposes. Unsure if this reagent suits your experiment? [[Contact our Ph.D. Support Team for a compatibility check](#)]

**Need Industrial/Bulk Grade?** [Request Custom Synthesis Quote](#)

# BenchChem

Our mission is to be the trusted global source of essential and advanced chemicals, empowering scientists and researchers to drive progress in science and industry.

## Contact

Address: 3281 E Guasti Rd

Ontario, CA 91761, United States

Phone: (601) 213-4426

Email: [info@benchchem.com](mailto:info@benchchem.com)