

Technical Support Center: Accurate Measurement of H-Tyr(3-I)-OH-13C6

Author: BenchChem Technical Support Team. **Date:** December 2025

Compound of Interest

Compound Name: *H-Tyr(3-I)-OH-13C6*

Cat. No.: *B15556811*

[Get Quote](#)

Welcome to the technical support center for the accurate measurement of **H-Tyr(3-I)-OH-13C6**. This resource is designed for researchers, scientists, and drug development professionals to provide clear guidance on instrument calibration, experimental procedures, and troubleshooting.

Frequently Asked Questions (FAQs)

Q1: What is **H-Tyr(3-I)-OH-13C6** and why is it used as an internal standard?

A1: **H-Tyr(3-I)-OH-13C6** is the stable isotope-labeled form of 3-iodo-L-tyrosine, containing six Carbon-13 atoms.^[1] It is an effective tyrosine hydroxylase inhibitor and an intermediate in thyroid hormone production.^[1] In quantitative mass spectrometry-based assays, it serves as an ideal internal standard. Because it is chemically identical to the unlabeled analyte, it co-elutes chromatographically and exhibits the same ionization efficiency. The mass difference allows for its distinct detection and enables accurate quantification by correcting for variations in sample preparation and instrument response.

Q2: Which ionization technique is best suited for **H-Tyr(3-I)-OH-13C6** analysis?

A2: Electrospray ionization (ESI) is a commonly used and effective technique for the analysis of modified amino acids like iodinated tyrosines. It is a soft ionization method that minimizes fragmentation of the analyte, which is crucial for accurate quantification.

Q3: How can I distinguish a true ^{13}C labeled peak from background noise, especially at low enrichment levels?

A3: Distinguishing a true signal from background noise is critical. Here are a few strategies:

- **Isotopic Pattern Analysis:** A genuine ^{13}C labeled fragment will show a characteristic isotopic distribution. The spacing and relative intensities of the isotopologue peaks ($M+1$, $M+2$, etc.) should follow a predictable pattern based on the number of carbon atoms and the level of ^{13}C enrichment. Deviations from this pattern may indicate background noise or interference. [\[2\]](#)
- **Blank Analysis:** It is essential to run a blank sample (the sample matrix without the ^{13}C labeled analyte) through the entire experimental workflow. This helps to identify background ions that are consistently present. [\[2\]](#)
- **Data Analysis Software:** Specialized software can aid in deconvoluting complex spectra, identifying isotopic patterns, and subtracting background signals. [\[2\]](#)

Q4: What are common sources of background noise in mass spectrometry experiments with ^{13}C labeled fragments?

A4: Background noise in mass spectrometry can come from several sources, including chemical, electronic, and environmental factors. For ^{13}C labeling experiments, chemical noise is often the most significant contributor. [\[2\]](#) This can originate from:

- **Sample Matrix:** Complex biological samples can contain numerous endogenous compounds that interfere with the signal of interest. [\[2\]](#)
- **Contaminated Solvents:** Using fresh, high-purity, LC-MS grade solvents is crucial to reduce baseline noise. [\[2\]](#)
- **Contaminated LC System:** The entire LC system should be flushed with high-purity solvents to ensure a clean baseline. [\[2\]](#)
- **Plasticizer Contamination:** Switching to glass or polypropylene labware and avoiding plastic containers for long-term solvent storage can reduce phthalate-related peaks. [\[2\]](#)

Troubleshooting Guide

Issue 1: Poor Signal Intensity or No Peak Detected

Possible Cause	Troubleshooting Step	Expected Outcome
Suboptimal Sample Preparation	Review the sample preparation protocol. Ensure complete protein precipitation and efficient extraction. For complex matrices, consider solid-phase extraction (SPE) for cleaner samples.[3]	Improved signal-to-noise ratio and peak intensity.
Inefficient Ionization	Optimize ESI source parameters (e.g., spray voltage, gas flow, temperature). Ensure the mobile phase composition is suitable for ionization; adding a small amount of formic acid (e.g., 0.1%) can promote protonation.[4]	Enhanced signal intensity.
Incorrect Mass Spectrometer Settings	Verify that the mass spectrometer is calibrated correctly and operating in the appropriate scan mode (e.g., SIM or MRM) for the target m/z of H-Tyr(3-I)-OH-13C6.	Detection of the target analyte at the expected mass.
Instrument Contamination	Clean the ion source and other components of the mass spectrometer as per the manufacturer's guidelines.[5]	Reduction in background noise and potential improvement in signal intensity.

Issue 2: High Background Noise and Matrix Effects

Possible Cause	Troubleshooting Step	Expected Outcome
Insufficient Sample Cleanup	Employ more rigorous sample preparation techniques like solid-phase extraction (SPE) or liquid-liquid extraction (LLE) to remove interfering matrix components. [3] [6]	A cleaner baseline and reduced matrix-induced ion suppression or enhancement.
Suboptimal Chromatographic Separation	Optimize the LC gradient to separate H-Tyr(3-I)-OH from co-eluting matrix components. Experiment with different column chemistries.	Better resolution of the analyte peak from interfering peaks.
Matrix-Induced Ion Suppression/Enhancement	The use of a stable isotope-labeled internal standard like H-Tyr(3-I)-OH- ¹³ C ₆ is the most effective way to compensate for matrix effects. [7] Ensure the internal standard is added early in the sample preparation process.	Accurate and reproducible quantification despite matrix effects.

Issue 3: Inaccurate Quantification and Poor Reproducibility

Possible Cause	Troubleshooting Step	Expected Outcome
Improper Calibration Curve	Prepare calibration standards in a matrix that closely matches the study samples to account for matrix effects. Ensure the concentration range of the calibration curve brackets the expected analyte concentrations.	A linear calibration curve with a good correlation coefficient ($R^2 > 0.99$), leading to accurate quantification.
Inconsistent Sample Preparation	Standardize all sample preparation steps, including volumes, incubation times, and temperatures. Use automated liquid handlers if available to improve precision.	Improved reproducibility of results across different samples.
Instrument Instability	Regularly check the stability of the mass spectrometer by injecting a standard solution at regular intervals during the analytical run.	Consistent signal response over time, ensuring reliable quantification.

Experimental Protocols

Detailed Methodology for LC-MS/MS Quantification of H-Tyr(3-I)-OH

This protocol is a synthesized approach based on methods for similar halogenated and isotope-labeled amino acids.

1. Sample Preparation (from Plasma)

- **Protein Precipitation:** To 100 μL of plasma, add 10 μL of **H-Tyr(3-I)-OH-13C6** internal standard solution (concentration to be optimized based on expected analyte levels). Add 400 μL of ice-cold acetonitrile containing 0.1% formic acid to precipitate proteins.

- Vortex and Centrifuge: Vortex the mixture for 1 minute, then centrifuge at 14,000 x g for 10 minutes at 4°C.[4]
- Supernatant Transfer: Carefully transfer the supernatant to a clean tube.
- Evaporation: Dry the supernatant under a gentle stream of nitrogen at 40°C.
- Reconstitution: Reconstitute the dried extract in 100 µL of the initial mobile phase (e.g., 95:5 water:acetonitrile with 0.1% formic acid).

2. Liquid Chromatography (LC)

- Column: A C18 reversed-phase column (e.g., 2.1 mm x 100 mm, 3.5 µm particle size) is suitable.[4]
- Mobile Phase A: 0.1% formic acid in water.
- Mobile Phase B: 0.1% formic acid in acetonitrile.
- Gradient: A linear gradient from 5% to 95% B over several minutes, followed by a wash and re-equilibration step. The gradient should be optimized to ensure baseline separation of the analyte from matrix interferences.
- Flow Rate: 0.3 mL/min.
- Injection Volume: 5-10 µL.

3. Mass Spectrometry (MS)

- Ionization: Electrospray ionization (ESI) in positive ion mode.
- Scan Mode: Multiple Reaction Monitoring (MRM) for highest sensitivity and specificity.
- MRM Transitions:
 - H-Tyr(3-I)-OH: Precursor ion $[M+H]^+$ → Product ion (To be determined by infusion and fragmentation analysis).

- **H-Tyr(3-I)-OH-13C6**: Precursor ion $[M+6+H]^+$ → Product ion (To be determined by infusion and fragmentation analysis).
- Instrument Parameters: Optimize cone voltage and collision energy for each transition to maximize signal intensity.[4]

4. Calibration and Quantification

- Prepare a series of calibration standards by spiking known concentrations of H-Tyr(3-I)-OH into a blank matrix (e.g., charcoal-stripped plasma).
- Add a constant concentration of the **H-Tyr(3-I)-OH-13C6** internal standard to each calibrator and sample.
- Construct a calibration curve by plotting the peak area ratio of the analyte to the internal standard against the analyte concentration.
- Determine the concentration of the analyte in the unknown samples by interpolating their peak area ratios from the calibration curve.

Visualizations

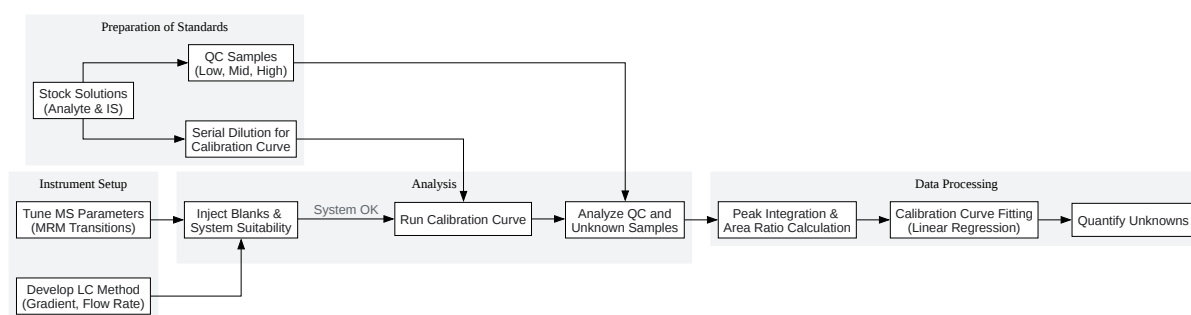

[Click to download full resolution via product page](#)

Caption: Workflow for instrument calibration and sample analysis.

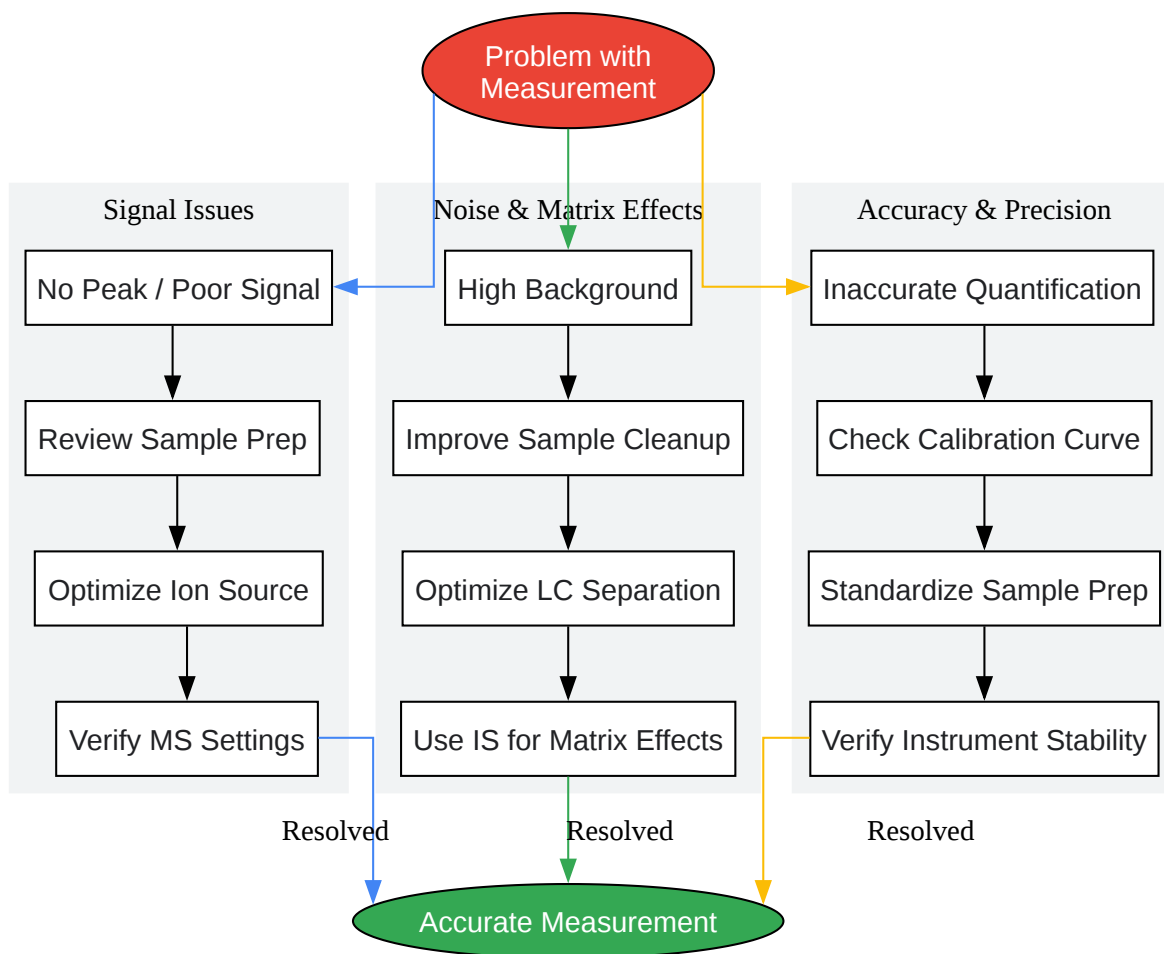

[Click to download full resolution via product page](#)

Caption: A logical troubleshooting workflow for common issues.

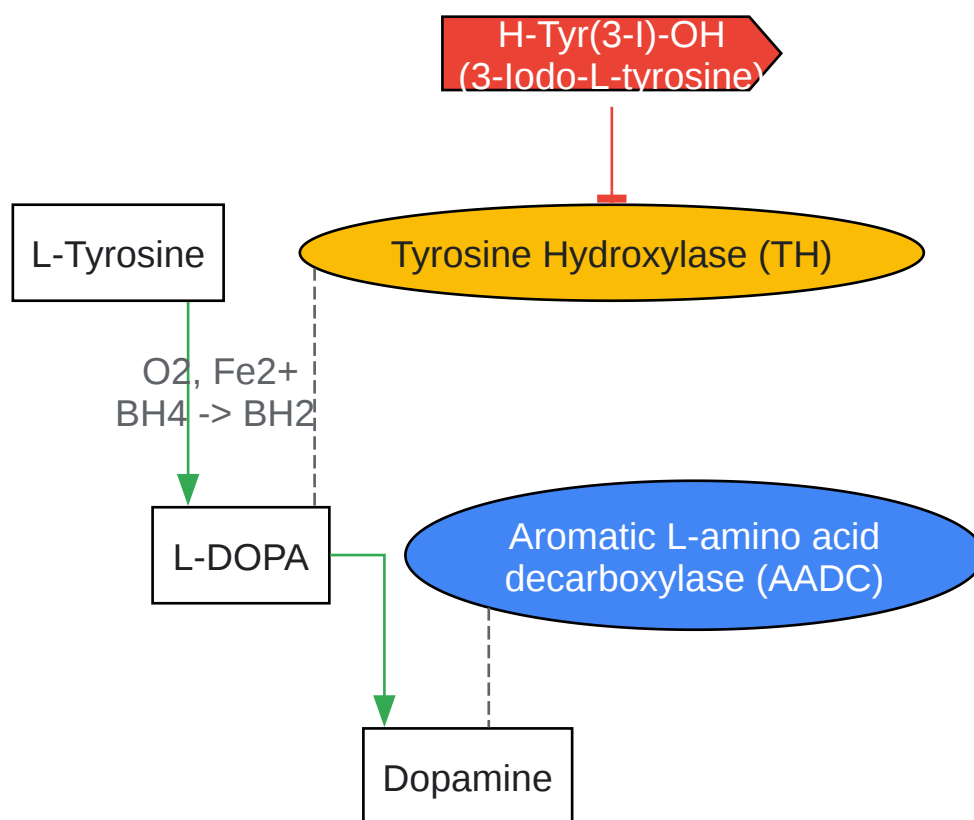

[Click to download full resolution via product page](#)

Caption: Inhibition of the catecholamine synthesis pathway.

Need Custom Synthesis?

BenchChem offers custom synthesis for rare earth carbides and specific isotopic labeling.

Email: info@benchchem.com or [Request Quote Online](#).

References

- 1. medchemexpress.com [medchemexpress.com]
- 2. chromatographyonline.com [chromatographyonline.com]
- 3. Evaluation of different isotope dilution mass spectrometry strategies for the characterization of naturally abundant and isotopically labelled peptide standards - PMC [pmc.ncbi.nlm.nih.gov]

- 4. Development and validation of an LC-MS/MS method for tyrphostin A9 - PMC [pmc.ncbi.nlm.nih.gov]
- 5. researchgate.net [researchgate.net]
- 6. Sample treatment based on extraction techniques in biological matrices - PubMed [pubmed.ncbi.nlm.nih.gov]
- 7. rsc.org [rsc.org]
- To cite this document: BenchChem. [Technical Support Center: Accurate Measurement of H-Tyr(3-I)-OH-13C6]. BenchChem, [2025]. [Online PDF]. Available at: [https://www.benchchem.com/product/b15556811#calibrating-instrument-for-accurate-h-tyr-3-i-oh-13c6-measurement]

Disclaimer & Data Validity:

The information provided in this document is for Research Use Only (RUO) and is strictly not intended for diagnostic or therapeutic procedures. While BenchChem strives to provide accurate protocols, we make no warranties, express or implied, regarding the fitness of this product for every specific experimental setup.

Technical Support: The protocols provided are for reference purposes. Unsure if this reagent suits your experiment? [[Contact our Ph.D. Support Team for a compatibility check](#)]

Need Industrial/Bulk Grade? [Request Custom Synthesis Quote](#)

BenchChem

Our mission is to be the trusted global source of essential and advanced chemicals, empowering scientists and researchers to drive progress in science and industry.

Contact

Address: 3281 E Guasti Rd
Ontario, CA 91761, United States
Phone: (601) 213-4426
Email: info@benchchem.com