

# TMX-4100 experimental protocol for cell culture

**Author:** BenchChem Technical Support Team. **Date:** December 2025

## Compound of Interest

Compound Name: TMX-4100

Cat. No.: B15621833

[Get Quote](#)

## Application Notes: TMX-4100

### Introduction

**TMX-4100** is a potent and selective, ATP-competitive inhibitor of MEK1 and MEK2 (Mitogen-activated protein kinase kinase). As a critical component of the Ras/Raf/MEK/ERK signaling pathway, MEK1/2's phosphorylation and subsequent activation of ERK1/2 play a pivotal role in regulating cell proliferation, differentiation, and survival. Dysregulation of this pathway is a hallmark of many human cancers, making MEK an attractive target for therapeutic intervention. **TMX-4100** has been developed for preclinical research to investigate the cellular consequences of MEK inhibition in various cancer cell models. These notes provide detailed protocols for assessing the in-vitro efficacy and mechanism of action of **TMX-4100**.

### Mechanism of Action

**TMX-4100** specifically targets the dual-specificity kinases MEK1 and MEK2. By binding to the ATP pocket, it prevents the phosphorylation of MEK's downstream targets, ERK1 and ERK2 (also known as p44/42 MAPK). This blockade leads to the inhibition of the entire signaling cascade, resulting in decreased cell proliferation and the induction of apoptosis in tumor cells with activating mutations in upstream components like BRAF or Ras.

## Experimental Protocols

### General Cell Culture and Maintenance

This protocol outlines the standard procedure for maintaining and preparing cancer cell lines (e.g., A375 melanoma, HT-29 colon cancer) for treatment with **TMX-4100**.

- Materials:
  - Complete growth medium (e.g., DMEM or RPMI-1640) supplemented with 10% Fetal Bovine Serum (FBS) and 1% Penicillin-Streptomycin.
  - Phosphate-Buffered Saline (PBS), sterile.
  - Trypsin-EDTA (0.25%).
  - Cell culture flasks (T-75).
  - 6-well, 12-well, and 96-well cell culture plates.
  - **TMX-4100** stock solution (10 mM in DMSO).
- Procedure:
  - Maintain cells in a 37°C incubator with 5% CO<sub>2</sub>.
  - For passaging, wash cells with PBS once they reach 80-90% confluency.
  - Aspirate PBS and add 1-2 mL of Trypsin-EDTA. Incubate for 3-5 minutes until cells detach.
  - Neutralize trypsin with 5-10 mL of complete growth medium and transfer the cell suspension to a conical tube.
  - Centrifuge at 200 x g for 5 minutes.
  - Aspirate the supernatant and resuspend the cell pellet in fresh medium.
  - Seed cells into new flasks or plates for experiments at the desired density. For experiments, allow cells to adhere for 24 hours before treatment.

## Cell Viability Assay (MTT Assay)

This protocol is designed to determine the half-maximal inhibitory concentration (IC<sub>50</sub>) of **TMX-4100** by measuring its effect on cell viability.

- Materials:
  - Cells seeded in a 96-well plate (e.g., 5,000 cells/well).
  - **TMX-4100** serial dilutions (e.g., 0.1 nM to 10 μM) in complete growth medium.
  - MTT (3-(4,5-dimethylthiazol-2-yl)-2,5-diphenyltetrazolium bromide) solution (5 mg/mL in PBS).
  - DMSO.
  - Microplate reader (570 nm wavelength).
- Procedure:
  - Seed cells in a 96-well plate and allow them to attach overnight.
  - Remove the medium and add 100 μL of medium containing various concentrations of **TMX-4100** or vehicle control (DMSO) to triplicate wells.
  - Incubate the plate for 72 hours at 37°C, 5% CO<sub>2</sub>.
  - Add 20 μL of MTT solution to each well and incubate for 4 hours.
  - Aspirate the medium and add 150 μL of DMSO to each well to dissolve the formazan crystals.
  - Shake the plate for 10 minutes at room temperature.
  - Measure the absorbance at 570 nm using a microplate reader.
  - Calculate cell viability as a percentage relative to the vehicle-treated control cells and plot the dose-response curve to determine the IC<sub>50</sub> value.

## Western Blot Analysis for ERK Phosphorylation

This protocol assesses the on-target effect of **TMX-4100** by measuring the phosphorylation level of ERK1/2.

- Materials:
  - Cells seeded in a 6-well plate.
  - **TMX-4100** at various concentrations.
  - RIPA Lysis Buffer with protease and phosphatase inhibitors.
  - BCA Protein Assay Kit.
  - SDS-PAGE gels and running buffer.
  - Transfer buffer and PVDF membrane.
  - Blocking buffer (5% non-fat milk or BSA in TBST).
  - Primary antibodies: Rabbit anti-phospho-ERK1/2 (Thr202/Tyr204), Rabbit anti-Total ERK1/2, Mouse anti- $\beta$ -Actin.
  - Secondary antibodies: HRP-linked anti-rabbit IgG, HRP-linked anti-mouse IgG.
  - Enhanced Chemiluminescence (ECL) substrate.
  - Chemiluminescence imaging system.
- Procedure:
  - Seed cells (e.g.,  $5 \times 10^5$  cells/well) in 6-well plates and allow them to attach overnight.
  - Treat cells with **TMX-4100** at the desired concentrations for 2 hours.
  - Wash cells with ice-cold PBS and lyse them with 100  $\mu$ L of RIPA buffer.
  - Centrifuge lysates at 14,000 x g for 15 minutes at 4°C. Collect the supernatant.
  - Determine protein concentration using the BCA assay.

- Denature 20-30 µg of protein per sample by boiling in Laemmli sample buffer.
- Separate proteins by SDS-PAGE and transfer them to a PVDF membrane.
- Block the membrane for 1 hour at room temperature.
- Incubate the membrane with primary antibodies overnight at 4°C.
- Wash the membrane with TBST and incubate with HRP-conjugated secondary antibodies for 1 hour.
- Wash again and apply ECL substrate.
- Visualize protein bands using an imaging system. Quantify band intensity using software like ImageJ.

## Quantitative Data Summary

Table 1: Effect of **TMX-4100** on A375 Cell Viability

TMX-4100 Conc. (nM)	Average Absorbance (570 nm)	Std. Deviation	% Viability vs. Control
0 (Vehicle)	1.25	0.08	100%
0.1	1.21	0.07	96.8%
1	1.05	0.06	84.0%
10	0.64	0.05	51.2%
100	0.18	0.03	14.4%
1000	0.09	0.02	7.2%
IC50 Value	~10.5 nM	-	-

Table 2: Densitometry Analysis of ERK Phosphorylation

Treatment (2 hours)	p-ERK / Total ERK Ratio (Normalized)	Std. Deviation	% Inhibition of p-ERK
Vehicle Control	1.00	0.09	0%
TMX-4100 (10 nM)	0.45	0.05	55%
TMX-4100 (100 nM)	0.12	0.03	88%
TMX-4100 (500 nM)	0.04	0.02	96%

## Visualizations

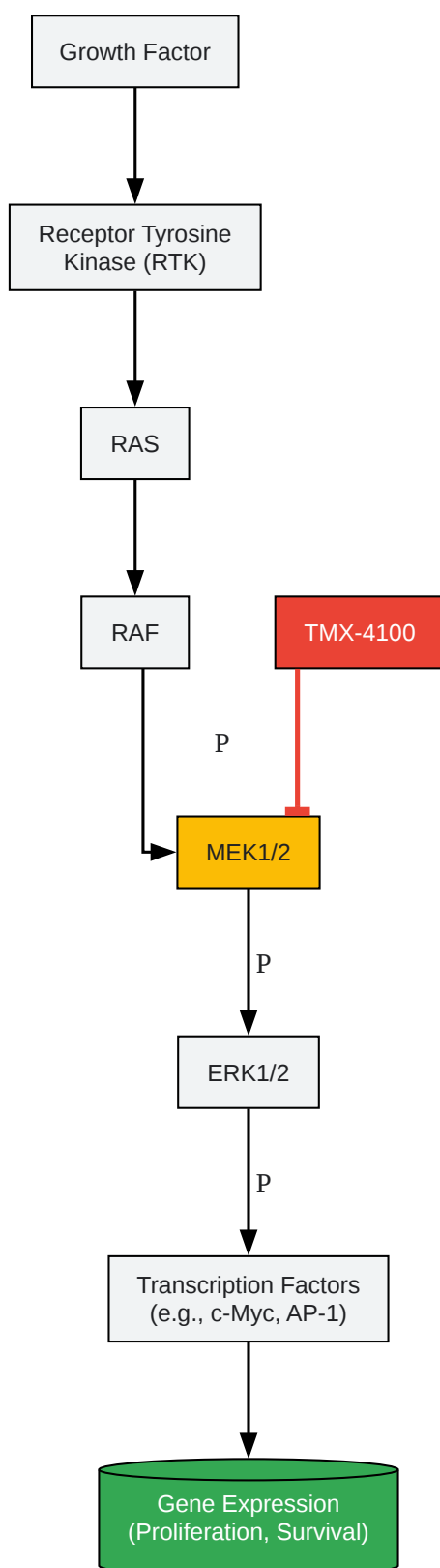

[Click to download full resolution via product page](#)

**TMX-4100** inhibits the MAPK/ERK signaling pathway by targeting MEK1/2.

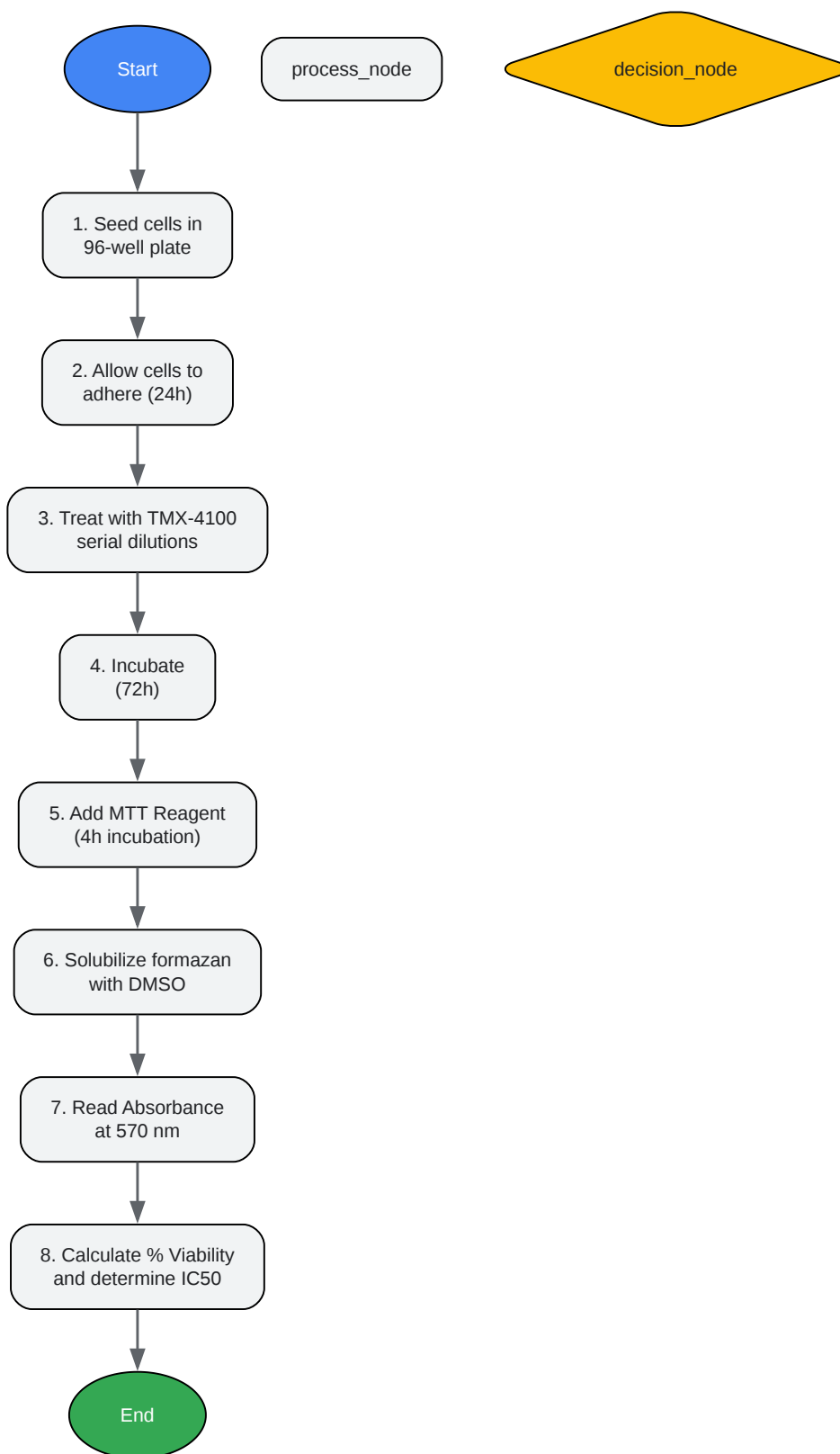

[Click to download full resolution via product page](#)

Experimental workflow for the MTT-based cell viability assay.



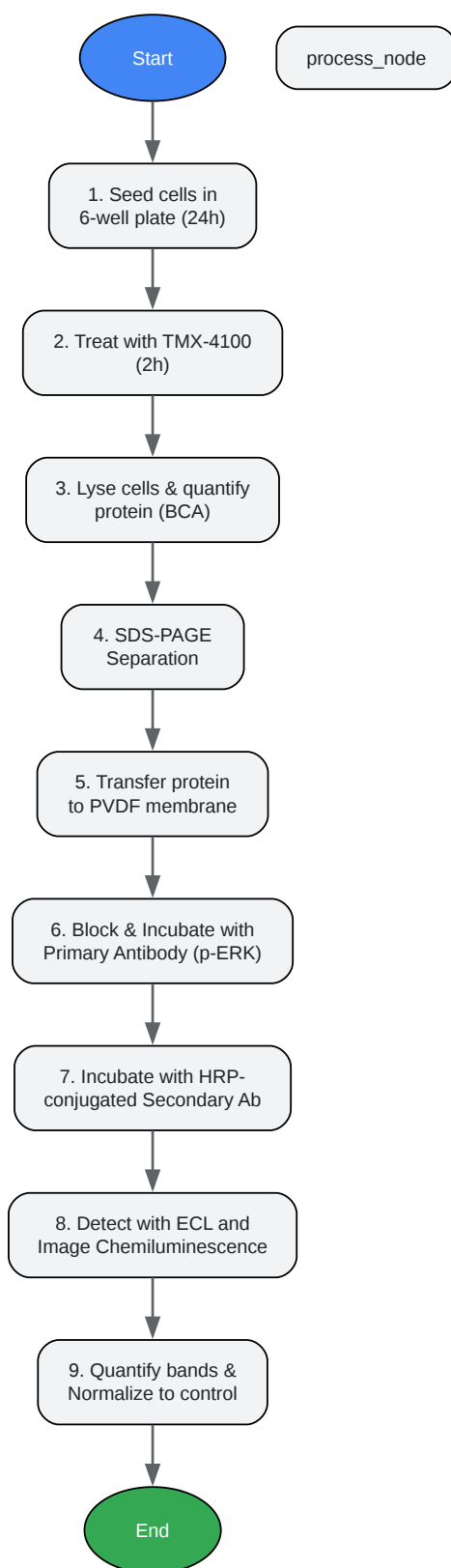

[Click to download full resolution via product page](#)

Experimental workflow for Western Blot analysis of p-ERK.

- To cite this document: BenchChem. [TMX-4100 experimental protocol for cell culture]. BenchChem, [2025]. [Online PDF]. Available at: [https://www.benchchem.com/product/b15621833#tmx-4100-experimental-protocol-for-cell-culture]

---

### Disclaimer & Data Validity:

The information provided in this document is for Research Use Only (RUO) and is strictly not intended for diagnostic or therapeutic procedures. While BenchChem strives to provide accurate protocols, we make no warranties, express or implied, regarding the fitness of this product for every specific experimental setup.

**Technical Support:** The protocols provided are for reference purposes. Unsure if this reagent suits your experiment? [[Contact our Ph.D. Support Team for a compatibility check](#)]

**Need Industrial/Bulk Grade?** [Request Custom Synthesis Quote](#)

## BenchChem

Our mission is to be the trusted global source of essential and advanced chemicals, empowering scientists and researchers to drive progress in science and industry.

### Contact

Address: 3281 E Guasti Rd

Ontario, CA 91761, United States

Phone: (601) 213-4426

Email: [info@benchchem.com](mailto:info@benchchem.com)