

# Structure-activity relationship of BNC375 and its analogs

**Author:** BenchChem Technical Support Team. **Date:** December 2025

## Compound of Interest

Compound Name: BNC375

Cat. No.: B8107612

[Get Quote](#)

## Technical Support Center: BNC375 and its Analogs

This technical support center provides researchers, scientists, and drug development professionals with comprehensive information on the structure-activity relationship (SAR) of **BNC375** and its analogs. It includes troubleshooting guides, frequently asked questions (FAQs), detailed experimental protocols, and data summaries to facilitate your research.

### Structure-Activity Relationship (SAR) Summary

**BNC375** is a potent, selective, and orally available Type I positive allosteric modulator (PAM) of the  $\alpha 7$  nicotinic acetylcholine receptor ( $\alpha 7$  nAChR).[1][2][3] The SAR of **BNC375** and its analogs has been systematically explored to optimize potency, selectivity, and pharmacokinetic properties. Key determinants of activity include the stereochemistry of the central cyclopropyl ring and substitutions on the flanking aromatic moieties.

### Key Findings:

- **Stereochemistry is Crucial:** The stereochemistry of the central cyclopropyl ring dictates the type of allosteric modulation. The (R,R)-enantiomer, **BNC375**, and its analogs are Type I PAMs, which potentiate the peak acetylcholine (ACh) response with minimal effect on receptor desensitization.[1][4] In contrast, the (S,S)-enantiomers are Type II PAMs, which increase the peak response and prolong the channel open time by delaying desensitization.

- **Aniline Ring Substitutions:** Modifications to the aniline (right-hand side) ring can fine-tune the kinetic profile. The introduction of strong electron-withdrawing groups on the aniline ring tends to reduce the Type II character of the compounds.
- **Lipophilicity and ADME Properties:** The initial lead compounds had high lipophilicity. Subsequent optimization focused on reducing lipophilicity to improve aqueous solubility and metabolic stability while maintaining high potency.

## Quantitative SAR Data of BNC375 Analogs

The following tables summarize the in vitro activity of key **BNC375** analogs. The data is adapted from the primary literature and its supplementary information.

Table 1: Effect of Stereochemistry on  $\alpha 7$  nAChR Potentiation

Compound	Stereochemistry	P3 (% Potentiation at 3 $\mu$ M)	AUC/Pmax	Modulator Type
BNC375 (R,R)-13	R,R	7900	1.7	Type I
(S,S)-13	S,S	9890	25	Type II

P3 represents the percent potentiation of the ACh EC20 response in the presence of 3  $\mu$ M of the compound. AUC/Pmax is the ratio of the area under the curve to the peak current, indicating the effect on desensitization.

Table 2: SAR of the Right-Hand Side (RHS) Aniline Moiety

Compound	RHS Substitution	P3 (% Potentiation at 3 $\mu$ M)	clogP
BNC375	5-chloro-2-methoxyphenyl	7900	4.2
Analog A	2,5-dichlorophenyl	6500	4.5
Analog B	2-chloro-5-(trifluoromethyl)phenyl	5800	4.8
Analog C	2-methoxyphenyl	4500	3.5
Analog D	Phenyl	2100	3.1

clogP is the calculated logP, a measure of lipophilicity.

## Diagrams

### BNC375 Mechanism of Action Workflow

BNC375 Mechanism of Action

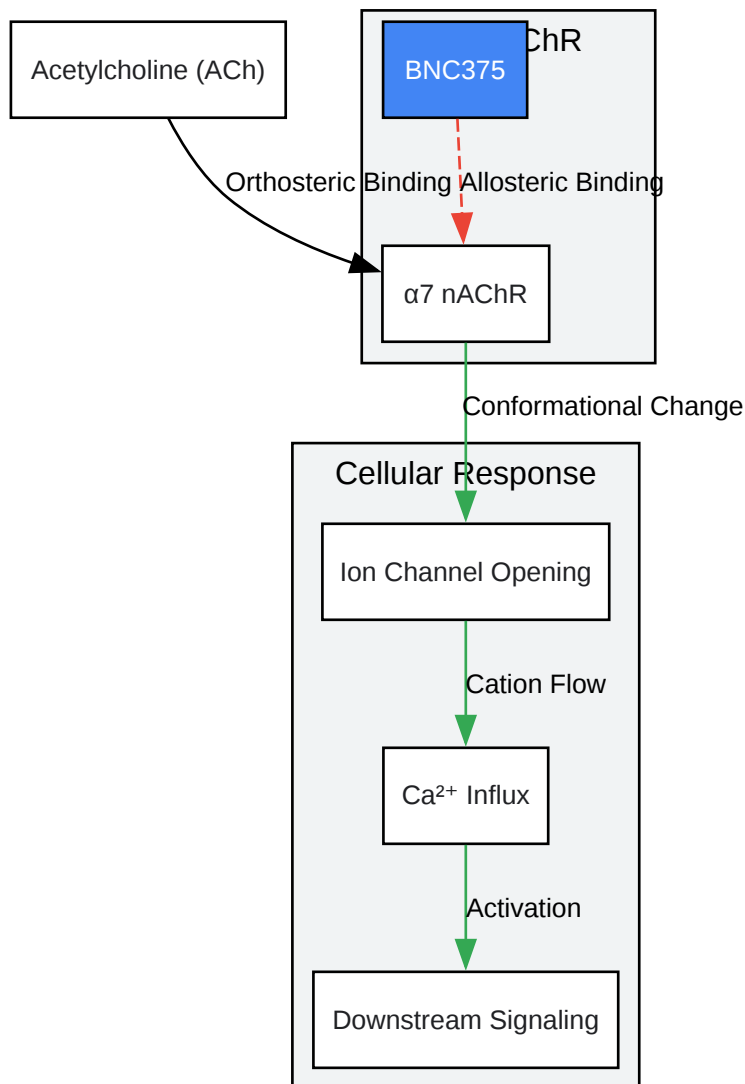

[Click to download full resolution via product page](#)

Caption: Workflow of **BNC375** as a positive allosteric modulator of the  $\alpha 7$  nAChR.

## $\alpha 7$ nAChR Signaling Pathway

**α7 nAChR Downstream Signaling**

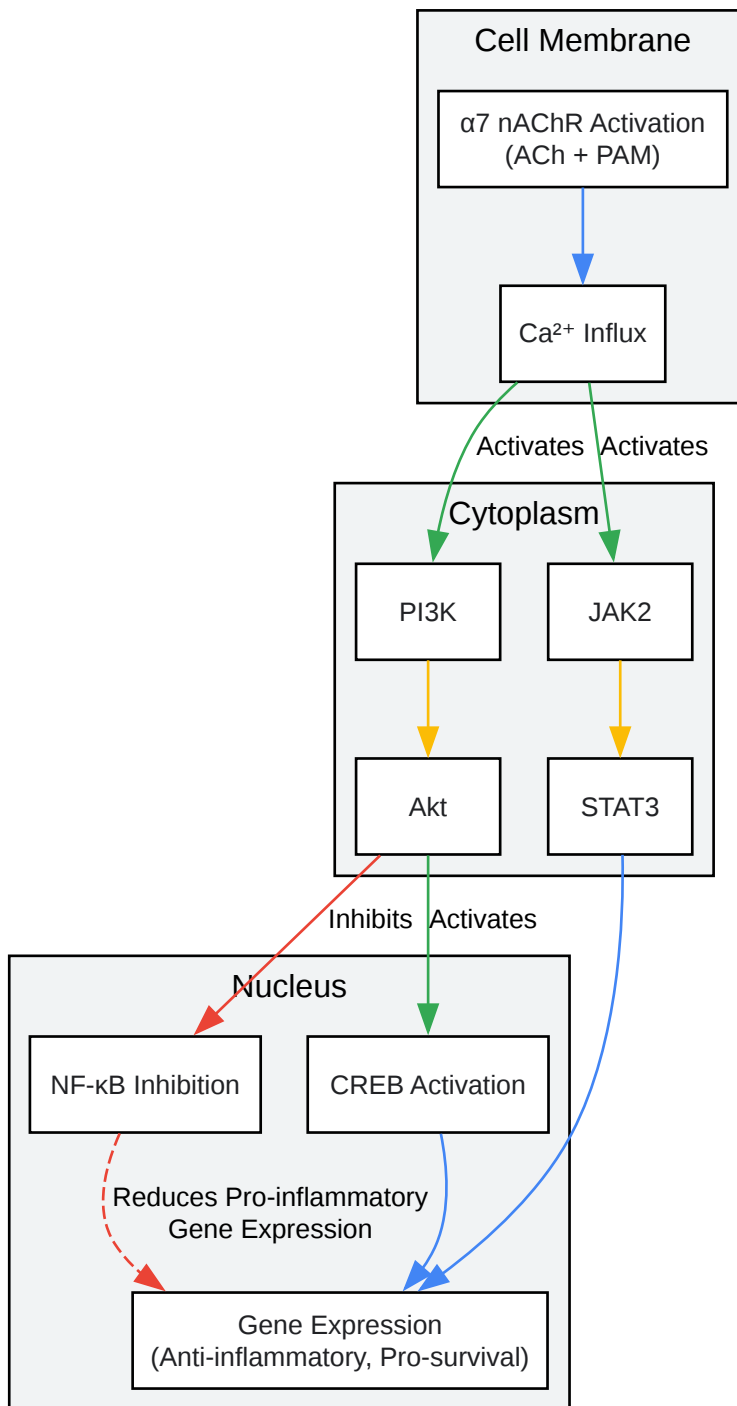

[Click to download full resolution via product page](#)

Caption: Key downstream signaling pathways activated by α7 nAChR potentiation.

## Experimental Protocols

### Patch-Clamp Electrophysiology for $\alpha 7$ nAChR PAMs

This protocol describes the characterization of **BNC375** and its analogs using whole-cell patch-clamp electrophysiology in a cell line stably expressing human  $\alpha 7$  nAChRs (e.g., GH4C1 or HEK293 cells).

#### Materials:

- Cells: GH4C1 or HEK293 cells stably transfected with human  $\alpha 7$  nAChR.
- External Solution (in mM): 140 NaCl, 5 KCl, 2 CaCl<sub>2</sub>, 1 MgCl<sub>2</sub>, 10 HEPES, 10 Glucose (pH 7.4 with NaOH).
- Internal Solution (in mM): 140 KCl, 1 MgCl<sub>2</sub>, 10 EGTA, 10 HEPES, 4 Mg-ATP (pH 7.2 with KOH).
- Agonist: Acetylcholine (ACh) chloride.
- Test Compounds: **BNC375** or analogs dissolved in DMSO (final concentration  $\leq 0.1\%$ ).
- Patch-clamp rig: Amplifier, micromanipulator, perfusion system.

#### Methodology:

- Cell Preparation: Plate cells onto glass coverslips 24-48 hours before the experiment.
- Pipette Preparation: Pull borosilicate glass capillaries to a resistance of 3-5 M $\Omega$  when filled with internal solution.
- Whole-Cell Configuration: Obtain a gigaseal and establish whole-cell configuration. Clamp the cell at a holding potential of -70 mV.
- Compound Application:
  - Prepare an ACh solution at its EC<sub>20</sub> concentration in the external solution.
  - Prepare solutions of test compounds (e.g., at 3  $\mu$ M) in the ACh EC<sub>20</sub> solution.

- Data Acquisition:
  - Establish a stable baseline recording by perfusing the cell with the external solution.
  - Apply the ACh EC20 solution for 2-3 seconds to record the control response.
  - Wash the cell with the external solution for at least 2 minutes.
  - Apply the test compound + ACh EC20 solution for 2-3 seconds.
  - Record the potentiated current.
  - Perform a final washout and re-application of ACh EC20 to check for recovery.
- Data Analysis:
  - Measure the peak amplitude of the current in the absence ( $I_{\text{control}}$ ) and presence ( $I_{\text{test}}$ ) of the test compound.
  - Calculate the percent potentiation:  $\text{Potentiation (\%)} = \left[ \frac{(I_{\text{test}} - I_{\text{control}})}{I_{\text{control}}} * 100 \right]$ .
  - To distinguish between Type I and Type II PAMs, measure the area under the curve (AUC) and the peak current ( $P_{\text{max}}$ ). A significant increase in the AUC/ $P_{\text{max}}$  ratio indicates Type II activity.

## Troubleshooting and FAQs

Q1: My compound is not showing any potentiation.

- A1: Solubility Issues: Ensure your compound is fully dissolved. **BNC375** and its analogs can be lipophilic. Prepare a concentrated stock in 100% DMSO and dilute it into the final aqueous solution just before use. The final DMSO concentration should be kept low (e.g.,  $\leq 0.1\%$ ) to avoid solvent effects.
- A2: Compound Stability: Some analogs may be unstable in aqueous solutions. Prepare fresh dilutions for each experiment.

- A3: Incorrect Agonist Concentration: The potentiation by a PAM is highly dependent on the agonist concentration used. Ensure you are using a sub-maximal concentration of ACh (e.g., EC10-EC20). If the agonist concentration is too high, the potentiation window will be smaller.
- A4: Cell Health and Receptor Expression: Use cells at a low passage number and ensure high levels of  $\alpha 7$  nAChR expression. Poor cell health can lead to small and variable currents.

Q2: I am seeing a large run-down of the current over time.

- A1: Cell Viability: This is a common issue in patch-clamp experiments. Ensure your internal solution contains ATP to support cell metabolism. Monitor the access resistance throughout the experiment; a significant increase indicates a decline in seal quality.
- A2: Receptor Desensitization: While **BNC375** is a Type I PAM, repeated or prolonged application of high concentrations of ACh can lead to receptor desensitization. Ensure adequate washout periods (at least 2 minutes) between applications.

Q3: How do I differentiate between a Type I and a Type II PAM?

- A1: Analyze the Current Decay: A Type I PAM like **BNC375** primarily increases the peak current amplitude with little to no effect on the decay kinetics (desensitization). A Type II PAM will also increase the peak amplitude but will significantly slow the decay of the current.
- A2: Calculate AUC/Pmax Ratio: As described in the protocol, this ratio is a quantitative measure of the effect on desensitization. A stable ratio in the presence of the compound compared to the control indicates Type I activity, while a large increase indicates Type II activity.

Q4: Can **BNC375** activate the  $\alpha 7$  nAChR in the absence of an agonist?

- A1: No Intrinsic Agonist Activity: **BNC375** is a true PAM and does not have intrinsic agonist activity. It requires the presence of an orthosteric agonist like acetylcholine to modulate receptor function. Experiments have shown that **BNC375** alone does not evoke currents in cells expressing  $\alpha 7$  nAChRs.

Q5: What are the recommended storage conditions for **BNC375**?



- A1: Stock Solution Storage: For long-term storage, **BNC375** stock solutions in DMSO should be stored at -80°C for up to 6 months or at -20°C for up to 1 month. Avoid repeated freeze-thaw cycles.

#### Need Custom Synthesis?

BenchChem offers custom synthesis for rare earth carbides and specific isotopic labeling.

Email: [info@benchchem.com](mailto:info@benchchem.com) or [Request Quote Online](#).

## References

- 1. Role of  $\alpha 7$  nicotinic receptor in the immune system and intracellular signaling pathways - PMC [pmc.ncbi.nlm.nih.gov]
- 2. Overview - Nicotinic Acetylcholine Receptor Signaling in Neuroprotection - NCBI Bookshelf [ncbi.nlm.nih.gov]
- 3. Author Guidelines [researcher-resources.acs.org]
- 4. Cellular responses and functions of  $\alpha 7$  nicotinic acetylcholine receptor activation in the brain: a narrative review - Xu - Annals of Translational Medicine [atm.amegroups.org]
- To cite this document: BenchChem. [Structure-activity relationship of BNC375 and its analogs]. BenchChem, [2025]. [Online PDF]. Available at: [https://www.benchchem.com/product/b8107612#structure-activity-relationship-of-bnc375-and-its-analogs]

---

### Disclaimer & Data Validity:

The information provided in this document is for Research Use Only (RUO) and is strictly not intended for diagnostic or therapeutic procedures. While BenchChem strives to provide accurate protocols, we make no warranties, express or implied, regarding the fitness of this product for every specific experimental setup.

**Technical Support:** The protocols provided are for reference purposes. Unsure if this reagent suits your experiment? [[Contact our Ph.D. Support Team for a compatibility check](#)]

**Need Industrial/Bulk Grade?** [Request Custom Synthesis Quote](#)

# BenchChem

Our mission is to be the trusted global source of essential and advanced chemicals, empowering scientists and researchers to drive progress in science and industry.

## Contact

Address: 3281 E Guasti Rd

Ontario, CA 91761, United States

Phone: (601) 213-4426

Email: [info@benchchem.com](mailto:info@benchchem.com)