

Strategies to reduce off-target effects of Asclepin in cellular models.

Author: BenchChem Technical Support Team. **Date:** December 2025

Compound of Interest

Compound Name: *Asclepin*

Cat. No.: *B1195515*

[Get Quote](#)

Technical Support Center: Asclepin

Welcome to the **Asclepin** Technical Support Center. This resource is designed to assist researchers, scientists, and drug development professionals in utilizing **Asclepin** effectively in cellular models. Here you will find troubleshooting guides and frequently asked questions (FAQs) to address common issues, particularly regarding the off-target effects of **Asclepin**.

Frequently Asked Questions (FAQs)

Q1: What is the primary mechanism of action of **Asclepin**?

A1: **Asclepin** is a cardenolide glycoside, and its primary mechanism of action is the inhibition of the plasma membrane Na⁺/K⁺-ATPase (sodium-potassium pump).[1][2][3] This inhibition leads to an increase in intracellular sodium ion concentration. Consequently, the sodium-calcium exchanger (NCX) reverses its direction, causing an influx of calcium ions and an increase in intracellular calcium levels.[3] In cardiac muscle cells, this increase in intracellular calcium enhances contractility.[4]

Q2: What are the potential off-target effects of **Asclepin** in cellular models?

A2: While the primary target of **Asclepin** is the Na⁺/K⁺-ATPase, its inhibition can trigger a cascade of downstream signaling events that may be considered off-target effects in non-cardiac research contexts. These can include:

- Activation of Src kinase and downstream pathways: Binding of cardiac glycosides to Na⁺/K⁺-ATPase can initiate signal transduction cascades involving Src, a non-receptor tyrosine kinase, leading to the activation of pathways like MAPK/ERK.[5]
- Induction of Reactive Oxygen Species (ROS): **Asclepin** treatment can lead to the generation of ROS, which can induce cellular stress and activate various signaling pathways.[6][7]
- Modulation of NF-κB signaling: Some cardiac glycosides have been shown to inhibit the TNF-α/NF-κB signaling pathway, which is a key regulator of inflammation and cell survival.[8][9]
- Inhibition of general protein synthesis: At higher concentrations, cardiac glycosides can lead to a general inhibition of protein synthesis, which can contribute to cytotoxicity.[10][11]
- Induction of immunogenic cell death (ICD): In cancer cell models, **Asclepin** may induce ICD, characterized by the release of damage-associated molecular patterns (DAMPs).[12][13]

Q3: Why do I observe different sensitivities to **Asclepin** in different cell lines?

A3: Cellular sensitivity to **Asclepin** and other cardiac glycosides can vary significantly due to several factors:

- Species of origin: Rodent cell lines are known to be more resistant to cardiac glycosides compared to human cell lines due to differences in the Na⁺/K⁺-ATPase α-subunit.[11][14]
- Expression levels of Na⁺/K⁺-ATPase isoforms: Different isoforms of the Na⁺/K⁺-ATPase α-subunit (α1, α2, α3) have varying affinities for cardiac glycosides.[15] The relative expression of these isoforms in a given cell line will influence its sensitivity.
- Cellular context and signaling pathways: The downstream signaling pathways and compensatory mechanisms present in a particular cell type can modulate the ultimate response to **Asclepin**. [16]

Troubleshooting Guide

Issue 1: High cytotoxicity observed in my cellular model at expected therapeutic concentrations.

This could be due to on-target effects leading to cellular toxicity in non-cardiac cells or off-target effects.

Troubleshooting Steps	Detailed Methodology
1. Optimize Asclepin Concentration	Perform a dose-response curve to determine the optimal, non-toxic concentration range for your specific cell line and experimental endpoint. Start with a broad range of concentrations (e.g., 1 nM to 10 μ M) and narrow down to a working concentration that elicits the desired on-target effect with minimal cytotoxicity.
2. Reduce Incubation Time	Shorter incubation times may be sufficient to observe the desired on-target effect while minimizing cytotoxicity. Perform a time-course experiment (e.g., 6, 12, 24, 48 hours) at a fixed, optimized concentration of Asclepin.
3. Use a Control Compound	Utilize a structurally related but inactive analog of Asclepin, if available. Alternatively, use a well-characterized cardiac glycoside with a known off-target profile (e.g., digoxin) for comparison.
4. Confirm On-Target Engagement	Use a target engagement assay, such as the Cellular Thermal Shift Assay (CETSA), to confirm that Asclepin is binding to the Na ⁺ /K ⁺ -ATPase in your cells at the concentrations used. [16]

Issue 2: Inconsistent or unexpected experimental results.

This may be due to the activation of off-target signaling pathways.

Troubleshooting Steps	Detailed Methodology
1. Profile Off-Target Signaling	Investigate the activation of known cardiac glycoside-induced signaling pathways. Use western blotting or other immunoassays to probe for the phosphorylation of key signaling proteins such as Src, ERK, and components of the NF- κ B pathway.
2. Measure ROS Production	Quantify the generation of reactive oxygen species using fluorescent probes like DCFDA (2',7'-dichlorofluorescein diacetate) and flow cytometry or a plate reader.
3. Use Pathway-Specific Inhibitors	To dissect the contribution of off-target signaling, co-treat cells with Asclepin and specific inhibitors of suspected off-target pathways (e.g., a Src kinase inhibitor like Saracatinib).
4. Employ a Resistant Cell Line	As a negative control, use a rodent cell line known to be resistant to cardiac glycosides to differentiate between on-target and off-target effects. ^[14] Alternatively, if feasible, generate a cell line expressing a cardiac glycoside-resistant mutant of the Na ⁺ /K ⁺ -ATPase. ^[13]

Quantitative Data Summary

Table 1: General Concentration Ranges of Cardiac Glycosides in Cellular Models

Compound	Cell Line Type	Effective Concentration Range	Observed Effects	Reference
Digoxin	Human cancer cell lines	10 nM - 1 μ M	Apoptosis, cell cycle arrest, NF- κ B inhibition	[9]
Ouabain	Cardiac myocytes	10 nM - 100 μ M	Increased intracellular Ca ²⁺ , ROS generation	[6][7]
Digitoxin	Human cancer cell lines	1 nM - 1 μ M	Inhibition of protein synthesis, cytotoxicity	[10]
Asclepin	DU145 (prostate cancer)	IC50 values vary by derivative	Cytotoxicity, Na ⁺ /K ⁺ -ATPase inhibition	[17]

Note: These are general ranges. The optimal concentration for **Asclepin** must be determined empirically for each specific cellular model and experimental endpoint.

Experimental Protocols

Protocol 1: Determining Asclepin Cytotoxicity using MTT Assay

- Cell Seeding: Seed cells in a 96-well plate at a density of 5,000-10,000 cells per well and allow them to adhere overnight.
- Compound Treatment: Prepare serial dilutions of **Asclepin** in cell culture medium. Remove the old medium from the cells and add 100 μ L of the **Asclepin**-containing medium to each well. Include a vehicle control (e.g., DMSO).

- Incubation: Incubate the plate for the desired time period (e.g., 24, 48, or 72 hours) at 37°C in a humidified incubator with 5% CO₂.
- MTT Addition: Add 10 µL of MTT solution (5 mg/mL in PBS) to each well and incubate for 2-4 hours at 37°C until formazan crystals are visible.
- Solubilization: Carefully remove the medium and add 100 µL of DMSO or another suitable solvent to each well to dissolve the formazan crystals.
- Measurement: Measure the absorbance at 570 nm using a microplate reader.
- Data Analysis: Calculate cell viability as a percentage of the vehicle control and plot the dose-response curve to determine the IC₅₀ value.

Protocol 2: Cellular Thermal Shift Assay (CETSA) for Target Engagement

- Cell Treatment: Treat cultured cells with either vehicle or the desired concentration of **Asclepin** and incubate to allow for target binding.
- Heating Step: Aliquot the cell suspension into PCR tubes and heat them to a range of different temperatures (e.g., 40°C to 70°C) for 3 minutes to induce protein denaturation.
- Cell Lysis: Lyse the cells by freeze-thawing.
- Separation of Fractions: Centrifuge the lysates at high speed (e.g., 20,000 x g) to pellet the aggregated, denatured proteins.
- Protein Analysis: Collect the supernatant containing the soluble proteins and analyze the levels of Na⁺/K⁺-ATPase by western blotting or another suitable method.
- Data Analysis: Increased thermal stability of Na⁺/K⁺-ATPase in the **Asclepin**-treated samples compared to the vehicle control indicates target engagement.

Visualizations

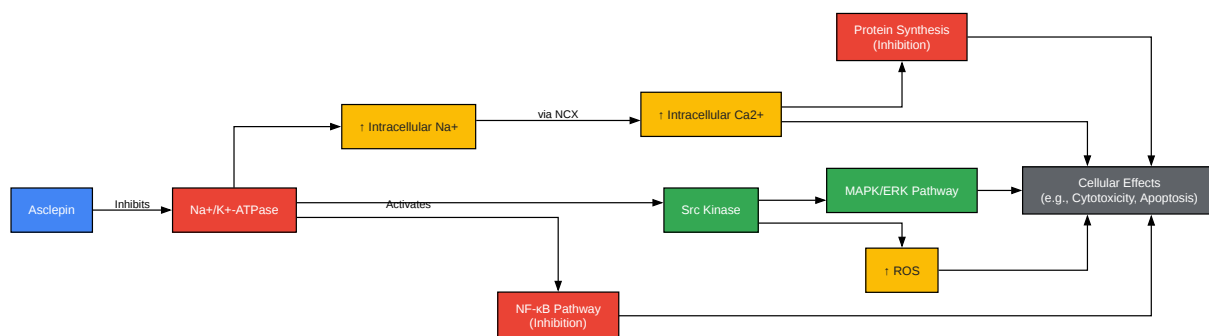

[Click to download full resolution via product page](#)

Caption: Potential signaling pathways modulated by **Asclepin**.

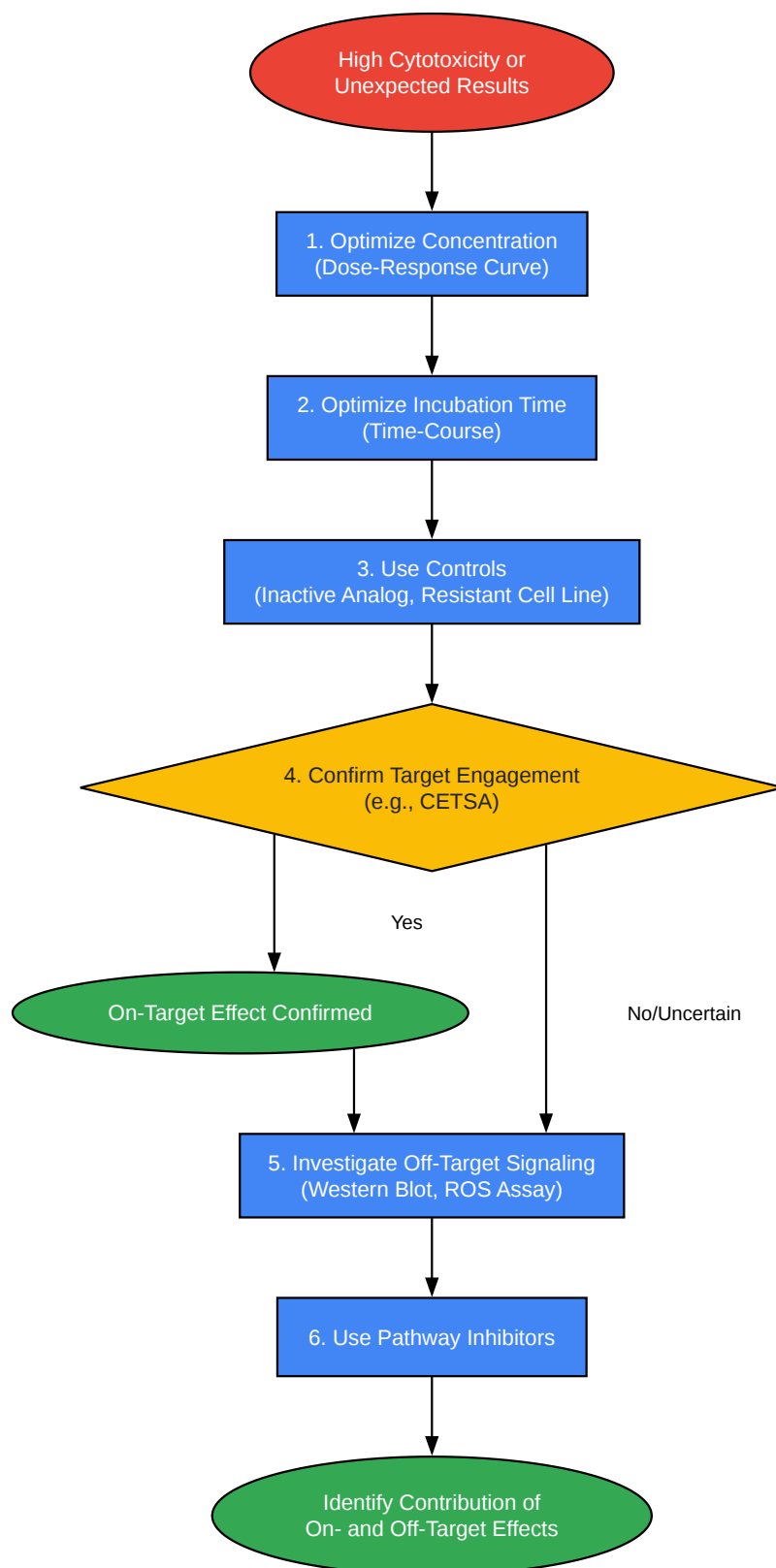

[Click to download full resolution via product page](#)

Caption: Troubleshooting workflow for **Asclepin** experiments.

Need Custom Synthesis?

BenchChem offers custom synthesis for rare earth carbides and specific isotopic labeling.

Email: info@benchchem.com or [Request Quote Online](#).

References

- 1. Cardiac glycoside - Wikipedia [en.wikipedia.org]
- 2. derangedphysiology.com [derangedphysiology.com]
- 3. Quo vadis Cardiac Glycoside Research? - PMC [pmc.ncbi.nlm.nih.gov]
- 4. m.youtube.com [m.youtube.com]
- 5. Frontiers | Ouabain-Induced Cell Death and Survival. Role of α 1-Na,K-ATPase-Mediated Signaling and $[Na^+]_i/[K^+]_i$ -Dependent Gene Expression [frontiersin.org]
- 6. "Ouabain Interaction with Cardiac Na^+/K^+ -ATPase Initiates Signal Cascad" by Jiang Liu, Jiang Tian et al. [mds.marshall.edu]
- 7. files.core.ac.uk [files.core.ac.uk]
- 8. Cardiac glycosides inhibit TNF- α /NF- κ B signaling by blocking recruitment of TNF receptor-associated death domain to the TNF receptor - PMC [pmc.ncbi.nlm.nih.gov]
- 9. Effects of digoxin on cell cycle, apoptosis and NF- κ B pathway in Burkitt's lymphoma cells and animal model - PubMed [pubmed.ncbi.nlm.nih.gov]
- 10. Cardiac Glycosides Induce Cell Death in Human Cells by Inhibiting General Protein Synthesis | PLOS One [journals.plos.org]
- 11. Cardiac glycosides induce cell death in human cells by inhibiting general protein synthesis - PubMed [pubmed.ncbi.nlm.nih.gov]
- 12. Cardiac glycosides: Looking beyond heart failure and atrial fibrillation - PMC [pmc.ncbi.nlm.nih.gov]
- 13. Anticancer activity of cardiac glycosides: At the frontier between cell-autonomous and immunological effects - PMC [pmc.ncbi.nlm.nih.gov]
- 14. Cellular basis for the species differences in sensitivity to cardiac glycosides (digitalis) - PubMed [pubmed.ncbi.nlm.nih.gov]
- 15. mdpi.com [mdpi.com]
- 16. benchchem.com [benchchem.com]

- 17. Structures, chemotaxonomic significance, cytotoxic and Na(+),K(+)-ATPase inhibitory activities of new cardenolides from *Asclepias curassavica* - PubMed [pubmed.ncbi.nlm.nih.gov]
- To cite this document: BenchChem. [Strategies to reduce off-target effects of Asclepin in cellular models.]. BenchChem, [2025]. [Online PDF]. Available at: [https://www.benchchem.com/product/b1195515#strategies-to-reduce-off-target-effects-of-asclepin-in-cellular-models]

Disclaimer & Data Validity:

The information provided in this document is for Research Use Only (RUO) and is strictly not intended for diagnostic or therapeutic procedures. While BenchChem strives to provide accurate protocols, we make no warranties, express or implied, regarding the fitness of this product for every specific experimental setup.

Technical Support: The protocols provided are for reference purposes. Unsure if this reagent suits your experiment? [[Contact our Ph.D. Support Team for a compatibility check](#)]

Need Industrial/Bulk Grade? [Request Custom Synthesis Quote](#)

BenchChem

Our mission is to be the trusted global source of essential and advanced chemicals, empowering scientists and researchers to drive progress in science and industry.

Contact

Address: 3281 E Guasti Rd
Ontario, CA 91761, United States
Phone: (601) 213-4426
Email: info@benchchem.com