

# Standard Operating Procedure for Fluorescence Spectroscopy of Benzoxazoles

**Author:** BenchChem Technical Support Team. **Date:** December 2025

## Compound of Interest

Compound Name: *Fluorescent Brightener 135*

Cat. No.: *B090793*

[Get Quote](#)

## Application Note & Protocol

Audience: Researchers, scientists, and drug development professionals.

### Introduction

Benzoxazoles are a class of heterocyclic compounds that are of significant interest in pharmaceutical and materials science due to their diverse biological activities and unique photophysical properties.<sup>[1]</sup> Many benzoxazole derivatives exhibit strong fluorescence, making them valuable as fluorescent probes, molecular sensors, and imaging agents.<sup>[2][3]</sup> Their fluorescence characteristics are often sensitive to the local environment, which can be exploited for various applications, including DNA probing and sensing of metal ions.<sup>[3][4]</sup> This document provides a detailed standard operating procedure (SOP) for the fluorescence spectroscopy of benzoxazoles, covering sample preparation, instrumentation, data acquisition, and analysis.

## Data Presentation: Photophysical Properties of Benzoxazole Derivatives

The following tables summarize the key photophysical properties of selected benzoxazole derivatives from the literature. These values are dependent on the specific molecular structure and solvent used.

Table 1: Absorption and Emission Properties of Selected Benzoxazole Derivatives.

Compound/ Derivative	Solvent	Absorption Max ( $\lambda_{abs}$ , nm)	Emission Max ( $\lambda_{em}$ , nm)	Stokes Shift (nm)	Reference
2-(2'-Hydroxyphenyl)benzoxazole (HBO)	Various	~330-360	~430-530	~100-170	[5]
Benzoxazolyl-imidazole Conjugate (6a)	DMSO	470	-	-	[6]
Benzothiazolyl-imidazole Conjugate (6b)	DMSO	475	-	-	[6]
2-(2',4'-Dihydroxyphenyl)benzoxazole	DMF	360	452	92	[5]
2-(Furan-2-YL)phenol Derivative	Not Specified	Not Available	Not Available	Not Available	[7]
Nitrobenzoxazole Derivatives	Various	~460-480	~530-550	~70-90	[8]

Table 2: Fluorescence Quantum Yields of Selected Benzoxazole Derivatives.

Compound/ Derivative	Solvent	Excitation Wavelength (nm)	Quantum Yield ( $\Phi_F$ )	Standard Used	Reference
2,6- di(benzo[d]ox azol-2-yl) pyridine	Chloroform	358	0.0039	Fluorescein	[5]
3- (benzo[d]oxa zol-2-yl) naphthalen-2- ol	Chloroform	370	0.0019	Fluorescein	[5]
Quinine Sulfate (Standard)	0.1 M H <sub>2</sub> SO <sub>4</sub>	372	0.54	-	[9]
Quinine Sulfate (Standard)	0.05 M H <sub>2</sub> SO <sub>4</sub>	310	0.546	-	[7]

## Experimental Protocols

### Sample Preparation

Proper sample preparation is critical for obtaining high-quality fluorescence data.[10]

#### 2.1.1. Materials

- Benzoxazole derivative (solid or stock solution)
- Spectroscopic grade solvents (e.g., DMSO, ethanol, chloroform, cyclohexane)[5][8]
- Volumetric flasks and pipettes
- Quartz cuvettes (1 cm path length)[7]

#### 2.1.2. Procedure for Solution-State Measurements

- **Solvent Selection:** Choose a solvent that dissolves the benzoxazole derivative and is transparent in the desired excitation and emission wavelength range. The solvent can influence the photophysical properties of the compound.[8]
- **Stock Solution Preparation:** Accurately weigh a small amount of the benzoxazole derivative and dissolve it in the chosen solvent to prepare a stock solution of known concentration (e.g., 1 mM).
- **Working Solution Preparation:** Prepare a series of dilutions from the stock solution. For standard fluorescence measurements, the absorbance of the solution at the excitation wavelength should be kept below 0.1 to avoid inner filter effects.[11] A typical concentration range is 1-10  $\mu\text{M}$ .
- **Cuvette Preparation:** Clean the quartz cuvette thoroughly. Rinse it with the solvent before filling it with the sample solution. Ensure there are no air bubbles in the cuvette.

## Instrumentation and Setup

A standard spectrofluorometer is used for these measurements.[12][13]

### 2.2.1. Instrument Components

- **Light Source:** Typically a Xenon arc lamp.[12]
- **Excitation and Emission Monochromators:** To select the excitation wavelength and scan the emission spectrum.[12]
- **Sample Holder:** A temperature-controlled cuvette holder.
- **Detector:** A photomultiplier tube (PMT).[14]

### 2.2.2. Instrument Parameters

The following are typical starting parameters that may need to be optimized for specific compounds and concentrations:

- **Excitation Wavelength ( $\lambda_{\text{ex}}$ ):** This is typically set to the absorption maximum ( $\lambda_{\text{abs}}$ ) of the benzoxazole derivative.

- Emission Wavelength Range: Scan a range that covers the expected fluorescence emission of the compound (e.g., 350-700 nm).
- Excitation and Emission Slit Widths: A common starting point is 5 nm for both. Narrower slits provide better resolution but less signal, while wider slits increase the signal but decrease resolution.[\[9\]](#)[\[15\]](#)
- Scan Speed: A moderate scan speed (e.g., 100-500 nm/min) is usually sufficient.[\[9\]](#)
- Detector Voltage: Adjust as needed to obtain a good signal-to-noise ratio without saturating the detector.

## Data Acquisition

- Blank Measurement: Record the emission spectrum of the pure solvent in the cuvette. This will be subtracted from the sample spectra to correct for solvent Raman scattering and other background signals.
- Sample Measurement: Record the emission spectrum of the benzoxazole solution.
- Excitation Spectrum (Optional): To confirm the identity of the absorbing species that is responsible for the fluorescence, an excitation spectrum can be recorded. Set the emission monochromator to the wavelength of maximum fluorescence and scan a range of excitation wavelengths. The resulting excitation spectrum should resemble the absorption spectrum of the compound.[\[13\]](#)

## Determination of Relative Fluorescence Quantum Yield ( $\Phi_F$ )

The fluorescence quantum yield is a measure of the efficiency of the fluorescence process. The comparative method using a well-characterized standard is the most common approach.[\[7\]](#) Quinine sulfate in 0.1 M H<sub>2</sub>SO<sub>4</sub> ( $\Phi_F = 0.54$ ) or 0.05 M H<sub>2</sub>SO<sub>4</sub> ( $\Phi_F = 0.546$ ) is a common standard.[\[7\]](#)[\[9\]](#)

### 2.4.1. Procedure

- Prepare a series of dilutions of both the benzoxazole sample and the quinine sulfate standard with absorbances ranging from 0.01 to 0.1 at the excitation wavelength.
- Measure the UV-Vis absorption spectra of all solutions.
- Measure the fluorescence emission spectra of all solutions, ensuring the excitation wavelength is the same for both the sample and the standard.
- Integrate the area under the emission curves for both the sample and the standard solutions.
- Plot the integrated fluorescence intensity versus absorbance for both the sample and the standard. The plots should be linear.
- Calculate the quantum yield of the sample ( $\Phi_{F\_sample}$ ) using the following equation:

$$\Phi_{F\_sample} = \Phi_{F\_std} * (m_{sample} / m_{std}) * (\eta_{sample}^2 / \eta_{std}^2)$$

Where:

- $\Phi_{F\_std}$  is the known quantum yield of the standard.[7]
- $m_{sample}$  and  $m_{std}$  are the slopes from the plots of integrated fluorescence intensity vs. absorbance for the sample and standard, respectively.[7]
- $\eta_{sample}$  and  $\eta_{std}$  are the refractive indices of the solvents used for the sample and the standard, respectively.[7]

## Mandatory Visualizations

### Experimental Workflow for Benzoxazoles as Fluorescent DNA Probes

Benzoxazole derivatives can act as fluorescent probes for DNA, often exhibiting enhanced fluorescence upon binding.[3][4] The following workflow illustrates the experimental process.

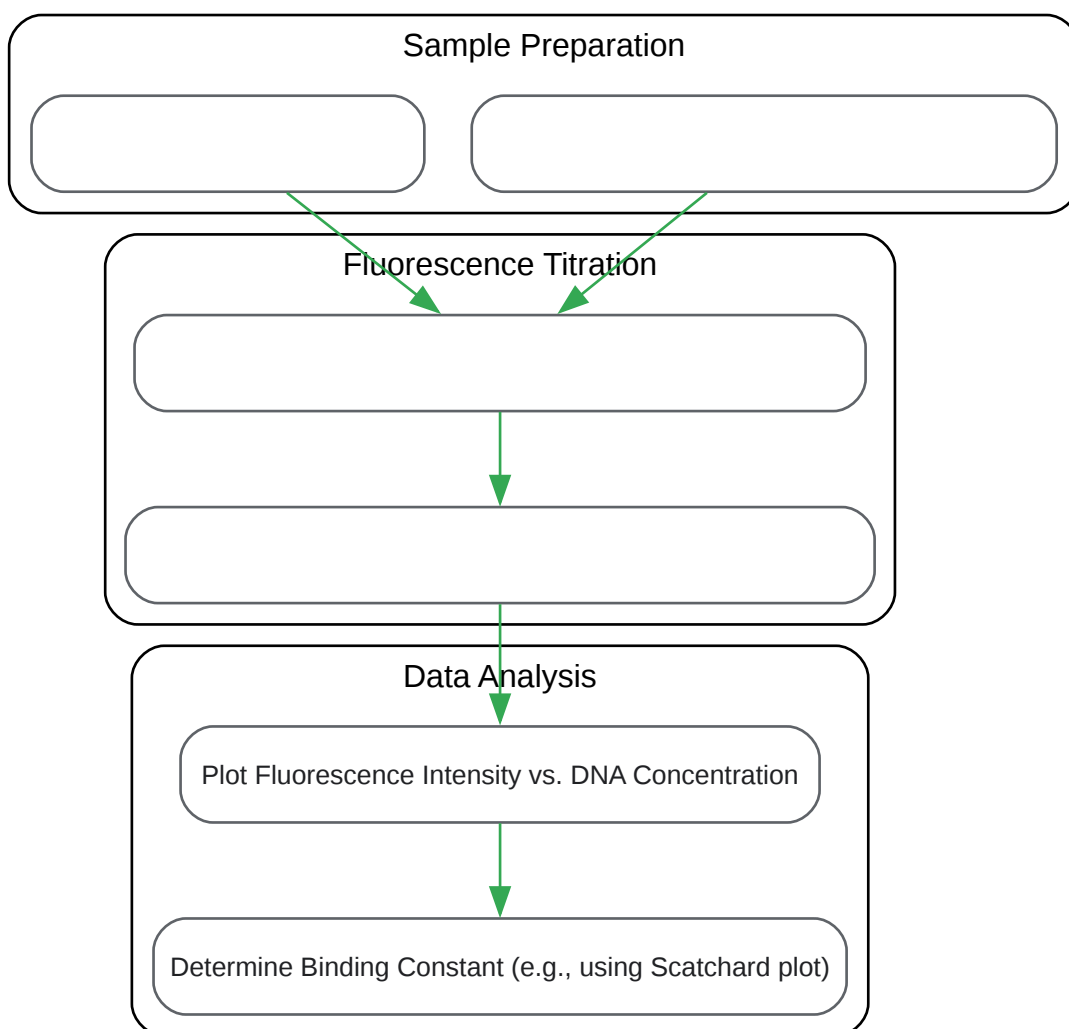

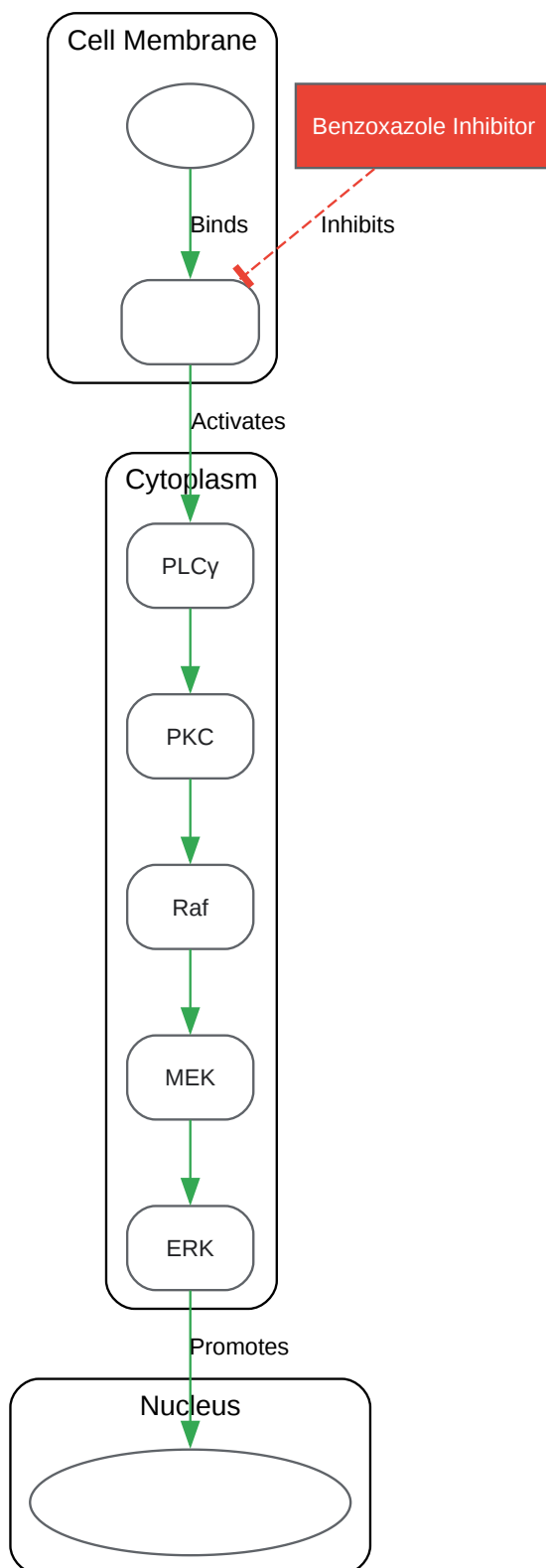

[Click to download full resolution via product page](#)



**Need Custom Synthesis?**

BenchChem offers custom synthesis for rare earth carbides and specific isotopic labeling.

Email: [info@benchchem.com](mailto:info@benchchem.com) or [Request Quote Online](#).

## References

- 1. scribd.com [scribd.com]
- 2. researchgate.net [researchgate.net]
- 3. biori.periodikos.com.br [biori.periodikos.com.br]
- 4. Naphthoxazole and benzoxazole as fluorescent DNA probes  a systematic review [biori.periodikos.com.br]
- 5. chem.uaic.ro [chem.uaic.ro]
- 6. Synthesis and photophysical properties of benzoxazolyl-imidazole and benzothiazolyl-imidazole conjugates - RSC Advances (RSC Publishing) DOI:10.1039/D1RA08342B [pubs.rsc.org]
- 7. benchchem.com [benchchem.com]
- 8. benchchem.com [benchchem.com]
- 9. pubs.rsc.org [pubs.rsc.org]
- 10. academic.oup.com [academic.oup.com]
- 11. kulturkaufhaus.de [kulturkaufhaus.de]
- 12. hinotek.com [hinotek.com]
- 13. Fluorescence spectroscopy - Wikipedia [en.wikipedia.org]
- 14. agilent.com [agilent.com]
- 15. scibec.dcci.unipi.it [scibec.dcci.unipi.it]
- To cite this document: BenchChem. [Standard Operating Procedure for Fluorescence Spectroscopy of Benzoxazoles]. BenchChem, [2025]. [Online PDF]. Available at: [https://www.benchchem.com/product/b090793#standard-operating-procedure-for-fluorescence-spectroscopy-of-benzoxazoles]

---

**Disclaimer & Data Validity:**

The information provided in this document is for Research Use Only (RUO) and is strictly not intended for diagnostic or therapeutic procedures. While BenchChem strives to provide accurate protocols, we make no warranties, express or implied, regarding the fitness of this product for every specific experimental setup.

**Technical Support:** The protocols provided are for reference purposes. Unsure if this reagent suits your experiment? [[Contact our Ph.D. Support Team for a compatibility check](#)]

**Need Industrial/Bulk Grade?** [Request Custom Synthesis Quote](#)

## BenchChem

Our mission is to be the trusted global source of essential and advanced chemicals, empowering scientists and researchers to drive progress in science and industry.

### Contact

Address: 3281 E Guasti Rd  
Ontario, CA 91761, United States  
Phone: (601) 213-4426  
Email: [info@benchchem.com](mailto:info@benchchem.com)