

Stability testing of 2-Isopropyl-1-methoxy-4-nitrobenzene in different solvents

Author: BenchChem Technical Support Team. **Date:** December 2025

Compound of Interest

Compound Name: *2-Isopropyl-1-methoxy-4-nitrobenzene*

Cat. No.: *B157884*

[Get Quote](#)

Technical Support Center: Stability of 2-Isopropyl-1-methoxy-4-nitrobenzene

This technical support center provides troubleshooting guidance and frequently asked questions (FAQs) for researchers, scientists, and drug development professionals working with **2-isopropyl-1-methoxy-4-nitrobenzene**. The information is designed to address common challenges encountered during stability testing in various solvents.

Troubleshooting Guide

Issue	Potential Cause	Recommended Action
Unexpected Degradation in Aprotic Solvents (e.g., Acetonitrile, THF)	Trace water content catalyzing hydrolysis.	Use freshly distilled or anhydrous grade solvents. Store solvents over molecular sieves.
Photodegradation from ambient light.	Protect solutions from light by using amber vials or covering glassware with aluminum foil.	
Rapid Degradation in Protic Solvents (e.g., Methanol, Ethanol)	Solvolysis (reaction with the solvent).	Consider using a less reactive, aprotic solvent if compatible with the experimental design. If a protic solvent is necessary, conduct experiments at a lower temperature to reduce the reaction rate.
Presence of acidic or basic impurities.	Use high-purity solvents and consider buffering the solution if the compound is sensitive to pH.	
Inconsistent Results in HPLC Analysis	Poor peak shape or retention time shifts.	Ensure proper column equilibration. Check for solvent mismatch between the sample and the mobile phase. Verify the pH of the mobile phase.
Appearance of unknown peaks over time.	This likely indicates degradation. Perform forced degradation studies (see Experimental Protocols) to intentionally generate and identify degradation products. Use a photodiode array (PDA) detector to check for peak purity.	

Difficulty in Quantifying
Degradation Products

Low concentration of
degradants.

Use a more sensitive analytical
technique such as LC-MS.
Concentrate the sample if
possible, ensuring the
concentration method does not
induce further degradation.

Co-elution of degradants with
the parent compound.

Optimize the HPLC method by
changing the mobile phase
composition, gradient, column
chemistry, or temperature.

Frequently Asked Questions (FAQs)

Q1: What are the expected degradation pathways for **2-isopropyl-1-methoxy-4-nitrobenzene**?

A1: Based on the structure, potential degradation pathways include:

- Hydrolysis of the methoxy group: This can occur under acidic or basic conditions, leading to the formation of 2-isopropyl-4-nitrophenol.
- Reduction of the nitro group: This is possible in the presence of reducing agents and can lead to the formation of corresponding nitroso, hydroxylamino, and amino derivatives.
- Oxidation of the isopropyl group: Strong oxidizing conditions could potentially lead to the formation of various oxidation products.

Q2: How does pH affect the stability of **2-isopropyl-1-methoxy-4-nitrobenzene** in aqueous solutions?

A2: Stability in aqueous solutions is expected to be pH-dependent. Generally, aromatic ethers can be susceptible to hydrolysis under strongly acidic or basic conditions. It is advisable to conduct stability studies across a range of pH values (e.g., pH 3, 7, and 9) to determine the optimal pH for stability.^[1]

Q3: What analytical techniques are most suitable for stability testing of this compound?

A3: High-Performance Liquid Chromatography (HPLC) with UV detection is a common and effective method for quantifying the parent compound and its degradation products.[2] For the identification of unknown degradants, hyphenated techniques like Liquid Chromatography-Mass Spectrometry (LC-MS) are highly recommended.[2][3] Nuclear Magnetic Resonance (NMR) spectroscopy can also be used for the structural elucidation of isolated degradation products.[2]

Q4: How should I prepare samples for a forced degradation study?

A4: Forced degradation studies involve exposing the compound to stress conditions to accelerate degradation.[3] A typical study would involve separate experiments where the compound is subjected to:

- Acidic conditions: e.g., 0.1 M HCl at a controlled temperature.
- Basic conditions: e.g., 0.1 M NaOH at a controlled temperature.
- Oxidative conditions: e.g., 3% H₂O₂ at a controlled temperature.
- Thermal stress: Heating the solid compound or a solution.
- Photolytic stress: Exposing the compound in solution to UV and visible light.

Samples should be taken at various time points and analyzed by a stability-indicating HPLC method.

Experimental Protocols

Protocol 1: HPLC Method for Stability Indicating Assay

This protocol outlines a general reverse-phase HPLC method suitable for separating **2-isopropyl-1-methoxy-4-nitrobenzene** from its potential degradation products.

- Column: C18, 4.6 x 150 mm, 5 µm
- Mobile Phase A: 0.1% Formic acid in Water
- Mobile Phase B: Acetonitrile

- Gradient:
 - 0-2 min: 40% B
 - 2-15 min: 40% to 90% B
 - 15-18 min: 90% B
 - 18-18.1 min: 90% to 40% B
 - 18.1-25 min: 40% B
- Flow Rate: 1.0 mL/min
- Column Temperature: 30 °C
- Detection Wavelength: 254 nm
- Injection Volume: 10 µL
- Sample Preparation: Dissolve the sample in acetonitrile or a mixture of acetonitrile and water to a final concentration of approximately 1 mg/mL.

Protocol 2: Forced Degradation Study in Solution

- Prepare Stock Solution: Prepare a 10 mg/mL stock solution of **2-isopropyl-1-methoxy-4-nitrobenzene** in acetonitrile.
- Prepare Stress Solutions:
 - Acidic: Dilute the stock solution 1:10 in 0.1 M HCl.
 - Basic: Dilute the stock solution 1:10 in 0.1 M NaOH.
 - Oxidative: Dilute the stock solution 1:10 in 3% H₂O₂.
 - Control: Dilute the stock solution 1:10 in the chosen study solvent (e.g., a 50:50 mixture of acetonitrile and water).

- Incubation: Incubate all solutions in a controlled temperature bath (e.g., 60 °C). Protect from light unless photostability is being tested.
- Time Points: Withdraw aliquots at initial (t=0), 2, 4, 8, and 24 hours.
- Sample Quenching:
 - For acidic samples, neutralize with an equivalent amount of 0.1 M NaOH.
 - For basic samples, neutralize with an equivalent amount of 0.1 M HCl.
- Analysis: Analyze all samples by the stability-indicating HPLC method (Protocol 1).

Data Presentation

Table 1: Hypothetical Stability of **2-Isopropyl-1-methoxy-4-nitrobenzene** in Different Solvents at 40°C over 48 hours

Solvent	% Remaining Parent Compound (24h)	% Remaining Parent Compound (48h)	Major Degradation Product(s)
Acetonitrile	98.5	97.2	Minor unknown peaks
Methanol	92.1	85.4	2-isopropyl-4-nitrophenol
Dichloromethane	99.2	98.8	None detected
Water (pH 7)	96.3	92.5	2-isopropyl-4-nitrophenol
0.1 M HCl	85.7	74.1	2-isopropyl-4-nitrophenol
0.1 M NaOH	78.2	61.9	Multiple degradation products

Table 2: Summary of Forced Degradation Studies

Stress Condition	Duration	% Degradation	Number of Degradation Products
0.1 M HCl, 60°C	24h	~15%	1
0.1 M NaOH, 60°C	24h	~38%	>3
3% H ₂ O ₂ , 60°C	24h	~8%	2
Thermal, 80°C	48h	<5%	1
Photolytic (UV/Vis)	24h	~12%	2

Visualizations

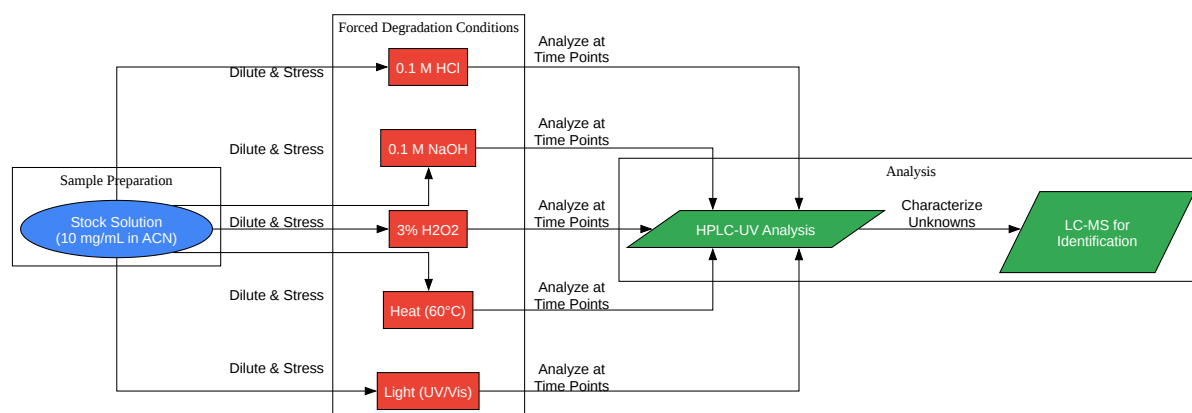

[Click to download full resolution via product page](#)

Caption: Workflow for forced degradation studies.

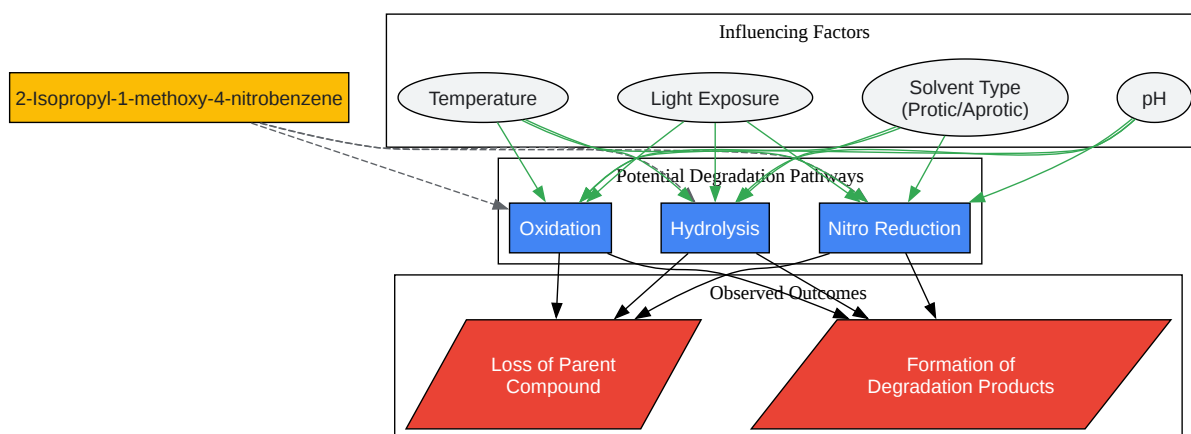

[Click to download full resolution via product page](#)

Caption: Factors influencing compound stability.

Need Custom Synthesis?

BenchChem offers custom synthesis for rare earth carbides and specific isotopic labeling.

Email: info@benchchem.com or [Request Quote Online](#).

References

- 1. 2-Isopropyl-1-methoxy-4-methylbenzene | 31574-44-4 | Benchchem [[benchchem.com](https://www.benchchem.com)]
- 2. Analytical Techniques In Stability Testing | Separation Science [[sepscience.com](https://www.sepscience.com)]

- 3. pharमतutor.org [pharमतutor.org]
- To cite this document: BenchChem. [Stability testing of 2-Isopropyl-1-methoxy-4-nitrobenzene in different solvents]. BenchChem, [2025]. [Online PDF]. Available at: [https://www.benchchem.com/product/b157884#stability-testing-of-2-isopropyl-1-methoxy-4-nitrobenzene-in-different-solvents]

Disclaimer & Data Validity:

The information provided in this document is for Research Use Only (RUO) and is strictly not intended for diagnostic or therapeutic procedures. While BenchChem strives to provide accurate protocols, we make no warranties, express or implied, regarding the fitness of this product for every specific experimental setup.

Technical Support: The protocols provided are for reference purposes. Unsure if this reagent suits your experiment? [[Contact our Ph.D. Support Team for a compatibility check](#)]

Need Industrial/Bulk Grade? [Request Custom Synthesis Quote](#)

BenchChem

Our mission is to be the trusted global source of essential and advanced chemicals, empowering scientists and researchers to drive progress in science and industry.

Contact

Address: 3281 E Guasti Rd
Ontario, CA 91761, United States
Phone: (601) 213-4426
Email: info@benchchem.com