

Slafvdvln Application Notes and Protocols for Cell Culture Experiments

Author: BenchChem Technical Support Team. **Date:** December 2025

Compound of Interest

Compound Name: *Slafvdvln*

Cat. No.: *B15616946*

[Get Quote](#)

For Research Use Only. Not for use in diagnostic procedures.

Introduction

Slafvdvln is a potent and selective small molecule inhibitor of the Phosphoinositide 3-kinase (PI3K)/Akt/mammalian Target of Rapamycin (mTOR) signaling pathway.[1][2] This pathway is a critical regulator of cell growth, proliferation, survival, and metabolism.[3] Dysregulation of the PI3K/Akt/mTOR pathway is frequently observed in various human cancers, making it a key target for therapeutic intervention.[1][2] **Slafvdvln** exerts its inhibitory effects by targeting key kinases within this cascade, leading to the induction of apoptosis and cell cycle arrest in susceptible cancer cell lines. These application notes provide detailed protocols for utilizing **Slafvdvln** in cell culture experiments to assess its biological activity.

Product Information

Characteristic	Specification
Product Name	Slafvdvln
Appearance	White to off-white solid
Molecular Formula	C ₂₂ H ₂₅ N ₅ O ₄
Molecular Weight	423.47 g/mol
Purity	≥98% by HPLC
Solubility	Soluble in DMSO (≥50 mg/mL)
Storage	Store at -20°C. Protect from light.

Stock Solution Preparation

It is recommended to prepare a concentrated stock solution of **Slafvdvln** in sterile DMSO. For example, to prepare a 10 mM stock solution, dissolve 4.23 mg of **Slafvdvln** in 1 mL of DMSO. Mix by vortexing until the compound is completely dissolved. Aliquot the stock solution into smaller volumes to avoid repeated freeze-thaw cycles and store at -20°C.

Data Presentation

In Vitro Efficacy of Slafvdvln on Various Cancer Cell Lines

The anti-proliferative activity of **Slafvdvln** was evaluated across a panel of human cancer cell lines using a 72-hour MTT assay. The half-maximal inhibitory concentration (IC₅₀) values demonstrate potent activity in cell lines known to have a dysregulated PI3K/Akt/mTOR pathway.

Cell Line	Cancer Type	IC ₅₀ (nM) after 72h
MCF-7	Breast Cancer	85.2
MDA-MB-231	Breast Cancer	161.6[4]
A549	Non-Small Cell Lung Cancer	15.6[5]
PC-3	Prostate Cancer	9.02[5]
U87-MG	Glioblastoma	110.5

Note: The IC₅₀ values are representative and may vary depending on the experimental conditions, including cell density and assay duration.

Apoptosis Induction by Slafvdvln in A549 Cells

The ability of **Slafvdvln** to induce apoptosis was quantified using Annexin V-FITC and Propidium Iodide (PI) staining followed by flow cytometry analysis. A549 cells were treated with **Slafvdvln** for 48 hours.

Treatment	Concentration (nM)	Early Apoptosis (%)	Late Apoptosis/Necrosis (%)
Vehicle (DMSO)	-	3.2 ± 0.8	1.5 ± 0.4
Slafvdvln	50	15.7 ± 2.1	4.3 ± 1.2
Slafvdvln	100	35.2 ± 3.5	10.8 ± 2.3
Slafvdvln	200	58.9 ± 4.2	18.6 ± 2.9

Signaling Pathway

The PI3K/Akt/mTOR pathway is a key signaling cascade that promotes cell survival and proliferation. **Slafvdvln** inhibits this pathway, leading to a decrease in the phosphorylation of downstream effectors, ultimately resulting in reduced cell proliferation and increased apoptosis.

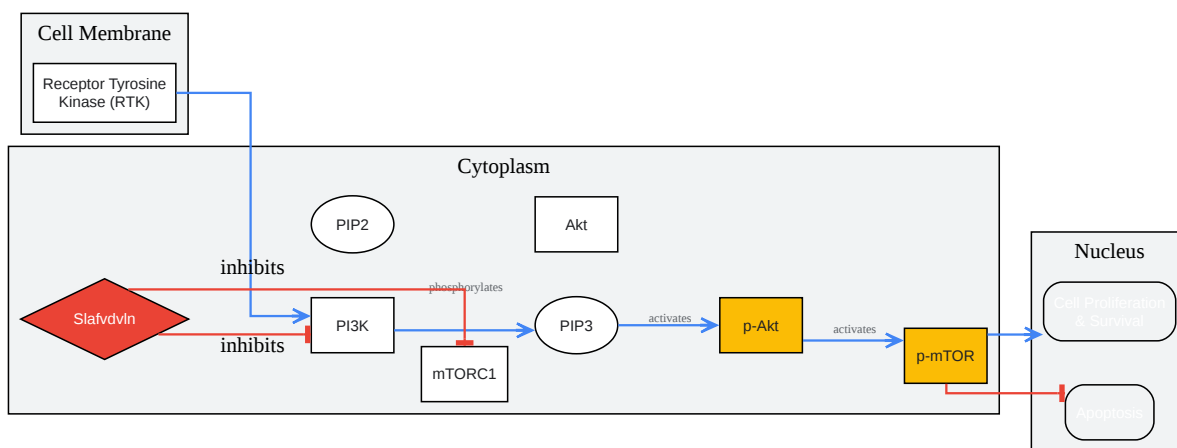

[Click to download full resolution via product page](#)

Caption: Slafvdvln inhibits the PI3K/Akt/mTOR signaling pathway.

Experimental Protocols

Cell Viability Assay (MTT Assay)

This protocol is for determining the cytotoxic effects of **Slafvdvln** on cancer cells in a 96-well format.^{[6][7]}

Materials:

- Cancer cell line of interest
- Complete cell culture medium
- **Slafvdvln** stock solution (10 mM in DMSO)
- 96-well flat-bottom plates

- MTT (3-(4,5-dimethylthiazol-2-yl)-2,5-diphenyltetrazolium bromide) solution (5 mg/mL in PBS)
- DMSO
- Microplate reader

Procedure:

- Seed cells in a 96-well plate at a density of 5,000-10,000 cells/well in 100 μ L of complete medium.[8]
- Incubate the plate for 24 hours at 37°C in a 5% CO₂ incubator.
- Prepare serial dilutions of **Slafvdvln** in complete medium. The final concentrations should range from 0.1 nM to 10 μ M. Also, prepare a vehicle control (DMSO) with the same final DMSO concentration as the highest **Slafvdvln** concentration.
- Remove the medium from the wells and add 100 μ L of the **Slafvdvln** dilutions or vehicle control.
- Incubate the plate for 72 hours at 37°C in a 5% CO₂ incubator.
- Add 10 μ L of MTT solution to each well and incubate for 4 hours at 37°C.[8]
- Carefully remove the medium and add 100 μ L of DMSO to each well to dissolve the formazan crystals.[8]
- Shake the plate for 15 minutes on an orbital shaker to ensure complete dissolution.
- Measure the absorbance at 570 nm using a microplate reader.[8]

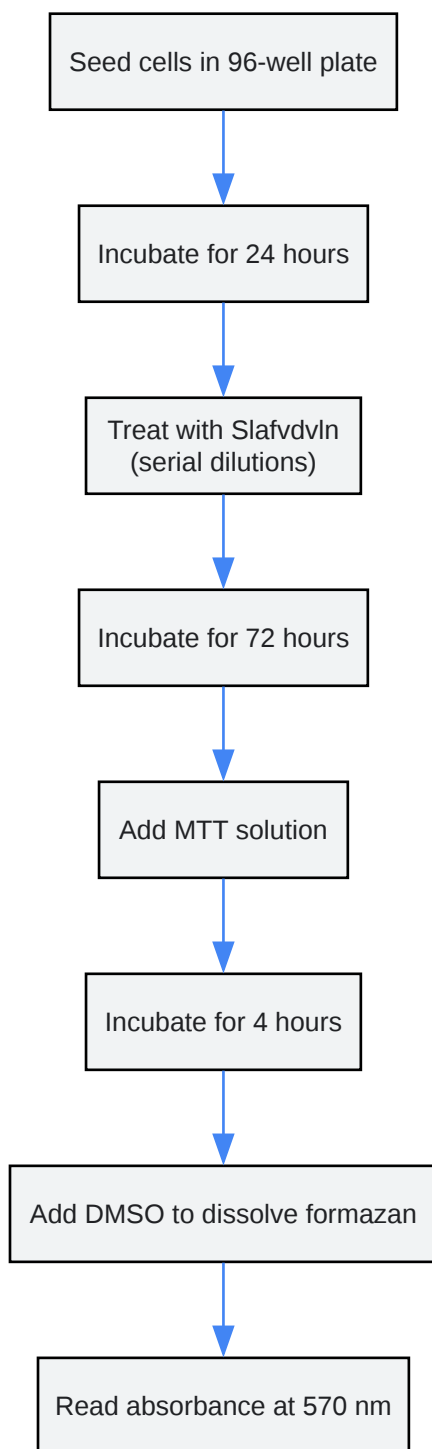

[Click to download full resolution via product page](#)

Caption: Workflow for the MTT cell viability assay.

Apoptosis Assay (Annexin V-FITC/PI Staining)

This protocol describes the detection of apoptosis induced by **SlafvdvIn** using flow cytometry.

[9]

Materials:

- Cancer cell line of interest
- 6-well plates
- **SlafvdvIn** stock solution (10 mM in DMSO)
- Annexin V-FITC Apoptosis Detection Kit (containing Annexin V-FITC, Propidium Iodide, and Binding Buffer)
- Phosphate-Buffered Saline (PBS)
- Flow cytometer

Procedure:

- Seed cells in 6-well plates and allow them to attach overnight.
- Treat the cells with various concentrations of **SlafvdvIn** and a vehicle control for 48 hours.
- Harvest the cells, including any floating cells, by trypsinization and centrifugation.
- Wash the cells twice with cold PBS.
- Resuspend the cells in 1X Binding Buffer at a concentration of 1×10^6 cells/mL.
- Transfer 100 μ L of the cell suspension to a new tube.
- Add 5 μ L of Annexin V-FITC and 5 μ L of Propidium Iodide to the cell suspension.
- Gently vortex the cells and incubate for 15 minutes at room temperature in the dark.[10]
- Add 400 μ L of 1X Binding Buffer to each tube.
- Analyze the cells by flow cytometry within one hour.

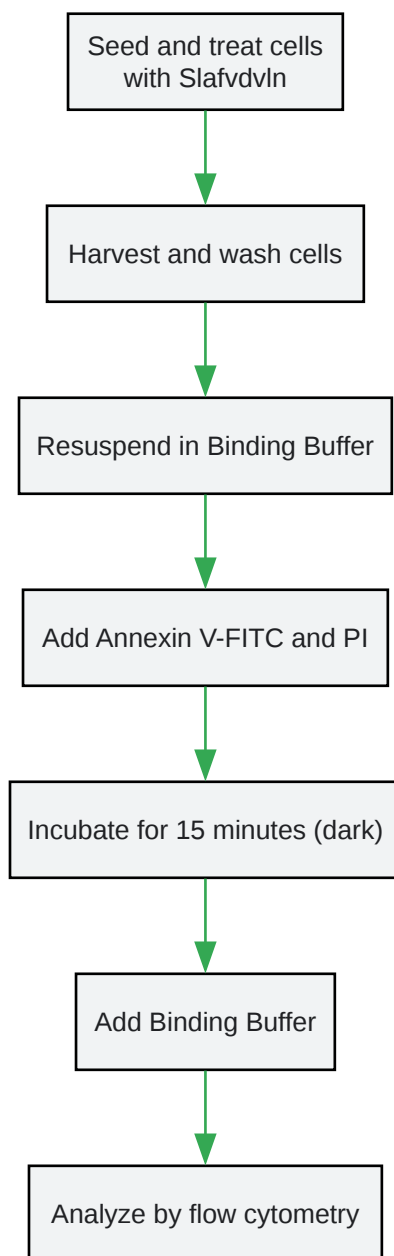

[Click to download full resolution via product page](#)

Caption: Workflow for the Annexin V/PI apoptosis assay.

Western Blotting

This protocol is for analyzing the effect of **Slafvdvln** on the phosphorylation status of key proteins in the PI3K/Akt/mTOR pathway.[11][12]

Materials:

- Cancer cell line of interest
- 6-well plates
- **SlafvdvIn** stock solution (10 mM in DMSO)
- RIPA lysis buffer with protease and phosphatase inhibitors
- BCA Protein Assay Kit
- SDS-PAGE gels
- PVDF membrane
- Blocking buffer (5% non-fat milk or BSA in TBST)
- Primary antibodies (e.g., anti-p-Akt, anti-Akt, anti-p-mTOR, anti-mTOR, anti- β -actin)
- HRP-conjugated secondary antibodies
- Chemiluminescent substrate
- Imaging system

Procedure:

- Seed cells in 6-well plates and treat with **SlafvdvIn** for the desired time (e.g., 24 hours).
- Wash the cells with cold PBS and lyse them with RIPA buffer.[\[11\]](#)
- Scrape the cells and collect the lysate. Centrifuge to pellet cell debris.[\[11\]](#)
- Determine the protein concentration of the supernatant using a BCA assay.
- Prepare samples for loading by adding Laemmli sample buffer and boiling for 5 minutes.[\[11\]](#)
- Load equal amounts of protein (20-30 μ g) onto an SDS-PAGE gel and perform electrophoresis.[\[12\]](#)

- Transfer the separated proteins to a PVDF membrane.[13]
- Block the membrane with blocking buffer for 1 hour at room temperature.[14]
- Incubate the membrane with the primary antibody overnight at 4°C.[11]
- Wash the membrane with TBST and incubate with the HRP-conjugated secondary antibody for 1 hour at room temperature.[12]
- Wash the membrane again with TBST.
- Add the chemiluminescent substrate and visualize the protein bands using an imaging system.

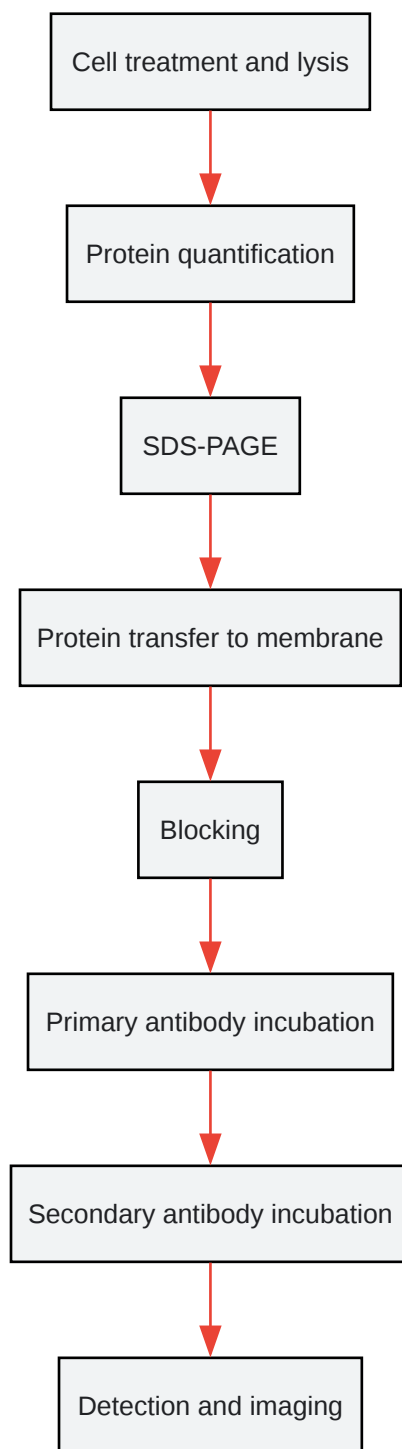

[Click to download full resolution via product page](#)

Need Custom Synthesis?

BenchChem offers custom synthesis for rare earth carbides and specific isotopic labeling.

Email: info@benchchem.com or [Request Quote Online](#).

References

- 1. PI3K/AKT/mTOR pathway - Wikipedia [en.wikipedia.org]
- 2. aacrjournals.org [aacrjournals.org]
- 3. assets.fishersci.com [assets.fishersci.com]
- 4. pubs.acs.org [pubs.acs.org]
- 5. rsc.org [rsc.org]
- 6. broadpharm.com [broadpharm.com]
- 7. merckmillipore.com [merckmillipore.com]
- 8. CyQUANT MTT Cell Proliferation Assay Kit Protocol | Thermo Fisher Scientific - AU [thermofisher.com]
- 9. ucl.ac.uk [ucl.ac.uk]
- 10. BestProtocols: Annexin V Staining Protocol for Flow Cytometry | Thermo Fisher Scientific - JP [thermofisher.com]
- 11. Western Blot Procedure | Cell Signaling Technology [cellsignal.com]
- 12. Western Blot Protocol - Creative Biolabs [modelorg-ab.creative-biolabs.com]
- 13. bosterbio.com [bosterbio.com]
- 14. Western Blot Protocol | Proteintech Group [ptglab.com]
- To cite this document: BenchChem. [SlafvdlIn Application Notes and Protocols for Cell Culture Experiments]. BenchChem, [2025]. [Online PDF]. Available at: [https://www.benchchem.com/product/b15616946#slafvdlIn-dosage-for-cell-culture-experiments]

Disclaimer & Data Validity:

The information provided in this document is for Research Use Only (RUO) and is strictly not intended for diagnostic or therapeutic procedures. While BenchChem strives to provide accurate protocols, we make no warranties, express or implied, regarding the fitness of this product for every specific experimental setup.

Technical Support: The protocols provided are for reference purposes. Unsure if this reagent suits your experiment? [[Contact our Ph.D. Support Team for a compatibility check](#)]

Need Industrial/Bulk Grade? [Request Custom Synthesis Quote](#)

BenchChem

Our mission is to be the trusted global source of essential and advanced chemicals, empowering scientists and researchers to drive progress in science and industry.

Contact

Address: 3281 E Guasti Rd
Ontario, CA 91761, United States
Phone: (601) 213-4426
Email: info@benchchem.com