

# SD-70 delivery to the central nervous system

**Author:** BenchChem Technical Support Team. **Date:** December 2025

## Compound of Interest

Compound Name: SD-70

Cat. No.: B15583486

[Get Quote](#)

## Disclaimer

The following document is a hypothetical Application Note and Protocol created for a compound designated "SD-70." As of the date of this document's generation, "SD-70" does not correspond to a publicly known therapeutic agent for central nervous system (CNS) delivery. The data, mechanisms, and protocols presented are illustrative and based on established methodologies in the field of CNS drug development. This document is intended to serve as a template and guide for researchers and professionals in the field.

## Application Notes and Protocols: SD-70 Delivery to the Central Nervous System

**Audience: Researchers, scientists, and drug development professionals.**

## Introduction

The blood-brain barrier (BBB) represents a significant obstacle in the development of therapeutics for central nervous system (CNS) disorders, as it restricts the passage of most molecules from the bloodstream into the brain.<sup>[1][2][3]</sup> This barrier is formed by the tight junctions of capillary endothelial cells and is crucial for protecting the CNS from toxins and pathogens.<sup>[2][4]</sup> However, it also prevents the entry of potentially effective therapeutic agents. Overcoming this barrier is a key focus in the treatment of neurodegenerative diseases such as Alzheimer's, Parkinson's, and Huntington's disease.<sup>[5][6]</sup>

**SD-70** is a novel, small-molecule therapeutic candidate designed to penetrate the CNS and modulate pathways implicated in neurodegeneration. These application notes provide an overview of **SD-70**'s proposed mechanism of action, summarize key preclinical data regarding its CNS delivery, and offer detailed protocols for its evaluation in a research setting.

## Proposed Mechanism of Action of SD-70

**SD-70** is engineered to cross the blood-brain barrier via a dual mechanism: passive diffusion, owing to its optimized lipophilicity and molecular size, and active transport through interaction with a specific carrier-mediated transporter. Once in the CNS, **SD-70** is hypothesized to inhibit the activity of Glycogen Synthase Kinase 3 Beta (GSK-3 $\beta$ ), a key enzyme implicated in tau hyperphosphorylation and neuroinflammation, common pathological hallmarks of several neurodegenerative diseases. By inhibiting GSK-3 $\beta$ , **SD-70** aims to reduce neuronal damage and preserve cognitive function.

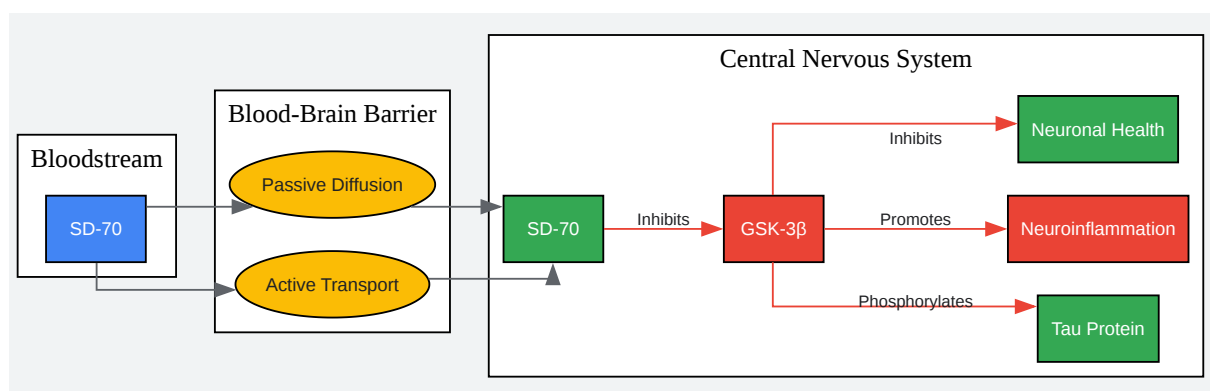

[Click to download full resolution via product page](#)

Caption: Proposed mechanism of **SD-70** crossing the BBB and acting on GSK-3 $\beta$ .

## Data Presentation: Preclinical Evaluation of SD-70

The following tables summarize the key quantitative data from preclinical studies of **SD-70**.

### Table 1: In Vitro Blood-Brain Barrier Permeability

This table presents data from an in vitro BBB model using human brain-like endothelial cells (hBLECs) to assess the permeability of **SD-70**.

Compound	Papp (A → B) (x 10 <sup>-6</sup> cm/s)	Efflux Ratio (B → A / A → B)
SD-70	15.2 ± 1.8	1.1 ± 0.2
Caffeine (High Permeability Control)	25.5 ± 2.1	1.0 ± 0.1
Atenolol (Low Permeability Control)	0.8 ± 0.3	1.2 ± 0.3

Data are presented as mean ± SD, n=3.

## Table 2: In Vivo Pharmacokinetics in Rodent Model (Single IV Dose)

This table summarizes the pharmacokinetic parameters of **SD-70** in rats following a single intravenous injection. Brain and plasma samples were collected at various time points.

Parameter	Value
Dose (IV)	5 mg/kg
Plasma Half-life (t <sub>1/2</sub> )	3.5 hours
Plasma AUC (0-t)	12,500 ng·h/mL
Brain C <sub>max</sub>	850 ng/g
Brain AUC (0-t)	4,800 ng·h/g
Brain-to-Plasma Ratio (AUC <sub>brain</sub> /AUC <sub>plasma</sub> )	0.38
Unbound Brain-to-Plasma Ratio (K <sub>p,uu,brain</sub> )	0.35

Data are presented as mean, n=5 animals per time point.

## Table 3: Target Engagement in Mouse Brain

This table shows the effect of **SD-70** on the phosphorylation of a downstream target of GSK-3 $\beta$  in the mouse brain, as measured by ELISA.

Treatment Group	Dose (mg/kg)	p-Tau (Ser396) Reduction (%)
Vehicle Control	-	0%
SD-70	10	45% $\pm$ 5.2%
SD-70	30	72% $\pm$ 8.1%

Data are presented as mean  $\pm$  SD, n=6 animals per group.

## Experimental Protocols

Detailed methodologies for the key experiments are provided below.

### Protocol 1: In Vitro BBB Permeability Assay

Objective: To determine the bidirectional permeability of **SD-70** across a cellular model of the blood-brain barrier.

Materials:

- Human brain-like endothelial cells (hBLECs)
- Transwell inserts (0.4  $\mu$ m pore size)
- Assay buffer (HBSS with 10 mM HEPES, pH 7.4)
- **SD-70**, Caffeine, Atenolol
- LC-MS/MS system for quantification

Method:

- Cell Culture: Culture hBLECs on Transwell inserts until a confluent monolayer is formed, confirmed by Transendothelial Electrical Resistance (TEER) measurement  $>$  200  $\Omega$ ·cm<sup>2</sup>.

- Apical to Basolateral (A → B) Permeability: a. Wash the cell monolayer twice with pre-warmed assay buffer. b. Add assay buffer containing the test compound (10 μM **SD-70**) to the apical (upper) chamber. c. Add fresh assay buffer to the basolateral (lower) chamber. d. Incubate at 37°C with 5% CO<sub>2</sub> on an orbital shaker. e. Collect samples from the basolateral chamber at 15, 30, 60, and 120 minutes. Replace with an equal volume of fresh buffer. f. Collect a final sample from the apical chamber at 120 minutes.
- Basolateral to Apical (B → A) Permeability: a. Repeat the process, but add the test compound to the basolateral chamber and sample from the apical chamber.
- Quantification: Analyze the concentration of the compound in all samples using a validated LC-MS/MS method.
- Calculation: Calculate the apparent permeability coefficient (P<sub>app</sub>) using the formula:  $P_{app} = (dQ/dt) / (A * C_0)$ , where dQ/dt is the rate of compound appearance in the receiver chamber, A is the surface area of the membrane, and C<sub>0</sub> is the initial concentration in the donor chamber. Calculate the efflux ratio by dividing P<sub>app</sub> (B → A) by P<sub>app</sub> (A → B).

## Protocol 2: In Vivo Pharmacokinetic Study in Rats

Objective: To assess the brain and plasma concentration-time profile of **SD-70** after intravenous administration.

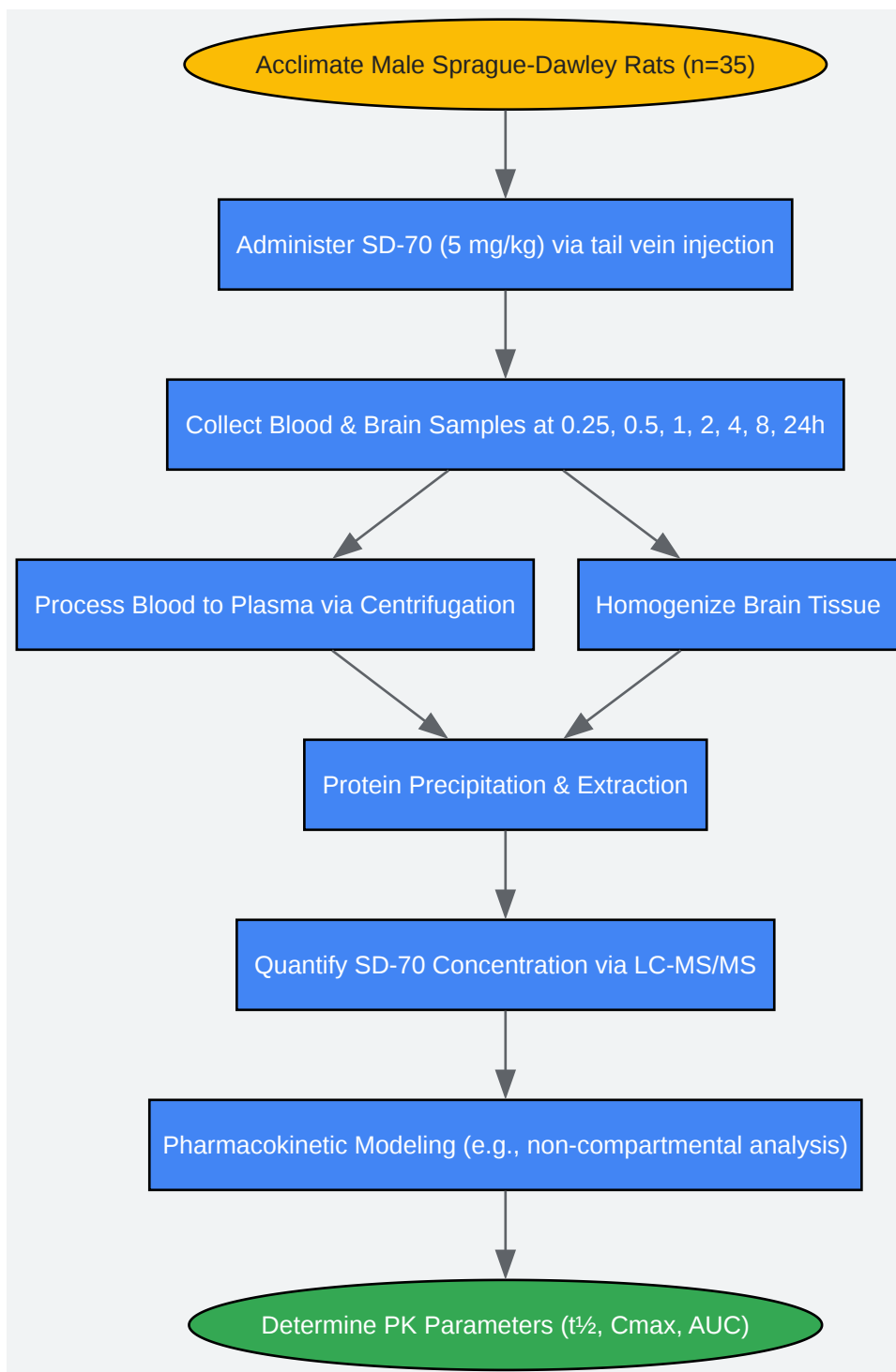

[Click to download full resolution via product page](#)

Caption: Workflow for the in vivo pharmacokinetic study of **SD-70**.

Materials:

- Male Sprague-Dawley rats (250-300g)
- **SD-70** formulated in 5% DMSO, 40% PEG300, 55% Saline
- Anesthesia (e.g., isoflurane)
- LC-MS/MS system

#### Method:

- Acclimation: Acclimate animals for at least 7 days prior to the study.
- Dosing: Administer a single 5 mg/kg dose of **SD-70** via the tail vein.
- Sample Collection: a. At designated time points (e.g., 0.25, 0.5, 1, 2, 4, 8, and 24 hours post-dose), anesthetize a cohort of animals (n=5 per time point). b. Collect blood via cardiac puncture into EDTA-containing tubes. c. Immediately perfuse the brain with ice-cold saline to remove remaining blood. d. Excise the whole brain, weigh it, and flash-freeze in liquid nitrogen.
- Sample Processing: a. Centrifuge blood samples at 2,000 x g for 15 minutes at 4°C to separate plasma. b. Homogenize brain tissue in a suitable buffer.
- Quantification: a. Perform protein precipitation on plasma and brain homogenate samples. b. Analyze the supernatant for **SD-70** concentration using a validated LC-MS/MS method.
- Data Analysis: Calculate pharmacokinetic parameters (C<sub>max</sub>, t<sub>1/2</sub>, AUC) for both plasma and brain compartments using appropriate software (e.g., Phoenix WinNonlin).

## Conclusion

The presented data indicate that **SD-70** is a promising CNS drug candidate with good in vitro BBB permeability and significant brain penetration in vivo. The observed target engagement in the brain further supports its potential as a therapeutic for neurodegenerative diseases. The protocols outlined here provide a robust framework for researchers to replicate and expand upon these findings. Further studies should focus on oral bioavailability, chronic dosing regimens, and efficacy in disease models.

**Need Custom Synthesis?**

BenchChem offers custom synthesis for rare earth carbides and specific isotopic labeling.

Email: [info@benchchem.com](mailto:info@benchchem.com) or [Request Quote Online](#).

## References

- 1. tandfonline.com [tandfonline.com]
- 2. woongbee.com [woongbee.com]
- 3. Strategies for Enhanced Drug Delivery to the Central Nervous System - PMC [pmc.ncbi.nlm.nih.gov]
- 4. Blood-Brain Barrier Disruption Increases Amyloid-Related Pathology in TgSwDI Mice - PMC [pmc.ncbi.nlm.nih.gov]
- 5. Closest horizons of Hsp70 engagement to manage neurodegeneration - PMC [pmc.ncbi.nlm.nih.gov]
- 6. Old Drugs as New Treatments for Neurodegenerative Diseases - PMC [pmc.ncbi.nlm.nih.gov]
- To cite this document: BenchChem. [SD-70 delivery to the central nervous system]. BenchChem, [2025]. [Online PDF]. Available at: [https://www.benchchem.com/product/b15583486#sd-70-delivery-to-the-central-nervous-system]

---

**Disclaimer & Data Validity:**

The information provided in this document is for Research Use Only (RUO) and is strictly not intended for diagnostic or therapeutic procedures. While BenchChem strives to provide accurate protocols, we make no warranties, express or implied, regarding the fitness of this product for every specific experimental setup.

**Technical Support:** The protocols provided are for reference purposes. Unsure if this reagent suits your experiment? [[Contact our Ph.D. Support Team for a compatibility check](#)]

**Need Industrial/Bulk Grade?** [Request Custom Synthesis Quote](#)



# BenchChem

Our mission is to be the trusted global source of essential and advanced chemicals, empowering scientists and researchers to drive progress in science and industry.

## Contact

Address: 3281 E Guasti Rd

Ontario, CA 91761, United States

Phone: (601) 213-4426

Email: [info@benchchem.com](mailto:info@benchchem.com)