

Reversing Histone H3 Hyperacetylation: A Comparative Guide to the Efficacy of iP300w

Author: BenchChem Technical Support Team. **Date:** December 2025

Compound of Interest

Compound Name: iP300w

Cat. No.: B3028336

[Get Quote](#)

For researchers, scientists, and drug development professionals, this guide provides a comprehensive comparison of **iP300w**'s ability to reverse histone H3 hyperacetylation, with supporting experimental data and methodologies. We objectively assess its performance against other alternatives, offering a clear perspective for your research and development endeavors.

Histone acetylation is a critical epigenetic modification pivotal in regulating gene expression. The balance between histone acetyltransferases (HATs) and histone deacetylases (HDACs) dictates the acetylation status of histones, thereby influencing chromatin structure and accessibility for transcription.[1][2][3] Hyperacetylation of histone H3, often associated with transcriptional activation, can be dysregulated in various diseases. This guide focuses on validating the reversal of this epigenetic mark by **iP300w**, a potent and selective inhibitor of the p300/CBP histone acetyltransferases.[4][5]

Performance Comparison of p300/CBP Inhibitors

iP300w has demonstrated significant efficacy in reversing histone H3 hyperacetylation, particularly in models of facioscapulohumeral muscular dystrophy (FSHD) where the aberrant expression of the DUX4 transcription factor drives p300/CBP-mediated hyperacetylation. The following table summarizes the performance of **iP300w** in comparison to other known p300/CBP inhibitors, A-485 and C646.

Inhibitor	Target(s)	Potency (IC50)	Observed Effect on Histone H3 Acetylation	Key Findings & Limitations
iP300w	p300/CBP	p300: 19 nM, 33 nM	Effectively reverses DUX4-induced global hyperacetylation of H3K27ac and H3K18ac. Also reduces basal levels of H3 acetylation.	A spirocyclic EP300/CBP inhibitor that demonstrates potent activity in cellular and in vivo models of FSHD. It blocks DUX4-mediated transcription and cytotoxicity. Quantitative densitometry data from primary studies is not available.
A-485	p300/CBP	p300: 9.8 nM; CBP: 2.6 nM	Reduces global levels of H3K27ac and H3K18ac.	A potent and selective p300/CBP inhibitor. While it effectively reduces histone acetylation, direct comparative studies with iP300w in the context of DUX4-induced hyperacetylation are limited.

C646	p300/CBP	p300: 400 nM (Ki)	Reduces levels of H3K9ac, H3K18ac, and H3K27ac in various cell lines.	A widely used p300/CBP inhibitor, but it is less potent than iP300w and A-485. Some studies suggest it may have off-target effects.
------	----------	-------------------	---	---

Signaling Pathway and Experimental Workflow

To understand the mechanism of action of **iP300w**, it is crucial to visualize the signaling pathway leading to histone H3 hyperacetylation and the experimental workflow used to validate its reversal.

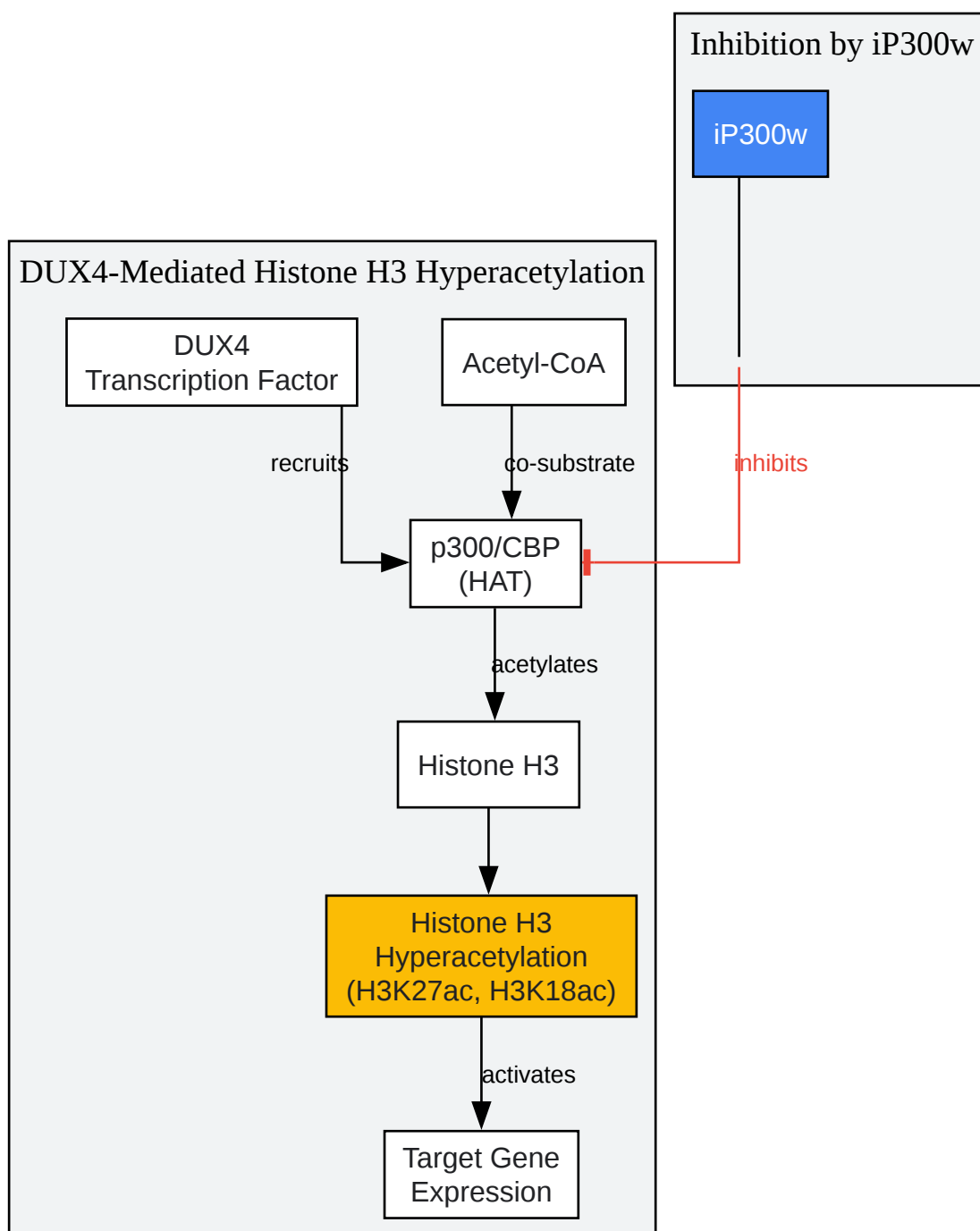

[Click to download full resolution via product page](#)

Caption: DUX4-p300/CBP signaling pathway and the inhibitory action of **iP300w**.

The experimental validation of **iP300w**'s activity typically follows a workflow involving cell culture, induction of histone hyperacetylation, treatment with the inhibitor, and subsequent analysis of histone modifications.

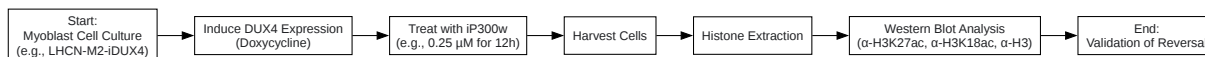

[Click to download full resolution via product page](#)

Caption: Experimental workflow for validating the reversal of histone H3 hyperacetylation.

Experimental Protocols

Detailed methodologies are essential for reproducing and building upon these findings. The following are key experimental protocols used in the validation of **iP300w**.

Cell Culture and DUX4 Induction

- Cell Line: LHCN-M2 human myoblasts with a doxycycline-inducible DUX4 transgene (LHCN-M2-iDUX4) are commonly used.
- Culture Medium: Cells are maintained in a suitable growth medium, such as a 3:1 mixture of DMEM and Medium 199, supplemented with 15% fetal bovine serum (FBS), and a cocktail of growth factors including dexamethasone, human insulin, human basic fibroblast growth factor (bFGF), and human epidermal growth factor (EGF).
- Induction of DUX4 Expression: To induce histone H3 hyperacetylation, DUX4 expression is triggered by adding doxycycline to the culture medium at a concentration of 20-200 ng/mL for 12-24 hours.

iP300w Treatment

- Stock Solution: A stock solution of **iP300w** is prepared in dimethyl sulfoxide (DMSO).
- Treatment: Following DUX4 induction, cells are treated with **iP300w** at a final concentration typically ranging from 0.1 μM to 1 μM for a specified duration, such as 12 hours. A vehicle control (DMSO) is run in parallel.

Western Blot for Histone H3 Acetylation

- Histone Extraction: Histones are extracted from harvested cells using an acid extraction method.
 - Wash the cell pellet with ice-cold PBS containing 5 mM sodium butyrate (an HDAC inhibitor).
 - Lyse the cells in a Triton extraction buffer.
 - Isolate the nuclei by centrifugation.
 - Resuspend the nuclear pellet in 0.2 N HCl and extract histones overnight at 4°C.
 - Clarify the extract by centrifugation and neutralize the supernatant.
- Protein Quantification: The protein concentration of the histone extracts is determined using a Bradford assay.
- SDS-PAGE and Transfer:
 - Equal amounts of histone extracts (typically 10-20 µg) are resolved on a 15% SDS-polyacrylamide gel.
 - Proteins are then transferred to a polyvinylidene difluoride (PVDF) membrane.
- Immunoblotting:
 - The membrane is blocked with 5% non-fat milk or bovine serum albumin (BSA) in Tris-buffered saline with 0.1% Tween 20 (TBST) for 1 hour at room temperature.
 - The membrane is incubated overnight at 4°C with primary antibodies specific for acetylated histone H3 at lysine 27 (α -H3K27ac) and lysine 18 (α -H3K18ac). An antibody against total histone H3 (α -H3) is used as a loading control.
 - After washing with TBST, the membrane is incubated with a horseradish peroxidase (HRP)-conjugated secondary antibody for 1 hour at room temperature.
- Detection: The protein bands are visualized using an enhanced chemiluminescence (ECL) detection reagent.

- Quantitative Analysis: The band intensities are quantified using densitometry software. The levels of acetylated H3 are normalized to the total H3 levels.

Conclusion

The available evidence strongly supports the efficacy of **iP300w** in reversing histone H3 hyperacetylation, particularly in the context of DUX4-driven pathology. Its high potency and specificity for p300/CBP make it a valuable tool for research into epigenetic regulation and a promising candidate for therapeutic development. While direct quantitative comparisons with other inhibitors in the same model system are limited, the existing data positions **iP300w** as a superior agent for inhibiting p300/CBP-mediated histone hyperacetylation. The detailed protocols provided in this guide should enable researchers to further validate and expand upon these important findings.

Need Custom Synthesis?

BenchChem offers custom synthesis for rare earth carbides and specific isotopic labeling.

Email: info@benchchem.com or [Request Quote Online](#).

References

1. Methods for the analysis of histone H3 and H4 acetylation in blood - PMC [pmc.ncbi.nlm.nih.gov]
 2. researchgate.net [researchgate.net]
 3. researchgate.net [researchgate.net]
 4. Histone acetyltransferase inhibitor C646 reverses epithelial to mesenchymal transition of human peritoneal mesothelial cells via blocking TGF- β 1/Smad3 signaling pathway in vitro - PMC [pmc.ncbi.nlm.nih.gov]
 5. A novel P300 inhibitor reverses DUX4-mediated global histone H3 hyperacetylation, target gene expression, and cell death - PubMed [pubmed.ncbi.nlm.nih.gov]
- To cite this document: BenchChem. [Reversing Histone H3 Hyperacetylation: A Comparative Guide to the Efficacy of iP300w]. BenchChem, [2025]. [Online PDF]. Available at: [https://www.benchchem.com/product/b3028336#validating-the-reversal-of-histone-h3-hyperacetylation-by-ip300w]

Disclaimer & Data Validity:

The information provided in this document is for Research Use Only (RUO) and is strictly not intended for diagnostic or therapeutic procedures. While BenchChem strives to provide accurate protocols, we make no warranties, express or implied, regarding the fitness of this product for every specific experimental setup.

Technical Support: The protocols provided are for reference purposes. Unsure if this reagent suits your experiment? [[Contact our Ph.D. Support Team for a compatibility check](#)]

Need Industrial/Bulk Grade? [Request Custom Synthesis Quote](#)

BenchChem

Our mission is to be the trusted global source of essential and advanced chemicals, empowering scientists and researchers to drive progress in science and industry.

Contact

Address: 3281 E Guasti Rd
Ontario, CA 91761, United States
Phone: (601) 213-4426
Email: info@benchchem.com