

Research Protocol: Investigating the Bioactivities of Rhodiocyanoside A

Author: BenchChem Technical Support Team. **Date:** December 2025

Compound of Interest

Compound Name: Rhodiocyanoside A

Cat. No.: B1234724

[Get Quote](#)

Application Notes

This document provides a comprehensive set of protocols for researchers, scientists, and drug development professionals to investigate the biological activities of **Rhodiocyanoside A**, a cyanoglycoside isolated from *Rhodiola* species. The primary reported activity of **Rhodiocyanoside A** is its antiallergic potential, specifically the inhibition of histamine release. [1] This protocol outlines methods to verify this activity, explore the underlying mechanisms, and investigate other potential therapeutic properties such as antioxidant and anti-inflammatory effects, which are common to compounds from the *Rhodiola* genus.

The provided protocols are intended as a guide and may require optimization based on specific laboratory conditions and research objectives.

Quantitative Data Summary

There is a lack of publicly available quantitative data on the specific bioactivities of **Rhodiocyanoside A**. The following tables are provided as templates for researchers to populate with experimentally derived data.

Table 1: In Vitro Antiallergic Activity of **Rhodiocyanoside A**

Assay	Cell Type	Stimulant	IC50 (µM)	Positive Control
Histamine Release	Rat Peritoneal Mast Cells	Compound 48/80	Data to be determined	Quercetin
Histamine Release	RBL-2H3 cells	IgE/Antigen	Data to be determined	Ketotifen
β-hexosaminidase Release	RBL-2H3 cells	IgE/Antigen	Data to be determined	Cromolyn sodium

 Table 2: In Vivo Antiallergic Activity of **Rhodiocyanoside A**

Assay	Animal Model	End-point Measurement	% Inhibition (at dose)	Positive Control
Passive Cutaneous Anaphylaxis (PCA)	Rat	Evans blue dye extravasation	Data to be determined	Cyproheptadine
Passive Cutaneous Anaphylaxis (PCA)	Mouse	Ear swelling	Data to be determined	Cetirizine

 Table 3: In Vitro Antioxidant and Anti-inflammatory Activity of **Rhodiocyanoside A**

Assay	Method	IC50 (μM)	Positive Control
Antioxidant	DPPH radical scavenging	Data to be determined	Ascorbic Acid
Antioxidant	ABTS radical scavenging	Data to be determined	Trolox
Anti-inflammatory	Nitric Oxide (NO) inhibition in LPS-stimulated RAW 264.7 cells	Data to be determined	Dexamethasone
Anti-inflammatory	TNF- α inhibition in LPS-stimulated RAW 264.7 cells	Data to be determined	Dexamethasone
Anti-inflammatory	IL-6 inhibition in LPS-stimulated RAW 264.7 cells	Data to be determined	Dexamethasone

Experimental Protocols

In Vitro Antiallergic Activity

2.1.1 Histamine Release Assay from Rat Peritoneal Mast Cells

This protocol is adapted from methods describing the isolation and stimulation of rat peritoneal mast cells.[\[2\]](#)[\[3\]](#)[\[4\]](#)[\[5\]](#)

Materials:

- Male Wistar rats (200-250 g)
- Hanks' Balanced Salt Solution (HBSS)
- Bovine Serum Albumin (BSA)
- Collagenase

- Compound 48/80 (stimulant)
- **Rhodiocyanoside A**
- Quercetin (positive control)
- o-phthalaldehyde (OPT) for fluorometric detection of histamine

Procedure:

- Euthanize a rat and inject 20 mL of ice-cold HBSS containing 0.1% BSA into the peritoneal cavity.
- Gently massage the abdomen for 2-3 minutes.
- Aspirate the peritoneal fluid and centrifuge at 150 x g for 10 minutes at 4°C.
- Wash the cell pellet twice with cold HBSS.
- Resuspend the cells in HBSS and purify mast cells using a Percoll gradient.
- Resuspend the purified mast cells in HBSS with 0.1% BSA.
- Pre-incubate the mast cells with various concentrations of **Rhodiocyanoside A** or quercetin for 15 minutes at 37°C.
- Add Compound 48/80 (final concentration 10 µg/mL) to induce histamine release and incubate for 20 minutes at 37°C.
- Stop the reaction by placing the tubes on ice and centrifuge at 150 x g for 10 minutes at 4°C.
- Collect the supernatant and measure the histamine content using the OPT fluorometric method.
- To determine the total histamine content, lyse an aliquot of cells with Triton X-100.
- Calculate the percentage of histamine release and the inhibition by **Rhodiocyanoside A**.

2.1.2 Western Blot Analysis of Signaling Proteins in Mast Cells

This protocol aims to investigate the effect of **Rhodiocyanoside A** on key signaling proteins involved in mast cell degranulation.

Materials:

- RBL-2H3 cells
- Anti-DNP IgE
- DNP-HSA (antigen)
- **Rhodiocyanoside A**
- Lysis buffer (RIPA)
- Proteinase and phosphatase inhibitors
- Antibodies against phospho-Syk, phospho-PLC γ , phospho-ERK, phospho-p38, and their total forms.

Procedure:

- Sensitize RBL-2H3 cells with anti-DNP IgE overnight.
- Wash the cells and pre-treat with various concentrations of **Rhodiocyanoside A** for 1 hour.
- Stimulate the cells with DNP-HSA for 10-15 minutes.
- Wash the cells with ice-cold PBS and lyse with RIPA buffer containing inhibitors.
- Determine the protein concentration of the lysates using a BCA assay.
- Separate the proteins by SDS-PAGE and transfer to a PVDF membrane.
- Block the membrane and probe with primary antibodies overnight at 4°C.
- Wash and incubate with HRP-conjugated secondary antibodies.
- Visualize the protein bands using an enhanced chemiluminescence (ECL) detection system.

- Quantify the band intensities and normalize the phosphorylated protein levels to the total protein levels.

In Vivo Antiallergic Activity

2.2.1 Passive Cutaneous Anaphylaxis (PCA) in Rats

This protocol is based on established models of PCA.[\[6\]](#)[\[7\]](#)[\[8\]](#)

Materials:

- Male Wistar rats (200-250 g)
- Anti-DNP IgE
- DNP-HSA (antigen)
- Evans blue dye
- **Rhodiocyanoside A**
- Cyproheptadine (positive control)
- Saline

Procedure:

- Passively sensitize rats by intradermal injection of 50 μ L of anti-DNP IgE into the dorsal skin.
- After 24 hours, administer **Rhodiocyanoside A** (various doses) or cyproheptadine orally.
- One hour after drug administration, challenge the rats by intravenous injection of 1 mL of saline containing 1 mg of DNP-HSA and 0.5% Evans blue dye.
- After 30 minutes, euthanize the rats and excise the blue-stained skin areas.
- Extract the Evans blue dye from the skin tissue using formamide.
- Measure the absorbance of the extracted dye at 620 nm.

- Calculate the percentage inhibition of the PCA reaction.

In Vitro Antioxidant Activity

2.3.1 DPPH Radical Scavenging Assay

This is a common and reliable method for assessing antioxidant activity.[9][10]

Materials:

- 2,2-diphenyl-1-picrylhydrazyl (DPPH)
- Methanol
- **Rhodiocyanoside A**
- Ascorbic acid (positive control)

Procedure:

- Prepare a 0.1 mM solution of DPPH in methanol.
- Add various concentrations of **Rhodiocyanoside A** or ascorbic acid to the DPPH solution in a 96-well plate.
- Incubate the plate in the dark at room temperature for 30 minutes.
- Measure the absorbance at 517 nm.
- Calculate the percentage of DPPH radical scavenging activity.

In Vitro Anti-inflammatory Activity

2.4.1 Nitric Oxide (NO) Inhibition Assay in RAW 264.7 Macrophages

This assay measures the ability of a compound to inhibit the production of the pro-inflammatory mediator nitric oxide.[11][12][13][14]

Materials:

- RAW 264.7 macrophage cell line
- Lipopolysaccharide (LPS)
- **Rhodiocyanoside A**
- Dexamethasone (positive control)
- Griess reagent

Procedure:

- Seed RAW 264.7 cells in a 96-well plate and allow them to adhere overnight.
- Pre-treat the cells with various concentrations of **Rhodiocyanoside A** or dexamethasone for 1 hour.
- Stimulate the cells with LPS (1 $\mu\text{g}/\text{mL}$) for 24 hours.
- Collect the cell culture supernatant.
- Determine the nitrite concentration in the supernatant using the Griess reagent, which correlates with NO production.
- Measure the absorbance at 540 nm.
- Perform a cell viability assay (e.g., MTT) to rule out cytotoxicity.
- Calculate the percentage of NO inhibition.

Signaling Pathways and Experimental Workflows

Proposed Signaling Pathway for Antiallergic Action of Rhodiocyanoside A

The following diagram illustrates the key signaling events in IgE-mediated mast cell degranulation and the potential points of intervention for **Rhodiocyanoside A**.

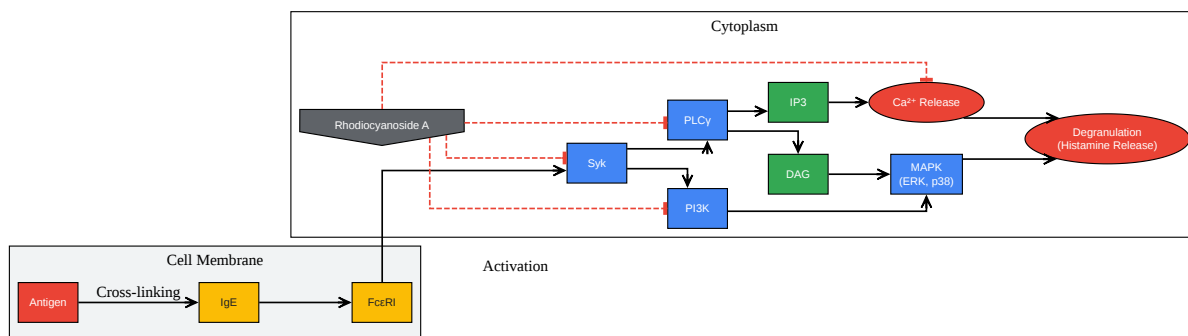

[Click to download full resolution via product page](#)

Caption: Proposed mechanism of **Rhodiocyanoside A** in mast cells.

Experimental Workflow for In Vitro Antiallergic Studies

This diagram outlines the workflow for assessing the antiallergic effects of **Rhodiocyanoside A** in vitro.

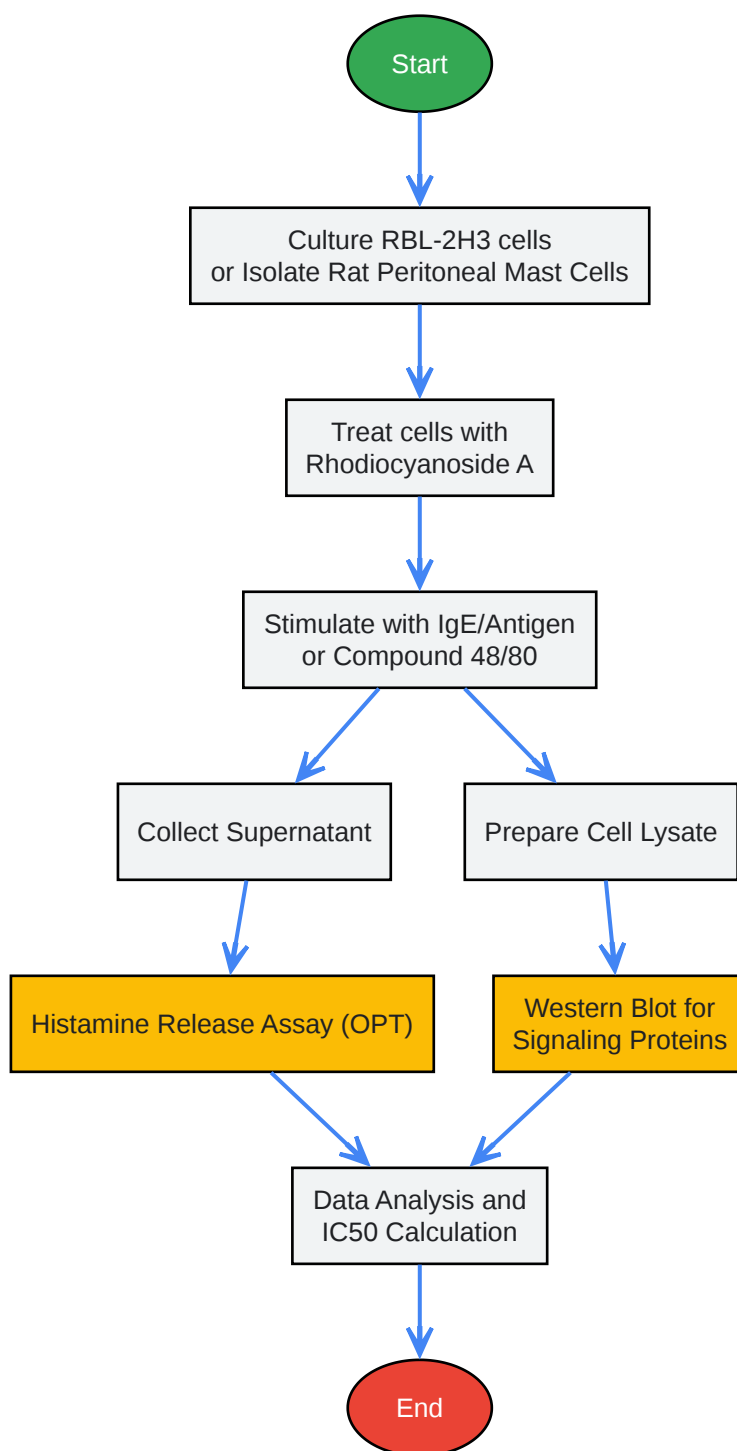

[Click to download full resolution via product page](#)

Caption: Workflow for in vitro antiallergic activity assessment.

Experimental Workflow for In Vivo PCA Studies

This diagram illustrates the steps involved in the in vivo passive cutaneous anaphylaxis model.

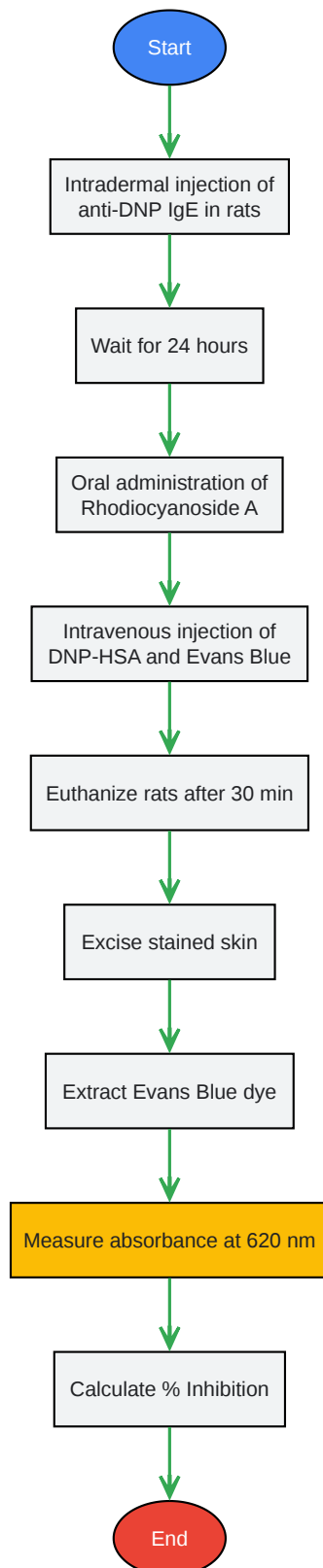

[Click to download full resolution via product page](#)

Caption: Workflow for in vivo passive cutaneous anaphylaxis study.

Need Custom Synthesis?

BenchChem offers custom synthesis for rare earth carbides and specific isotopic labeling.

Email: info@benchchem.com or [Request Quote Online](#).

References

- 1. Bioactive constituents of Chinese natural medicines. IV. Rhodiolae radix. (2).: On the histamine release inhibitors from the underground part of Rhodiola sacra (Prain ex Hamet) S. H. Fu (Crassulaceae): chemical structures of rhodiocyanoside D and sacranosides A and B - PubMed [pubmed.ncbi.nlm.nih.gov]
- 2. MAST CELL DEGRANULATION AND HISTAMINE RELEASE OBSERVED IN A NEW IN VITRO SYSTEM - PMC [pmc.ncbi.nlm.nih.gov]
- 3. Properties of hydrogen peroxide-induced histamine release from rat mast cells - PubMed [pubmed.ncbi.nlm.nih.gov]
- 4. Human eosinophils induce histamine release from antigen-activated rat peritoneal mast cells: a possible role for mast cells in late-phase allergic reactions - PubMed [pubmed.ncbi.nlm.nih.gov]
- 5. Rapid inhibitory effect of corticosterone on histamine release from rat peritoneal mast cells - PubMed [pubmed.ncbi.nlm.nih.gov]
- 6. criver.com [criver.com]
- 7. pharmacologydiscoveryservices.com [pharmacologydiscoveryservices.com]
- 8. Passive Cutaneous Anaphylaxis Model - Creative Bioarray | Creative Bioarray [creative-bioarray.com]
- 9. Antioxidant Activity in vitro [bio-protocol.org]
- 10. researchgate.net [researchgate.net]
- 11. Macrophage Inflammatory Assay [bio-protocol.org]
- 12. Macrophage Inflammatory Assay [en.bio-protocol.org]
- 13. Anti-inflammatory activity in macrophage cells | Nawah Scientific [nawah-scientific.com]
- 14. Macrophage Inflammatory Assay - PMC [pmc.ncbi.nlm.nih.gov]

- To cite this document: BenchChem. [Research Protocol: Investigating the Bioactivities of Rhodiocyanoside A]. BenchChem, [2025]. [Online PDF]. Available at: [https://www.benchchem.com/product/b1234724#developing-a-research-protocol-for-rhodiocyanoside-a-studies]

Disclaimer & Data Validity:

The information provided in this document is for Research Use Only (RUO) and is strictly not intended for diagnostic or therapeutic procedures. While BenchChem strives to provide accurate protocols, we make no warranties, express or implied, regarding the fitness of this product for every specific experimental setup.

Technical Support: The protocols provided are for reference purposes. Unsure if this reagent suits your experiment? [[Contact our Ph.D. Support Team for a compatibility check](#)]

Need Industrial/Bulk Grade? [Request Custom Synthesis Quote](#)

BenchChem

Our mission is to be the trusted global source of essential and advanced chemicals, empowering scientists and researchers to drive progress in science and industry.

Contact

Address: 3281 E Guasti Rd

Ontario, CA 91761, United States

Phone: (601) 213-4426

Email: info@benchchem.com