

# Replicating Key Studies on Flupentixol Dihydrochloride's PI3K Inhibition: A Comparative Guide

**Author:** BenchChem Technical Support Team. **Date:** December 2025

## Compound of Interest

Compound Name: *Flupentixol Dihydrochloride*

Cat. No.: *B023768*

[Get Quote](#)

For researchers, scientists, and drug development professionals, the replication of key scientific findings is a cornerstone of validation and further discovery. This guide provides a comprehensive comparison of **Flupentixol Dihydrochloride**'s performance as a Phosphoinositide 3-kinase (PI3K) inhibitor, with a focus on replicating pivotal study data. This document outlines the direct inhibitory effects of Flupentixol on PI3K $\alpha$  and compares its efficacy with other known PI3K inhibitors, supported by detailed experimental protocols and data visualizations.

## Comparative Analysis of PI3K Inhibitors

A key study identified Flupentixol, an antipsychotic agent, as a novel PI3K inhibitor with potential applications in cancer therapy.<sup>[1][2][3][4][5]</sup> The study demonstrated that Flupentixol directly inhibits PI3K $\alpha$  kinase activity and exhibits cytotoxic effects on lung cancer cell lines.<sup>[1][3][4]</sup> Its performance was compared with established PI3K inhibitors, BYL719 (Alpelisib), a PI3K $\alpha$ -selective inhibitor, and BKM120 (Buparlisib), a pan-PI3K inhibitor.<sup>[1][4]</sup>

## Quantitative Data Summary

The following table summarizes the half-maximal inhibitory concentration (IC<sub>50</sub>) values of **Flupentixol Dihydrochloride** in comparison to BYL719 and BKM120 in non-small cell lung cancer (NSCLC) cell lines, as reported in the foundational study.

Compound	Cell Line	IC50 ( $\mu\text{M}$ )	Duration
Flupentixol Dihydrochloride	A549	5.708	24 hours
H661	6.374	24 hours	
BYL719 (Alpelisib)	A549	45.9	24 hours
BKM120 (Buparlisib)	A549	63.9	24 hours

Data sourced from Dong et al. (2019).[1]

Additionally, the in vitro kinase assay revealed the direct inhibitory effect of Flupentixol on PI3K $\alpha$ .

Compound	Target	IC50 (nM)
Flupentixol Dihydrochloride	PI3K $\alpha$	127

Data sourced from publicly available databases.[6][7][8]

## Experimental Protocols

To facilitate the replication of these findings, detailed methodologies for the key experiments are provided below.

### Cell Viability Assay (MTT Assay)

This protocol is used to assess the cytotoxic effects of the inhibitors on cancer cell lines.[1][3][4][5]

Materials:

- NSCLC cell lines (e.g., A549, H661)
- RPMI 1640 medium with 10% fetal bovine serum (FBS)
- **Flupentixol Dihydrochloride**, BYL719, BKM120

- MTT (3-(4,5-dimethylthiazol-2-yl)-2,5-diphenyltetrazolium bromide) solution
- Dimethyl sulfoxide (DMSO)
- 96-well plates
- Microplate reader

#### Procedure:

- Seed A549 and H661 cells in 96-well plates at a density of  $5 \times 10^3$  cells per well and incubate for 24 hours.
- Treat the cells with increasing concentrations of **Flupentixol Dihydrochloride** (e.g., 2.5, 5, 10, 20, 40  $\mu\text{M}$ ), BYL719, or BKM120 for 24, 48, and 72 hours. Include a vehicle control (DMSO).
- After the treatment period, add 20  $\mu\text{L}$  of MTT solution (5 mg/mL) to each well and incubate for 4 hours at 37°C.
- Remove the medium and add 150  $\mu\text{L}$  of DMSO to each well to dissolve the formazan crystals.
- Measure the absorbance at 490 nm using a microplate reader.
- Calculate cell viability as a percentage of the vehicle-treated control. The IC<sub>50</sub> value is determined from the dose-response curve.

## In Vitro PI3K $\alpha$ Kinase Assay

This assay measures the direct inhibitory effect of a compound on the kinase activity of PI3K $\alpha$ . [3][5] A common method is the Homogeneous Time-Resolved Fluorescence (HTRF) assay.[9]

#### Materials:

- Recombinant human PI3K $\alpha$  enzyme
- PIP2 (phosphatidylinositol-4,5-bisphosphate) substrate

- ATP
- Assay buffer
- **Flupentixol Dihydrochloride**
- HTRF detection reagents (e.g., europium-labeled anti-phospho-PIP3 antibody and a fluorescent acceptor)
- 384-well plates
- HTRF-compatible plate reader

#### Procedure:

- Prepare serial dilutions of **Flupentixol Dihydrochloride** in the assay buffer.
- In a 384-well plate, add the PI3K $\alpha$  enzyme, the compound dilutions, and the PIP2 substrate.
- Initiate the kinase reaction by adding ATP.
- Incubate the plate at room temperature for a specified time (e.g., 1 hour).
- Stop the reaction and add the HTRF detection reagents.
- Incubate for another hour to allow for antibody binding.
- Measure the HTRF signal on a compatible plate reader.
- The signal is inversely proportional to the kinase activity. Calculate the IC50 value from the dose-response curve.

## Western Blot Analysis for PI3K Pathway Inhibition

This protocol assesses the effect of the inhibitor on the phosphorylation of downstream targets in the PI3K pathway, such as AKT.<sup>[1][2][4][10][11]</sup>

#### Materials:

- A549 and H661 cells
- **Flupentixol Dihydrochloride**, BYL719, BKM120
- Lysis buffer (RIPA buffer with protease and phosphatase inhibitors)
- BCA protein assay kit
- SDS-PAGE gels and running buffer
- PVDF membrane and transfer buffer
- Blocking buffer (e.g., 5% non-fat milk in TBST)
- Primary antibodies: anti-p-AKT (Ser473 and Thr308), anti-total-AKT, anti-Bcl-2, anti-GAPDH (loading control)
- HRP-conjugated secondary antibodies
- ECL substrate and imaging system

Procedure:

- Treat A549 and H661 cells with various concentrations of **Flupentixol Dihydrochloride** (e.g., 2.5, 5, 10, 15  $\mu$ M) for 24 hours.
- Lyse the cells in ice-cold lysis buffer.
- Determine the protein concentration of the lysates using a BCA assay.
- Separate equal amounts of protein on an SDS-PAGE gel and transfer to a PVDF membrane.
- Block the membrane with blocking buffer for 1 hour at room temperature.
- Incubate the membrane with primary antibodies overnight at 4°C.
- Wash the membrane and incubate with HRP-conjugated secondary antibodies for 1 hour at room temperature.

- Detect the protein bands using an ECL substrate and an imaging system.
- Quantify the band intensities and normalize the phosphorylated protein levels to total protein levels and the loading control.

## Visualizations

To further clarify the concepts and workflows, the following diagrams are provided.

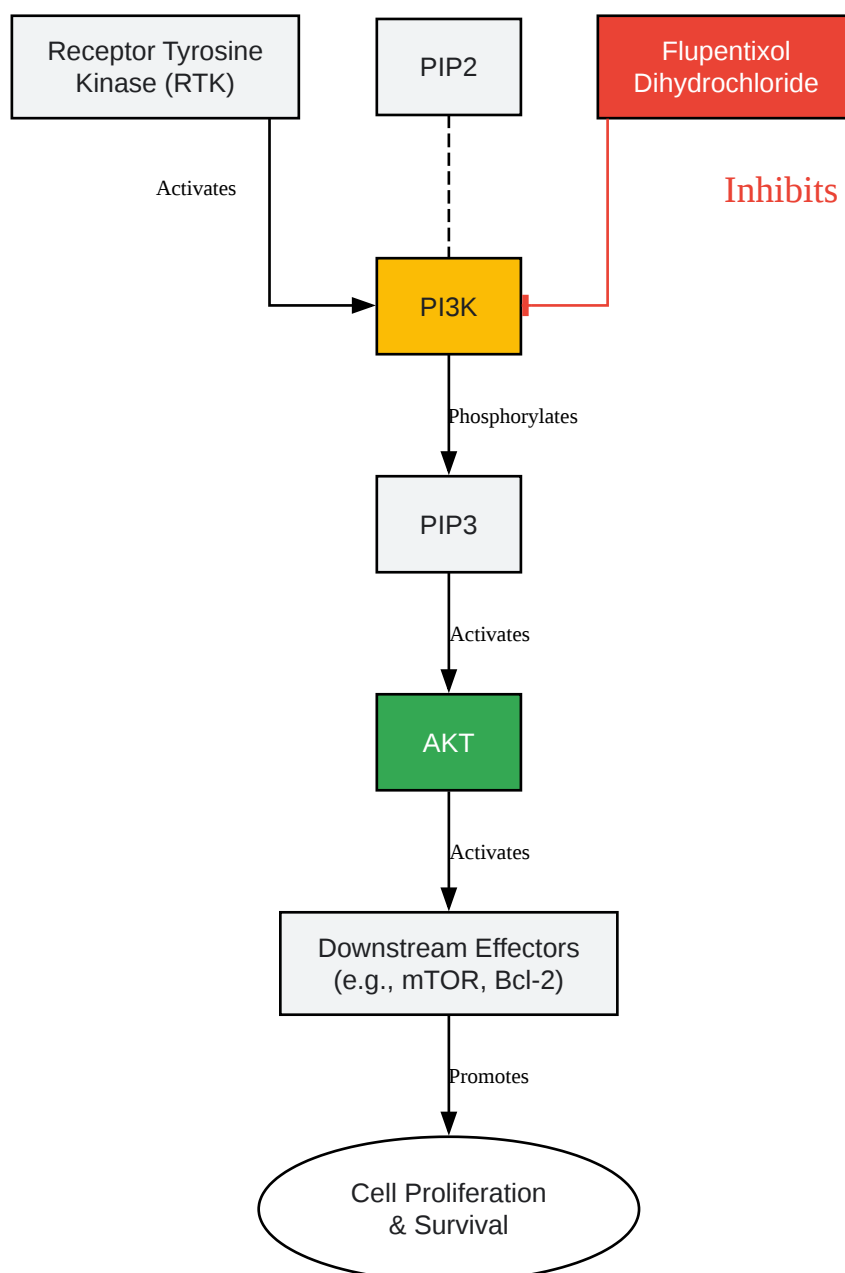

[Click to download full resolution via product page](#)

Caption: PI3K/AKT signaling pathway and the inhibitory action of **Flupentixol Dihydrochloride**.

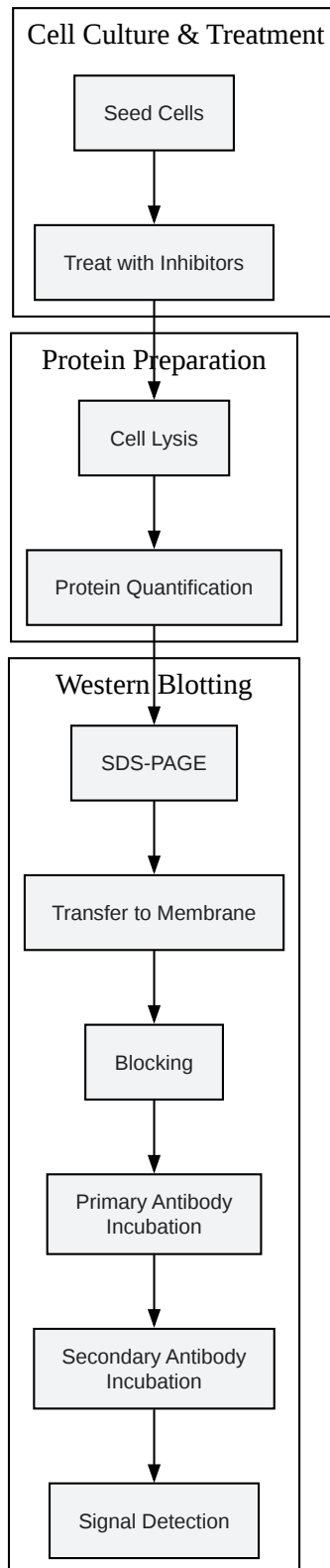

[Click to download full resolution via product page](#)

Caption: Experimental workflow for assessing PI3K pathway inhibition via Western blotting.

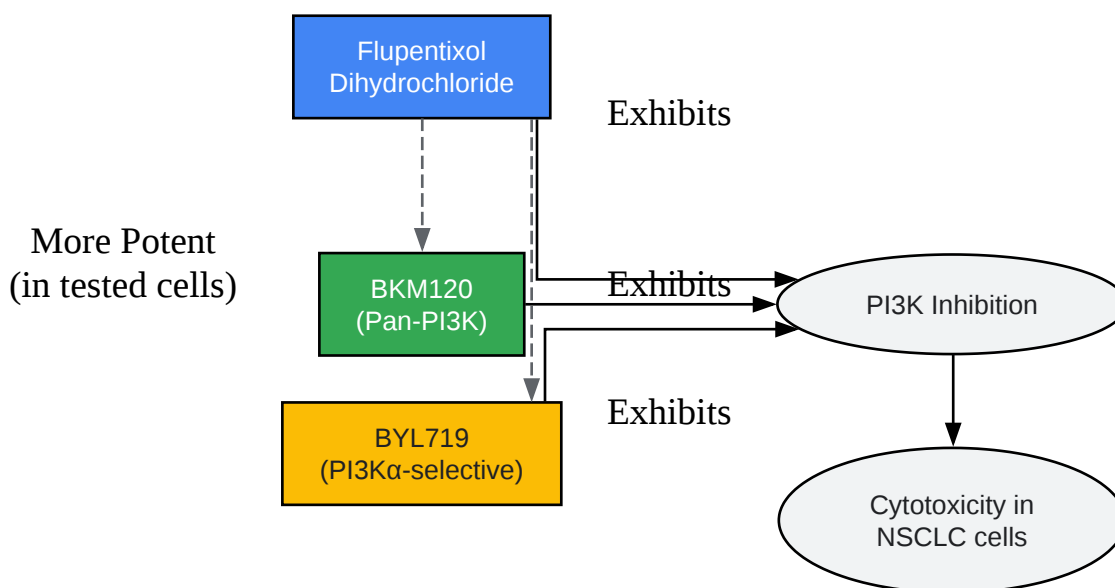

[Click to download full resolution via product page](#)

Caption: Logical relationship comparing Flupentixol to other PI3K inhibitors.

**Need Custom Synthesis?**

BenchChem offers custom synthesis for rare earth carbides and specific isotopic labeling.

Email: [info@benchchem.com](mailto:info@benchchem.com) or [Request Quote Online](#).

## References

- 1. The antipsychotic agent flupentixol is a new PI3K inhibitor and potential anticancer drug for lung cancer - PMC [pmc.ncbi.nlm.nih.gov]
- 2. The antipsychotic agent flupentixol is a new PI3K inhibitor and potential anticancer drug for lung cancer [ijbs.com]
- 3. The antipsychotic agent flupentixol is a new PI3K inhibitor and potential anticancer drug for lung cancer - PubMed [pubmed.ncbi.nlm.nih.gov]
- 4. researchgate.net [researchgate.net]



- 5. The antipsychotic agent flupentixol is a new PI3K inhibitor and potential anticancer drug for lung cancer [ijbs.com]
- 6. medchemexpress.com [medchemexpress.com]
- 7. Flupentixol dihydrochloride - Ace Therapeutics [acetherapeutics.com]
- 8. Flupentixol (dihydrochloride) - MedChem Express [bioscience.co.uk]
- 9. benchchem.com [benchchem.com]
- 10. benchchem.com [benchchem.com]
- 11. researchgate.net [researchgate.net]
- To cite this document: BenchChem. [Replicating Key Studies on Flupentixol Dihydrochloride's PI3K Inhibition: A Comparative Guide]. BenchChem, [2025]. [Online PDF]. Available at: [https://www.benchchem.com/product/b023768#replicating-key-studies-on-flupentixol-dihydrochloride-s-pi3k-inhibition]

---

#### Disclaimer & Data Validity:

The information provided in this document is for Research Use Only (RUO) and is strictly not intended for diagnostic or therapeutic procedures. While BenchChem strives to provide accurate protocols, we make no warranties, express or implied, regarding the fitness of this product for every specific experimental setup.

**Technical Support:** The protocols provided are for reference purposes. Unsure if this reagent suits your experiment? [[Contact our Ph.D. Support Team for a compatibility check](#)]

**Need Industrial/Bulk Grade?** [Request Custom Synthesis Quote](#)

## BenchChem

Our mission is to be the trusted global source of essential and advanced chemicals, empowering scientists and researchers to drive progress in science and industry.

#### Contact

Address: 3281 E Guasti Rd

Ontario, CA 91761, United States

Phone: (601) 213-4426

Email: [info@benchchem.com](mailto:info@benchchem.com)