

Refining experimental conditions for DNA ligase-IN-1 assays.

Author: BenchChem Technical Support Team. **Date:** December 2025

Compound of Interest

Compound Name: DNA ligase-IN-1

Cat. No.: B15581916

[Get Quote](#)

Technical Support Center: DNA Ligase-IN-1 Assays

This technical support center provides troubleshooting guidance and frequently asked questions (FAQs) for researchers, scientists, and drug development professionals working with **DNA ligase-IN-1** and other inhibitors of NAD⁺-dependent DNA ligases (LigA).

Frequently Asked Questions (FAQs)

Q1: What is **DNA ligase-IN-1** and what is its target?

DNA ligase-IN-1 is an inhibitor of bacterial NAD⁺-dependent DNA ligase (LigA). These enzymes are essential for bacterial DNA replication, recombination, and repair, making them a key target for the development of new antibacterial agents. Unlike the ATP-dependent DNA ligases found in eukaryotes, bacterial LigA uses nicotinamide adenine dinucleotide (NAD⁺) as a cofactor.

Q2: What is the mechanism of action of NAD⁺-dependent DNA ligase?

The ligation reaction catalyzed by NAD⁺-dependent DNA ligase occurs in three sequential steps:

- **Enzyme Adenylation:** The ligase enzyme reacts with NAD⁺, forming a covalent ligase-AMP intermediate and releasing nicotinamide mononucleotide (NMN).

- AMP Transfer: The AMP moiety is transferred from the ligase to the 5'-phosphate of the nicked DNA, creating a DNA-adenylate intermediate.
- Phosphodiester Bond Formation: The 3'-hydroxyl group at the nick attacks the DNA-adenylate, forming a phosphodiester bond to seal the nick and releasing AMP.[1][2]

Q3: How does **DNA ligase-IN-1** inhibit the enzyme?

Many inhibitors of NAD⁺-dependent DNA ligases, such as adenosine analogs, act as competitive inhibitors with respect to NAD⁺. [3][4][5] This means they bind to the NAD⁺ binding site on the enzyme, preventing the initial adenylation step and thereby blocking the entire ligation process.

Q4: What are the common assay formats for studying **DNA ligase-IN-1**?

The most common methods are fluorescence-based assays, particularly Fluorescence Resonance Energy Transfer (FRET) assays, which are well-suited for high-throughput screening (HTS). [3][6] Gel-based assays, where the ligation product is visualized on a gel, are also used but are less amenable to HTS.

Troubleshooting Guides

Fluorescence-Based (FRET) Assays

Issue 1: High Background Fluorescence

A high background signal can mask the true enzymatic activity, reducing the assay's sensitivity and dynamic range. [7]

Potential Cause	Recommended Solution
Substrate Instability/Degradation	Prepare the fluorescently labeled DNA substrate fresh for each experiment. Protect it from light to prevent photobleaching.[7][8]
Contaminated Reagents	Use high-purity water and sterile-filter the assay buffer. Test individual buffer components for intrinsic fluorescence.[7]
Test Compound Fluorescence	Run a "compound blank" control containing the buffer and test compound (without the enzyme) to measure its intrinsic fluorescence.[7]
Microplate Issues	Use black, non-transparent microplates for fluorescence assays to minimize light scatter and well-to-well crosstalk.[9][10]
Incorrect Plate Reader Settings	Ensure the excitation and emission wavelengths are set correctly for your specific fluorophores. Use appropriate cutoff filters to reduce spectral overlap.[11]

Issue 2: Low or No Signal

A weak or absent signal suggests a problem with one of the core components of the reaction.

Potential Cause	Recommended Solution
Inactive Enzyme	Ensure proper storage of the DNA ligase at -20°C. Avoid repeated freeze-thaw cycles. Test enzyme activity with a positive control.[8]
Degraded NAD+	NAD+ can be unstable. Prepare fresh solutions and store them properly. Consider quantifying the NAD+ concentration in your stock.
Suboptimal Reaction Conditions	Optimize the pH, salt concentration, and Mg ²⁺ concentration in your assay buffer. Ensure the incubation temperature is optimal for the specific ligase being used (thermostable ligases may require higher temperatures).[12]
Incorrect Substrate Design	Verify that the DNA substrate has a 5'-phosphate and a 3'-hydroxyl at the nick for ligation to occur.
Insufficient Incubation Time	Perform a time-course experiment to determine the optimal incubation time for the reaction to reach a measurable endpoint.[8]

Issue 3: Inconsistent or Non-Reproducible Results

Variability between wells or experiments can obscure the interpretation of your data.

Potential Cause	Recommended Solution
Pipetting Errors	Use calibrated pipettes and proper pipetting techniques. Prepare a master mix for the reaction components to minimize well-to-well variation.[9]
Incomplete Mixing	Gently mix all reagents upon thawing and after adding them to the reaction wells. Centrifuge the plate briefly to ensure all components are at the bottom of the wells.
Temperature Fluctuations	Ensure a consistent incubation temperature across the entire microplate. Avoid placing the plate on a cold or hot surface before reading.
Edge Effects in Microplates	Avoid using the outer wells of the microplate, as they are more prone to evaporation and temperature variations. Fill the outer wells with buffer or water.

Experimental Protocols

Protocol: FRET-Based Assay for DNA Ligase-IN-1 Inhibition

This protocol is a general guideline for a FRET-based assay to measure the inhibition of a NAD⁺-dependent DNA ligase.

1. Reagent Preparation:

- **Assay Buffer:** Prepare a 1X assay buffer. A typical composition is 50 mM Tris-HCl (pH 7.5-8.5), 5 mM MgCl₂, 1 mM DTT, and 25 mM KCl.[13][14][15]
- **DNA Substrate:** A nicked DNA substrate is created by annealing three oligonucleotides. One flanking oligo is labeled with a FRET donor (e.g., FAM) at the 3'-end, and the other is labeled with a FRET acceptor (e.g., TAMRA) at the 5'-end. The third oligonucleotide is a longer,

complementary template strand. The final concentration should be optimized, but a starting point is 40-200 nM.[3][15]

- **NAD⁺ Solution:** Prepare a stock solution of NAD⁺ in the assay buffer. A typical final concentration in the assay is between 1 μM and 26 μM.[15][16]
- **Enzyme Solution:** Prepare a working solution of the NAD⁺-dependent DNA ligase in assay buffer. The optimal concentration should be determined experimentally to ensure the reaction proceeds in the linear range.
- **Inhibitor (DNA ligase-IN-1):** Prepare a dilution series of the inhibitor in the assay buffer containing a constant, low percentage of DMSO.

2. Assay Procedure (96-well format):

- Add 2 μL of the inhibitor dilutions (or vehicle control) to the wells of a black microplate.
- Prepare a master mix containing the assay buffer, DNA substrate, and NAD⁺.
- Add 43 μL of the master mix to each well.
- Incubate the plate for 10 minutes at the optimal reaction temperature (e.g., 25°C or higher for thermostable ligases).
- Initiate the reaction by adding 5 μL of the enzyme solution to each well.
- Immediately place the plate in a fluorescence plate reader.
- Measure the fluorescence of both the donor and acceptor at appropriate intervals for 30-60 minutes.

3. Data Analysis:

- Correct for background fluorescence by subtracting the readings from "no-enzyme" control wells.
- Calculate the FRET ratio (Acceptor Emission / Donor Emission).

- Plot the initial reaction rates against the inhibitor concentration.
- Fit the data to a suitable dose-response curve to determine the IC50 value.

Data Presentation

Table 1: Typical Reaction Conditions for NAD⁺-dependent DNA Ligase Assays

Parameter	Typical Range	Notes
pH	7.5 - 9.0	The optimal pH can vary between different ligases.
Temperature	25°C - 65°C	Thermostable ligases require higher temperatures for optimal activity. [12]
Mg ²⁺ Concentration	5 - 10 mM	Divalent cations are essential for ligase activity. Mn ²⁺ can sometimes substitute for Mg ²⁺ .
NAD ⁺ Concentration	1 - 50 μM	Should be around the K _m value for NAD ⁺ for the specific enzyme.
DNA Substrate	40 - 200 nM	The concentration should be optimized for the specific assay format.

Table 2: Example Buffer Compositions

Buffer Component	Concentration	Reference
Tris-HCl	20 - 50 mM	[13][14]
Potassium Acetate/Chloride	25 - 50 mM	[13]
Magnesium Acetate/Chloride	5 - 10 mM	[13][14]
DTT	1 - 10 mM	[13][14]
NAD ⁺	1 mM	[13]
Triton® X-100	0.1%	[13]

Visualizations

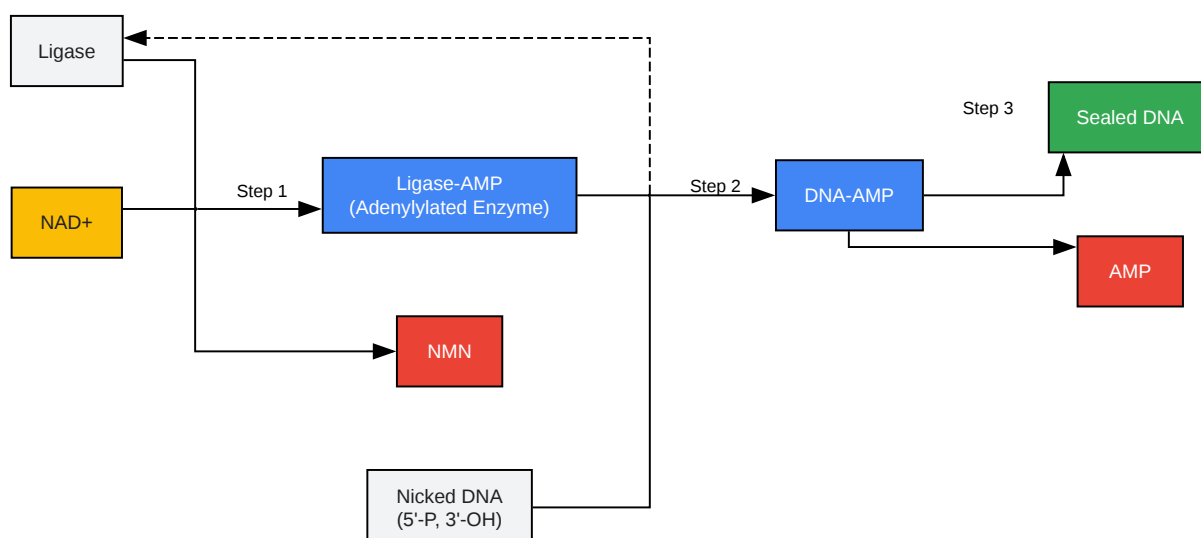

[Click to download full resolution via product page](#)

Caption: Mechanism of NAD⁺-dependent DNA Ligase.

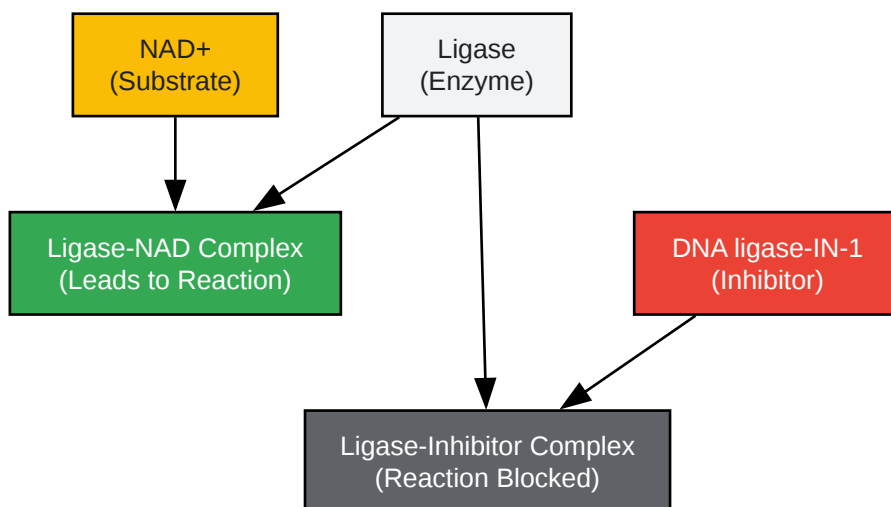

[Click to download full resolution via product page](#)

Caption: Competitive Inhibition of DNA Ligase.

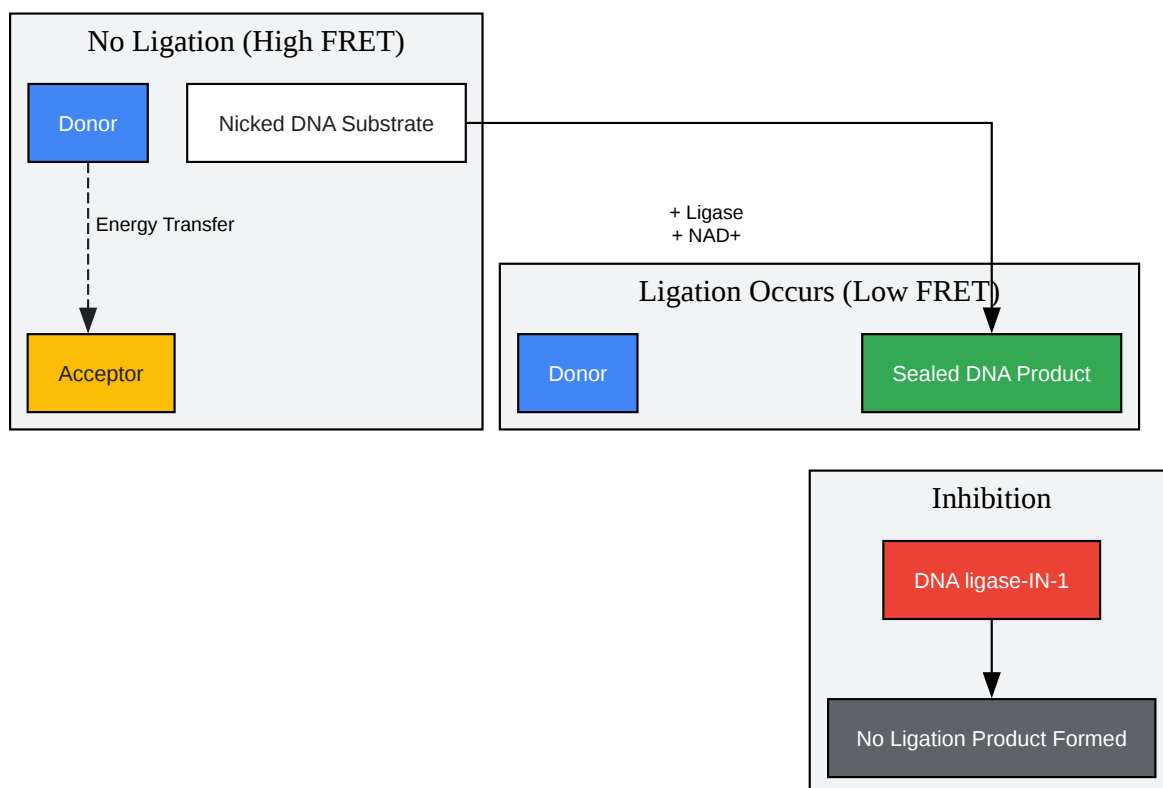

[Click to download full resolution via product page](#)

Caption: FRET Assay Principle for Ligase Inhibition.

Need Custom Synthesis?

BenchChem offers custom synthesis for rare earth carbides and specific isotopic labeling.

Email: info@benchchem.com or [Request Quote Online](#).

References

- 1. inspiralis.com [inspiralis.com]
- 2. cellbiolabs.com [cellbiolabs.com]
- 3. pcrbio.com [pcrbio.com]
- 4. Identification and characterization of an inhibitor specific to bacterial NAD⁺-dependent DNA ligases - PubMed [pubmed.ncbi.nlm.nih.gov]
- 5. Specific and potent inhibition of NAD⁺-dependent DNA ligase by pyridochromanones - PubMed [pubmed.ncbi.nlm.nih.gov]
- 6. Development of a fluorescence resonance energy transfer assay for measuring the activity of *Streptococcus pneumoniae* DNA ligase, an enzyme essential for DNA replication, repair, and recombination - PubMed [pubmed.ncbi.nlm.nih.gov]
- 7. benchchem.com [benchchem.com]
- 8. benchchem.com [benchchem.com]
- 9. docs.abcam.com [docs.abcam.com]
- 10. bitesizebio.com [bitesizebio.com]
- 11. Drug Discovery Assays Support—Troubleshooting | Thermo Fisher Scientific - JP [thermofisher.com]
- 12. Complete steady-state rate equation for DNA ligase and its use for measuring product kinetic parameters of NAD⁺-dependent DNA ligase from *Haemophilus influenzae* - PMC [pmc.ncbi.nlm.nih.gov]
- 13. neb.com [neb.com]
- 14. neb.com [neb.com]
- 15. researchgate.net [researchgate.net]

- 16. thermofisher.com [thermofisher.com]
- To cite this document: BenchChem. [Refining experimental conditions for DNA ligase-IN-1 assays.]. BenchChem, [2025]. [Online PDF]. Available at: [https://www.benchchem.com/product/b15581916#refining-experimental-conditions-for-dna-ligase-in-1-assays]

Disclaimer & Data Validity:

The information provided in this document is for Research Use Only (RUO) and is strictly not intended for diagnostic or therapeutic procedures. While BenchChem strives to provide accurate protocols, we make no warranties, express or implied, regarding the fitness of this product for every specific experimental setup.

Technical Support: The protocols provided are for reference purposes. Unsure if this reagent suits your experiment? [[Contact our Ph.D. Support Team for a compatibility check](#)]

Need Industrial/Bulk Grade? [Request Custom Synthesis Quote](#)

BenchChem

Our mission is to be the trusted global source of essential and advanced chemicals, empowering scientists and researchers to drive progress in science and industry.

Contact

Address: 3281 E Guasti Rd
Ontario, CA 91761, United States
Phone: (601) 213-4426
Email: info@benchchem.com