

# Reducing background fluorescence in Propargyl-choline imaging

**Author:** BenchChem Technical Support Team. **Date:** December 2025

## Compound of Interest

Compound Name: Propargyl-choline

Cat. No.: B8298643

[Get Quote](#)

## Technical Support Center: Propargyl-choline Imaging

Welcome to the technical support center for **propargyl-choline** imaging. This resource provides researchers, scientists, and drug development professionals with comprehensive troubleshooting guides and frequently asked questions (FAQs) to help overcome common challenges, with a specific focus on mitigating background fluorescence.

### Troubleshooting Guide

This guide addresses specific issues you may encounter during your **propargyl-choline** imaging experiments in a question-and-answer format.

Question 1: I am observing high background fluorescence across my entire sample. What are the likely causes and how can I fix this?

Answer: High, diffuse background fluorescence is a common issue that can obscure your specific signal. The primary causes fall into three categories: unbound fluorophores, sample autofluorescence, and non-specific binding of the fluorescent probe.<sup>[1][2][3]</sup>

Here is a step-by-step approach to diagnose and resolve the issue:

- Unbound Fluorophores: Incomplete removal of unbound azide- or alkyne-modified dyes after the click chemistry reaction is a frequent cause of high background.<sup>[1][2]</sup>

- Solution: Increase the number and duration of wash steps after the staining protocol. Use a buffered saline solution like PBS and perform 3-4 washes of 5-10 minutes each.[1][4] Adding a mild detergent, such as 0.2% Tween 20, to the wash buffer can also help.[4]
- Sample Autofluorescence: Biological samples contain endogenous molecules that fluoresce naturally, a phenomenon known as autofluorescence.[5][6] Common sources include collagen, elastin, flavins, and lipofuscin, which often fluoresce in the blue to green spectrum.[7][8][9] Aldehyde-based fixatives like formaldehyde and glutaraldehyde can also induce autofluorescence.[5][7]
  - Solution 1: Switch Fluorophore: Move to fluorophores that emit in the red or far-red region of the spectrum (620–750nm), where autofluorescence is typically lower.[8][10]
  - Solution 2: Use a Quenching Agent: For fixed samples, chemical quenching can be effective. Treatment with sodium borohydride can reduce aldehyde-induced autofluorescence.[5][11] Commercially available reagents like TrueBlack® can quench lipofuscin-based autofluorescence.[7][9][10]
  - Solution 3: Change Fixation Method: If possible, switch from aldehyde-based fixatives to an organic solvent like ice-cold methanol or ethanol, which may reduce autofluorescence.[8]
- Non-Specific Binding: The fluorescent dye itself may bind non-specifically to cellular components or the substrate.[2][12] This is often related to the physicochemical properties of the dye, such as hydrophobicity.[12]
  - Solution 1: Optimize Dye Concentration: Titrate the fluorescent dye to find the lowest concentration that still provides a strong specific signal, thereby minimizing non-specific interactions.[1]
  - Solution 2: Use Blocking Agents: Staining buffers containing a blocking protein like Bovine Serum Albumin (BSA) can reduce non-specific binding.[8]
  - Solution 3: Choose Dyes with Low Non-Specific Binding: Hydrophilic dyes generally show less non-specific binding to substrates than hydrophobic dyes.[12]

- **Imaging Media and Vessels:** For live-cell imaging, components in the culture medium like phenol red and fetal bovine serum (FBS) can contribute to background fluorescence.[6][8] Plastic-bottom dishes are also a known source of background.[1]
  - **Solution:** Image cells in an optically clear, phenol red-free medium or a buffered saline solution.[1][13] Use glass-bottom imaging dishes instead of plastic.[1]

Question 2: My images show a speckled or punctate background pattern. What causes this and how can I prevent it?

Answer: A speckled background is often caused by aggregates of the fluorescent dye.[2][4] Cyanine dyes, in particular, can form aggregates in aqueous solutions.[2]

- **Solution 1: Centrifuge the Dye Solution:** Before use, spin down the fluorescent dye solution in a microcentrifuge to pellet any aggregates and use the supernatant for staining.[4]
- **Solution 2: Filter the Dye Solution:** Filtering the antibody or dye solution before application can also remove aggregates.[4]
- **Solution 3: Ensure Proper Storage and Handling:** Store dyes according to the manufacturer's instructions, typically protected from light and at low temperatures, to prevent degradation and aggregation.[2]

Question 3: My specific signal is very weak compared to the background. How can I improve my signal-to-noise ratio?

Answer: A poor signal-to-noise ratio can result from either a weak specific signal or high background. Assuming you have addressed the background issues above, you can focus on amplifying your signal.

- **Solution 1: Optimize Propargyl-choline Labeling:**
  - **Concentration:** Ensure you are using an optimal concentration of **propargyl-choline**. Studies have shown a dose-dependent increase in signal with increasing **propargyl-choline** concentration.[14][15]

- Incubation Time: The incorporation of **propargyl-choline** is time-dependent. Increasing the incubation time (e.g., from 6 to 24 hours) can significantly increase the signal intensity. [\[14\]](#)
- Solution 2: Select Brighter Fluorophores: Choose fluorophores with high quantum yields and extinction coefficients. Brighter dyes like phycoerythrin (PE) or allophycocyanin (APC) can help distinguish the signal from the background.[\[8\]](#)
- Solution 3: Optimize Click Chemistry Reaction:
  - Copper(I) Catalyst (for CuAAC): The Cu(I) catalyst is essential for the copper-catalyzed azide-alkyne cycloaddition (CuAAC). Ensure it is fresh and not oxidized. Using a stabilizing ligand can improve reaction efficiency and protect biomolecules.[\[16\]](#)[\[17\]](#)
  - Reaction Time: Allow sufficient time for the click reaction to proceed to completion.
- Solution 4: Adjust Imaging Parameters: While high laser power and long exposure times can increase background, they are also necessary to detect the signal. Find the optimal balance where the specific signal is clearly visible without excessively increasing the background noise.[\[2\]](#)

## Logical Troubleshooting Workflow for High Background Fluorescence

The following diagram outlines a systematic approach to identifying and resolving the source of high background fluorescence in your experiments.

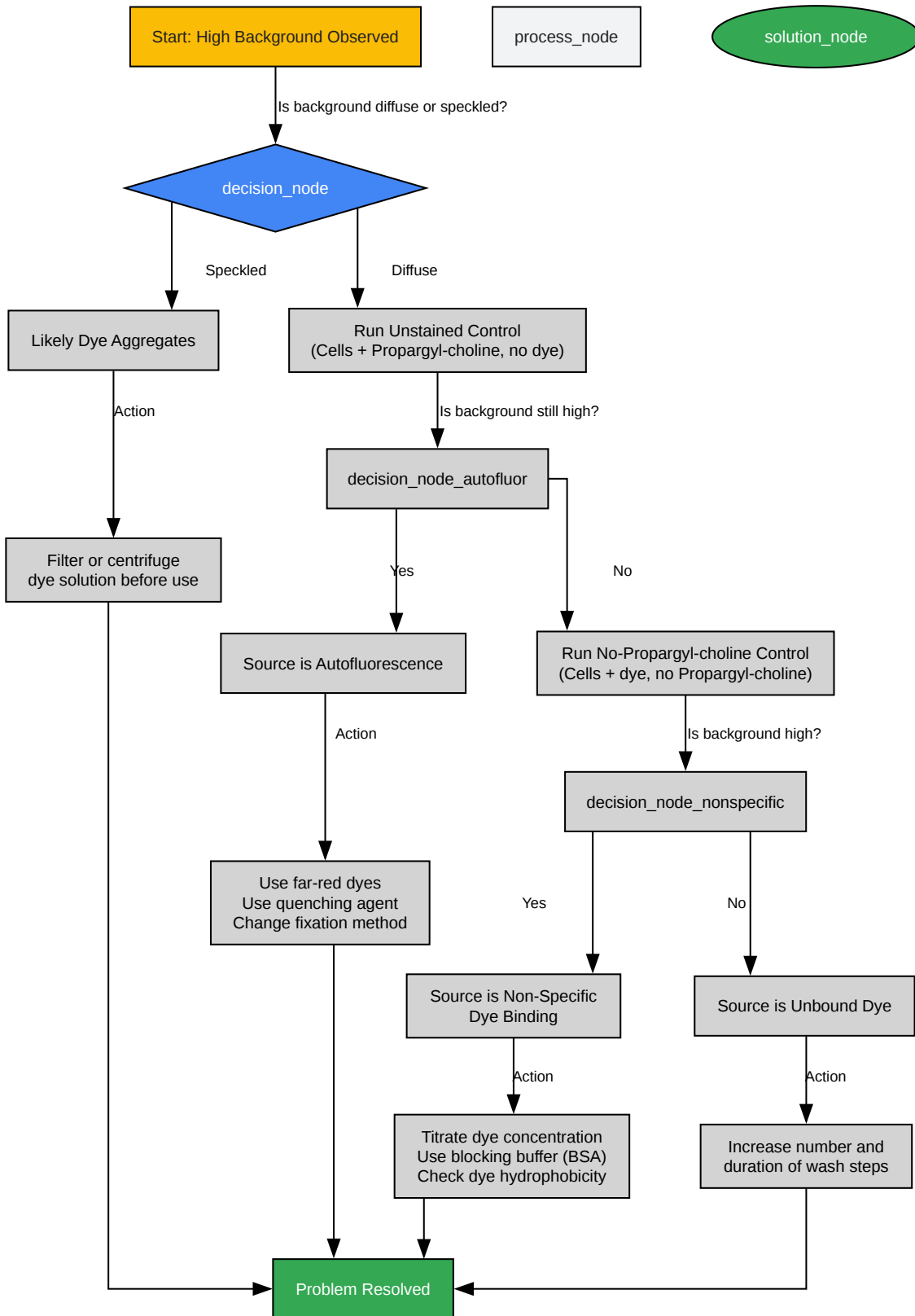

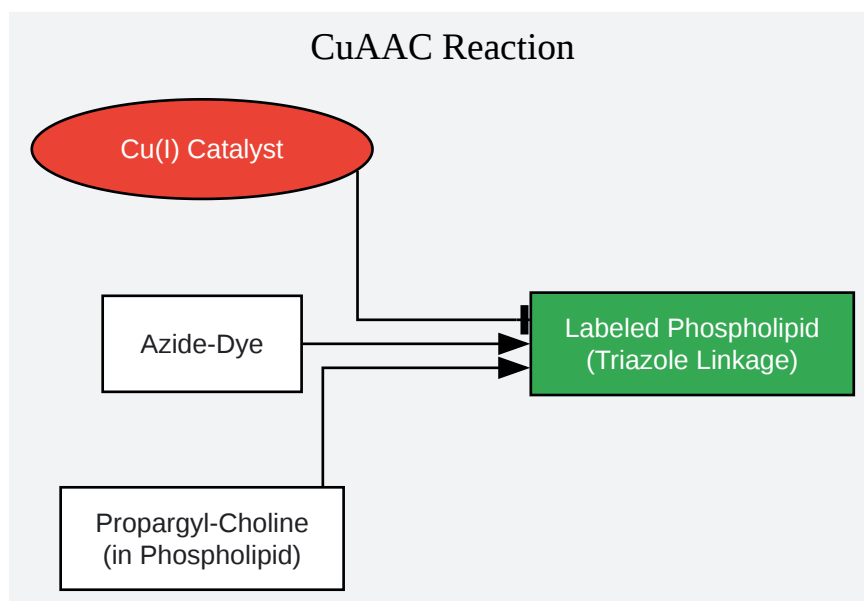
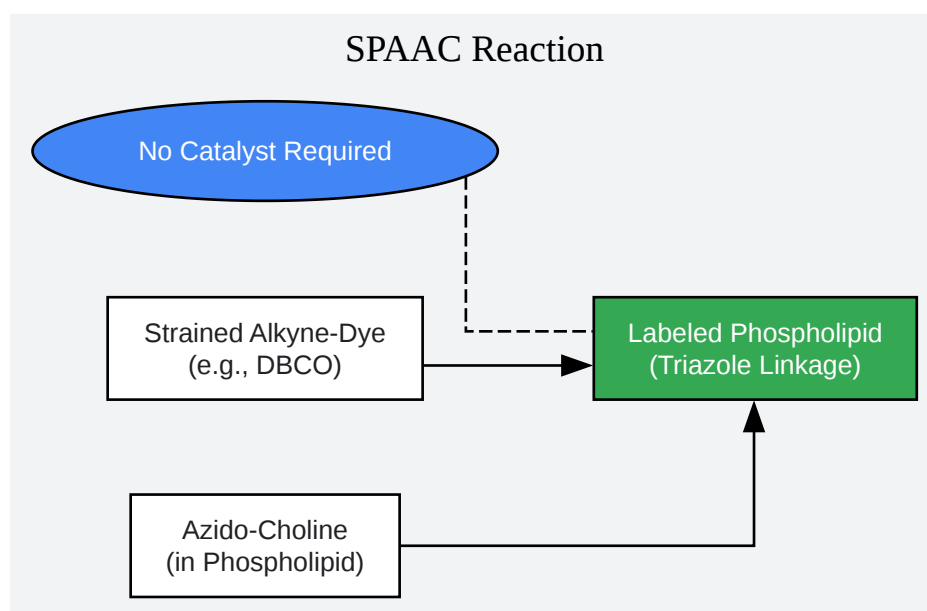

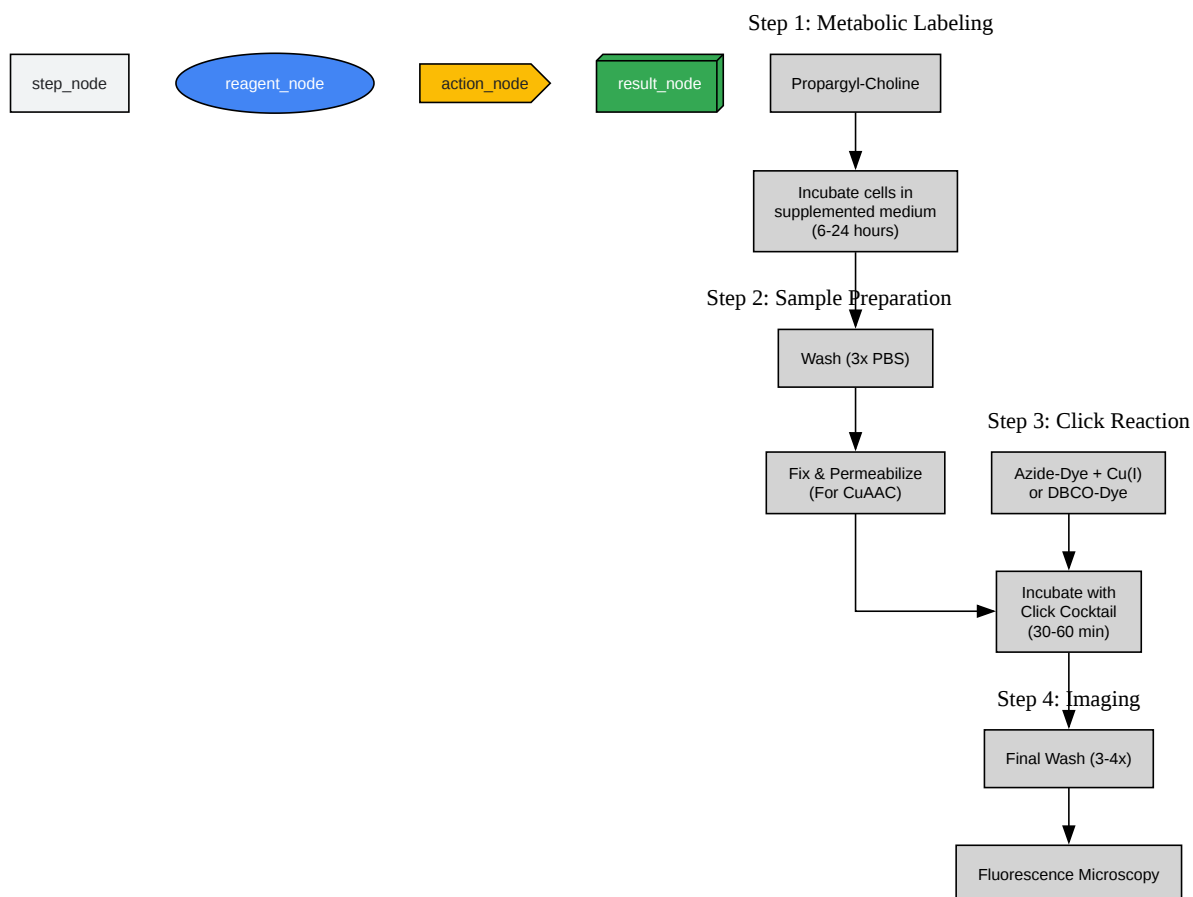

[Click to download full resolution via product page](#)

### Need Custom Synthesis?

BenchChem offers custom synthesis for rare earth carbides and specific isotopic labeling.

Email: [info@benchchem.com](mailto:info@benchchem.com) or [Request Quote Online](#).

## References

- 1. Background in Fluorescence Imaging | Thermo Fisher Scientific - SG [thermofisher.com]
- 2. benchchem.com [benchchem.com]
- 3. Background in Fluorescence Imaging | Thermo Fisher Scientific - US [thermofisher.com]
- 4. m.youtube.com [m.youtube.com]
- 5. How to reduce autofluorescence | Proteintech Group [ptglab.com]
- 6. Learn how to Remove Autofluorescence from your Confocal Images | Learn & Share | Leica Microsystems [leica-microsystems.com]
- 7. Amplification and Background Reduction Techniques | FluoroFinder [fluorofinder.com]
- 8. Tips to Minimize Autofluorescence - FluoroFinder [fluorofinder.com]
- 9. Stepping Out of the Background | The Scientist [the-scientist.com]
- 10. biotium.com [biotium.com]
- 11. benchchem.com [benchchem.com]
- 12. clf.stfc.ac.uk [clf.stfc.ac.uk]
- 13. researchgate.net [researchgate.net]
- 14. pnas.org [pnas.org]
- 15. Metabolic labeling and direct imaging of choline phospholipids in vivo - PMC [pmc.ncbi.nlm.nih.gov]
- 16. Copper-Catalyzed Azide–Alkyne Cycloaddition (CuAAC) by Functionalized NHC-Based Polynuclear Catalysts: Scope and Mechanistic Insights - PMC [pmc.ncbi.nlm.nih.gov]
- 17. Copper-Catalyzed Azide–Alkyne Click Chemistry for Bioconjugation - PMC [pmc.ncbi.nlm.nih.gov]
- To cite this document: BenchChem. [Reducing background fluorescence in Propargyl-choline imaging]. BenchChem, [2025]. [Online PDF]. Available at:



[<https://www.benchchem.com/product/b8298643#reducing-background-fluorescence-in-propargyl-choline-imaging>]

---

### Disclaimer & Data Validity:

The information provided in this document is for Research Use Only (RUO) and is strictly not intended for diagnostic or therapeutic procedures. While BenchChem strives to provide accurate protocols, we make no warranties, express or implied, regarding the fitness of this product for every specific experimental setup.

**Technical Support:** The protocols provided are for reference purposes. Unsure if this reagent suits your experiment? [[Contact our Ph.D. Support Team for a compatibility check](#)]

**Need Industrial/Bulk Grade?** [Request Custom Synthesis Quote](#)

## BenchChem

Our mission is to be the trusted global source of essential and advanced chemicals, empowering scientists and researchers to drive progress in science and industry.

### Contact

Address: 3281 E Guasti Rd  
Ontario, CA 91761, United States  
Phone: (601) 213-4426  
Email: [info@benchchem.com](mailto:info@benchchem.com)