

Reactivity of Iodocyclopentane with Common Nucleophiles: An In-depth Technical Guide

Author: BenchChem Technical Support Team. **Date:** December 2025

Compound of Interest

Compound Name: Iodocyclopentane

Cat. No.: B073287

[Get Quote](#)

For Researchers, Scientists, and Drug Development Professionals

This technical guide provides a comprehensive overview of the reactivity of **iodocyclopentane** with a range of common nucleophiles. **Iodocyclopentane**, as a secondary alkyl iodide, serves as a versatile substrate in nucleophilic substitution and elimination reactions, which are fundamental transformations in organic synthesis and crucial for the construction of novel pharmaceutical agents. This document details the mechanistic pathways, influencing factors, and expected product distributions, supported by illustrative tables, representative experimental protocols, and mechanistic diagrams.

Core Principles of Iodocyclopentane Reactivity

Iodocyclopentane's reactivity is primarily governed by the competition between substitution (SN1 and SN2) and elimination (E1 and E2) pathways. The outcome of its reaction with a nucleophile is dictated by several key factors: the nature of the nucleophile, the solvent, the temperature, and the steric environment of the substrate.

Leaving Group Ability: The iodide ion (I^-) is an excellent leaving group due to its large size, high polarizability, and the relatively weak carbon-iodine bond. This inherent property facilitates both substitution and elimination reactions.

Substrate Structure: As a secondary alkyl halide, **iodocyclopentane** is susceptible to both SN2 and E2 reactions. Steric hindrance around the electrophilic carbon is moderate, allowing for backside attack by nucleophiles in SN2 reactions, while also being conducive to the formation

of a stable carbocation intermediate in SN1 reactions under appropriate conditions. The presence of β -hydrogens allows for E2 elimination.

Reaction Mechanisms and Influencing Factors

The interplay of various factors determines the predominant reaction mechanism.

Nucleophilic Substitution (SN1 and SN2)

- SN2 (Bimolecular Nucleophilic Substitution): This is a single-step, concerted mechanism where a strong nucleophile attacks the electrophilic carbon from the backside, leading to an inversion of stereochemistry. The rate of an SN2 reaction is dependent on the concentration of both the substrate and the nucleophile. For **iodocyclopentane**, SN2 reactions are favored by strong, weakly basic nucleophiles and polar aprotic solvents.[1]
- SN1 (Unimolecular Nucleophilic Substitution): This is a two-step mechanism involving the formation of a carbocation intermediate. The rate-determining step is the unimolecular dissociation of the leaving group. SN1 reactions are favored by polar protic solvents, which can stabilize the carbocation intermediate, and by weak nucleophiles.

Elimination (E1 and E2)

- E2 (Bimolecular Elimination): This is a single-step, concerted mechanism where a strong base removes a β -hydrogen, leading to the formation of a double bond and the simultaneous departure of the leaving group. The rate is dependent on the concentration of both the substrate and the base. Strong, bulky bases favor E2 reactions.[2][3]
- E1 (Unimolecular Elimination): This is a two-step mechanism that proceeds through a carbocation intermediate, similar to the SN1 pathway. E1 reactions are often in competition with SN1 reactions and are favored by high temperatures and the use of weak bases.

Quantitative Data Summary

While specific kinetic data for **iodocyclopentane** is not extensively available in the literature, the following tables summarize the expected reactivity and product outcomes based on established principles for secondary alkyl halides.

Table 1: Expected Predominant Reaction Pathways for **Iodocyclopentane** with Common Nucleophiles

Nucleophile/Base	Nucleophile Strength	Base Strength	Expected Major Product(s)	Predominant Mechanism(s)
I ⁻ , Br ⁻ , Cl ⁻ , RS ⁻ , N ₃ ⁻ , CN ⁻	Strong	Weak	Cyclopentyl-Nu	SN2
H ₂ O, ROH	Weak	Weak	Cyclopentanol/Cyclopentyl ether, Cyclopentene	SN1, E1
OH ⁻ , RO ⁻	Strong	Strong	Cyclopentene, Methoxycyclopentane	E2, SN2
t-BuO ⁻	Weak	Strong, Bulky	Cyclopentene	E2
RCOO ⁻	Moderate	Moderate	Cyclopentyl ester	SN2
NH ₃ , RNH ₂	Moderate	Moderate	Cyclopentylamine	SN2

Table 2: Influence of Reaction Conditions on Product Distribution

Condition	Favoring SN2	Favoring SN1	Favoring E2	Favoring E1
Nucleophile/Base	Strong, weakly basic	Weak	Strong, bulky	Weak
Solvent	Polar aprotic (e.g., DMSO, Acetone)	Polar protic (e.g., H ₂ O, EtOH)	Polar protic (e.g., EtOH)	Polar protic (e.g., H ₂ O, EtOH)
Temperature	Low	Low	High	High
Substrate Conc.	High	Low	High	Low
Nucleophile Conc.	High	Low	High	Low

Experimental Protocols

The following are representative experimental protocols for key reactions of **iodocyclopentane**.

SN2 Reaction: Synthesis of Cyclopentyl Azide

Objective: To synthesize cyclopentyl azide from **iodocyclopentane** via an SN2 reaction.

Materials:

- **Iodocyclopentane**
- Sodium azide (NaN₃)
- Dimethylformamide (DMF)
- Diethyl ether
- Saturated aqueous sodium bicarbonate solution
- Brine
- Anhydrous magnesium sulfate

Procedure:

- In a round-bottom flask equipped with a magnetic stirrer and a reflux condenser, dissolve **iodocyclopentane** (1.0 eq) in DMF.
- Add sodium azide (1.2 eq) to the solution.
- Heat the reaction mixture to 60-70 °C and stir for 12-24 hours, monitoring the reaction progress by TLC.
- After completion, cool the reaction mixture to room temperature and pour it into a separatory funnel containing water.
- Extract the aqueous layer with diethyl ether (3 x 50 mL).
- Combine the organic layers and wash with saturated aqueous sodium bicarbonate solution, followed by brine.
- Dry the organic layer over anhydrous magnesium sulfate, filter, and concentrate under reduced pressure to yield the crude product.
- Purify the crude product by column chromatography on silica gel.

E2 Reaction: Synthesis of Cyclopentene

Objective: To synthesize cyclopentene from **iodocyclopentane** via an E2 elimination.

Materials:

- **Iodocyclopentane**
- Potassium tert-butoxide (t-BuOK)
- tert-Butanol
- Pentane
- Water

- Brine
- Anhydrous sodium sulfate

Procedure:

- In a flame-dried round-bottom flask under an inert atmosphere, dissolve potassium tert-butoxide (1.5 eq) in anhydrous tert-butanol.
- Cool the solution in an ice bath and add a solution of **iodocyclopentane** (1.0 eq) in tert-butanol dropwise.
- Allow the reaction mixture to warm to room temperature and stir for 2-4 hours.
- Monitor the reaction by GC-MS for the formation of cyclopentene.
- Quench the reaction by adding water.
- Extract the mixture with pentane (3 x 30 mL).
- Combine the organic layers and wash with water and then brine.
- Dry the organic layer over anhydrous sodium sulfate, filter, and carefully distill to isolate the volatile cyclopentene.

Visualizations of Reaction Pathways and Workflows

Reaction Mechanisms

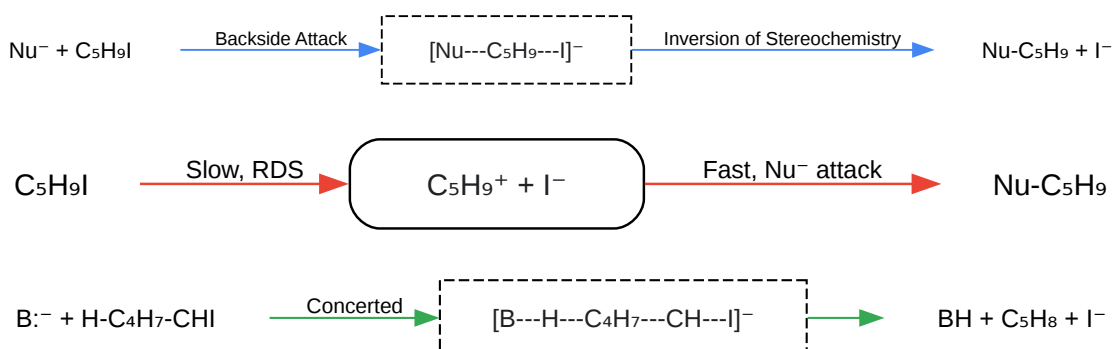

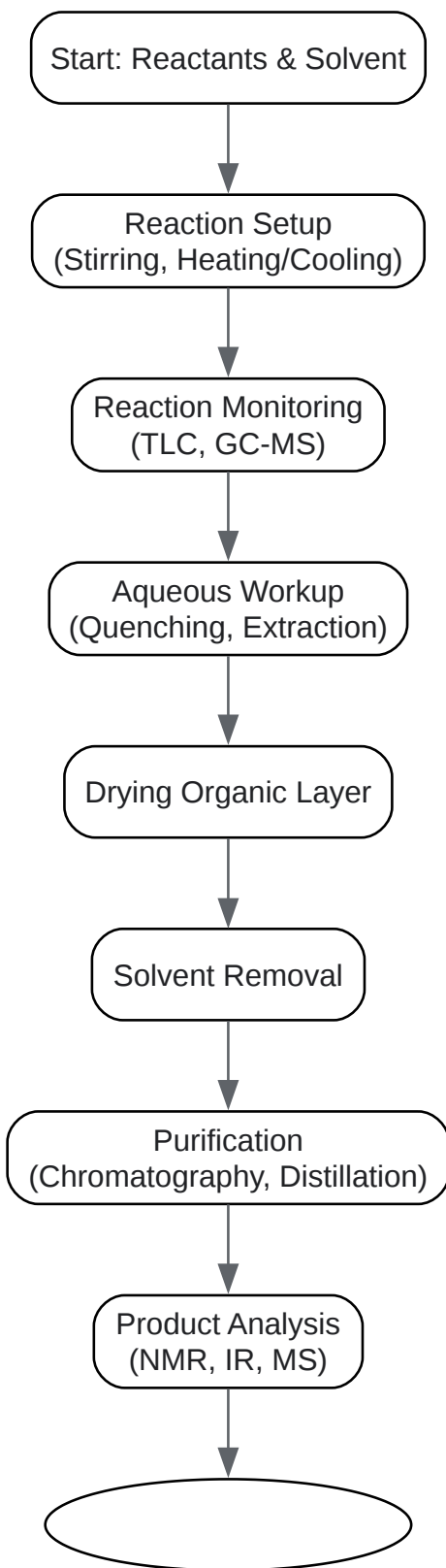
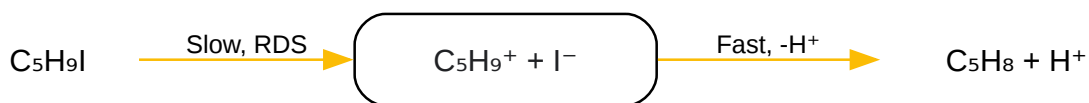

[Click to download full resolution via product page](#)

Need Custom Synthesis?

BenchChem offers custom synthesis for rare earth carbides and specific isotopic labeling.

Email: info@benchchem.com or [Request Quote Online](#).

References

- 1. masterorganicchemistry.com [masterorganicchemistry.com]
- 2. masterorganicchemistry.com [masterorganicchemistry.com]
- 3. tBuOK Elimination - Chemistry Steps [chemistrysteps.com]
- To cite this document: BenchChem. [Reactivity of Iodocyclopentane with Common Nucleophiles: An In-depth Technical Guide]. BenchChem, [2025]. [Online PDF]. Available at: [https://www.benchchem.com/product/b073287#iodocyclopentane-reactivity-with-common-nucleophiles]

Disclaimer & Data Validity:

The information provided in this document is for Research Use Only (RUO) and is strictly not intended for diagnostic or therapeutic procedures. While BenchChem strives to provide accurate protocols, we make no warranties, express or implied, regarding the fitness of this product for every specific experimental setup.

Technical Support: The protocols provided are for reference purposes. Unsure if this reagent suits your experiment? [[Contact our Ph.D. Support Team for a compatibility check](#)]

Need Industrial/Bulk Grade? [Request Custom Synthesis Quote](#)

BenchChem

Our mission is to be the trusted global source of essential and advanced chemicals, empowering scientists and researchers to drive progress in science and industry.

Contact

Address: 3281 E Guasti Rd

Ontario, CA 91761, United States

Phone: (601) 213-4426

Email: info@benchchem.com