

Protocol for Using Thiostrepton as a Selective Agent

Author: BenchChem Technical Support Team. **Date:** December 2025

Compound of Interest

Compound Name: Thiostrepton

Cat. No.: B1575682

[Get Quote](#)

For Researchers, Scientists, and Drug Development Professionals

These application notes provide a comprehensive guide for the use of **thiostrepton** as a selective agent in microbiological research. This document includes detailed information on its mechanism of action, protocols for the preparation of stock solutions and selective media, and recommended concentrations for various bacterial species.

Mechanism of Action

Thiostrepton is a thiopeptide antibiotic that inhibits protein synthesis in prokaryotes. Its primary mode of action involves binding to the 50S ribosomal subunit, specifically to a region composed of 23S rRNA and the ribosomal protein L11.[1][2] This binding event sterically hinders the association of elongation factors, such as EF-G and EF-Tu, with the ribosome.[2][3][4] Consequently, the GTPase activity required for the translocation of tRNA and mRNA is inhibited, leading to a cessation of protein synthesis.[2][4] While its most studied effect is on elongation, **thiostrepton** can also interfere with the initiation and termination phases of translation.[2][3]

Resistance to **thiostrepton** can be conferred by the *tsr* gene, which encodes a 23S rRNA methyltransferase. This enzyme modifies the ribosome, preventing the binding of **thiostrepton**. [5] Mutations in the gene for ribosomal protein L11 can also lead to resistance.[6]

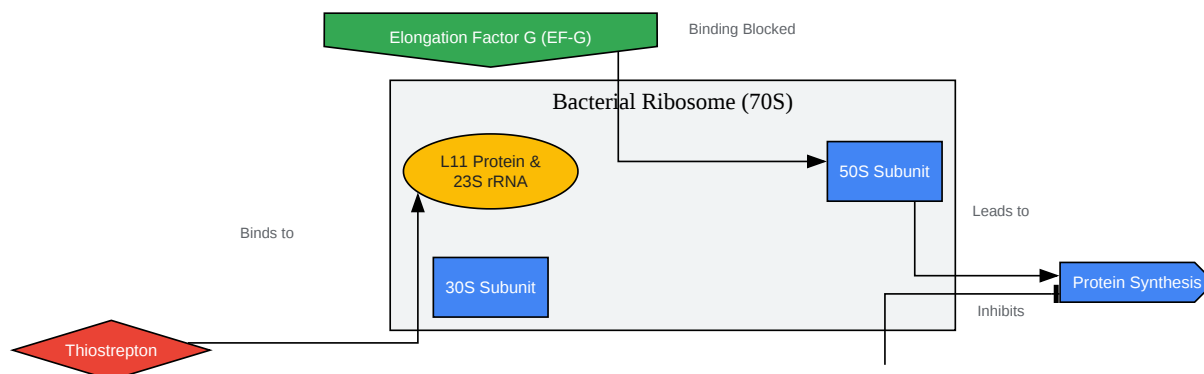

[Click to download full resolution via product page](#)

Caption: Mechanism of action of **Thiostrepton**.

Quantitative Data

The following tables summarize the recommended concentrations for **thiostrepton** stock solutions and the Minimum Inhibitory Concentrations (MICs) for various bacteria.

Table 1: **Thiostrepton** Stock Solution and Storage

Parameter	Recommendation
Solvent	Dimethyl sulfoxide (DMSO)[7]
Stock Concentration	50 mg/mL[7]
Storage Temperature	-20°C[8][9]
Stability of Stock	Up to 1 month at -20°C, up to 6 months at -80°C[9]
Note	Thiostrepton has low aqueous solubility.[2] For aqueous buffers, first dissolve in a small amount of DMSO or DMF and then dilute.[8]

Table 2: Minimum Inhibitory Concentration (MIC) of **Thiostrepton** for Various Bacteria

Organism	Strain	MIC ($\mu\text{g/mL}$)	Reference
Neisseria gonorrhoeae	T9	< 1	[10]
Pseudomonas aeruginosa	PAO1	~17 (in 10:90 medium)	[11]
Pseudomonas aeruginosa	Clinical Isolates	8.3 (5 μM)	[11]
Acinetobacter baumannii	Clinical Isolates	8.3 (5 μM)	[11]
Geobacillus kaustophilus	HTA426	Effective at 50 $\mu\text{g/mL}$	[12]
Streptomyces spp.	General	50	[7]
Escherichia coli	General	Generally considered resistant	[10]

Experimental Protocols

Preparation of Thiostrepton Stock Solution (50 mg/mL)

- Weigh out 50 mg of **thiostrepton** powder in a sterile conical tube.
- Add 1 mL of 100% DMSO.[7]
- Vortex thoroughly until the **thiostrepton** is completely dissolved.
- Aliquot the stock solution into sterile microcentrifuge tubes.
- Store the aliquots at -20°C or -80°C , protected from light.[9][13]

Preparation of Thiostrepton Selective Agar Plates

- Prepare the desired agar medium (e.g., LB agar, Nutrient Agar) according to the manufacturer's instructions and autoclave.
- Cool the autoclaved medium to 50-60°C in a water bath.[14][15] This is crucial to prevent the degradation of the antibiotic.
- Thaw an aliquot of the **thiostrepton** stock solution.
- Add the appropriate volume of the **thiostrepton** stock solution to the cooled agar to achieve the desired final concentration (e.g., for a final concentration of 50 µg/mL, add 1 mL of a 50 mg/mL stock solution to 1 L of medium).
- Swirl the flask gently to ensure thorough mixing of the antibiotic without introducing air bubbles.[15]
- Aseptically pour the agar into sterile petri dishes (approximately 20-25 mL per plate).
- Allow the plates to solidify at room temperature.
- Once solidified, store the plates inverted at 4°C until use.

Protocol for Selection of Thiostrepton-Resistant Transformants

This protocol outlines the selection of bacterial colonies that have been transformed with a plasmid conferring **thiostrepton** resistance.

3.3.1. Materials

- **Thiostrepton** selective agar plates (prepared as in section 3.2)
- Non-selective agar plates (control)
- Transformed bacterial culture
- Untransformed (wild-type) bacterial culture (negative control)
- Bacterial culture known to be resistant to **thiostrepton** (positive control, if available)

- Sterile spreader or plating beads
- Incubator

3.3.2. Procedure

- Thaw the transformed bacterial cells on ice.
- Plate 100-200 μL of the transformed cell suspension onto a pre-warmed **thiostrepton** selective agar plate.
- Using a sterile spreader, evenly distribute the cell suspension across the surface of the agar.
- Controls:
 - Negative Control: Plate the same volume of untransformed (wild-type) cells onto a **thiostrepton** selective agar plate. This is to ensure that the selection is effective and that there is no spontaneous resistance.
 - Positive Control (Transformation Efficiency): Plate a small volume (e.g., 10-20 μL) of the transformed cells onto a non-selective agar plate. This will allow you to calculate the transformation efficiency and confirm the viability of the cells.
 - Positive Control (Antibiotic Activity): If available, streak a known **thiostrepton**-resistant strain on a selective plate to confirm the antibiotic is active.
- Incubate all plates at the optimal growth temperature for the bacterial species until colonies are visible (typically 16-24 hours).
- Expected Results:
 - Selective Plate with Transformants: Growth of colonies is expected.
 - Selective Plate with Untransformed Cells (Negative Control): No growth or only satellite colonies should be observed.
 - Non-selective Plate with Transformants (Positive Control): A lawn of growth or a high density of colonies should be visible.

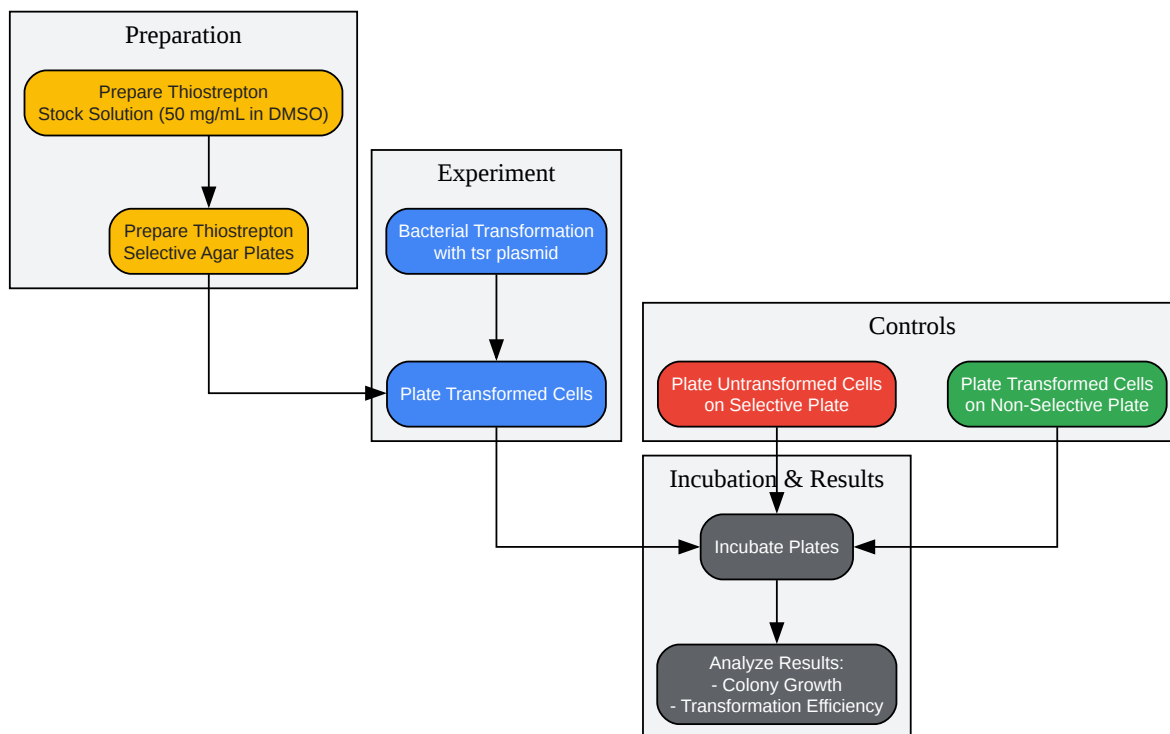

[Click to download full resolution via product page](#)

Caption: Experimental workflow for **thioestrepton** selection.

Need Custom Synthesis?

BenchChem offers custom synthesis for rare earth carbides and specific isotopic labeling.

Email: info@benchchem.com or [Request Quote Online](#).

References

- 1. Ribosome-Targeting Antibiotics: Modes of Action, Mechanisms of Resistance, and Implications for Drug Design - PMC [pmc.ncbi.nlm.nih.gov]
- 2. Thiostrepton inhibits stable 70S ribosome binding and ribosome-dependent GTPase activation of elongation factor G and elongation factor 4 - PMC [pmc.ncbi.nlm.nih.gov]
- 3. The mode of action of thiostrepton in the initiation of protein synthesis - PubMed [pubmed.ncbi.nlm.nih.gov]
- 4. The Mechanisms of Action of Ribosome-Targeting Peptide Antibiotics - PMC [pmc.ncbi.nlm.nih.gov]
- 5. The thiostrepton-resistance-encoding gene in *Streptomyces laurentii* is located within a cluster of ribosomal protein operons - PubMed [pubmed.ncbi.nlm.nih.gov]
- 6. Thiostrepton - Wikipedia [en.wikipedia.org]
- 7. Antibiotic stocks and working concentrations - ActinoBase [actinobase.org]
- 8. cdn.caymanchem.com [cdn.caymanchem.com]
- 9. medchemexpress.com [medchemexpress.com]
- 10. Thiostrepton, a resurging drug inhibiting the stringent response to counteract antibiotic-resistance and expression of virulence determinants in *Neisseria gonorrhoeae* - PMC [pmc.ncbi.nlm.nih.gov]
- 11. Thiostrepton Hijacks Pyoverdine Receptors To Inhibit Growth of *Pseudomonas aeruginosa* - PMC [pmc.ncbi.nlm.nih.gov]
- 12. A thiostrepton resistance gene and its mutants serve as selectable markers in *Geobacillus kaustophilus* HTA426 - PubMed [pubmed.ncbi.nlm.nih.gov]
- 13. boneandcancer.org [boneandcancer.org]
- 14. static.igem.wiki [static.igem.wiki]
- 15. static.igem.org [static.igem.org]
- To cite this document: BenchChem. [Protocol for Using Thiostrepton as a Selective Agent]. BenchChem, [2025]. [Online PDF]. Available at: [https://www.benchchem.com/product/b1575682#protocol-for-using-thiostrepton-as-a-selective-agent]

Disclaimer & Data Validity:

The information provided in this document is for Research Use Only (RUO) and is strictly not intended for diagnostic or therapeutic procedures. While BenchChem strives to provide

accurate protocols, we make no warranties, express or implied, regarding the fitness of this product for every specific experimental setup.

Technical Support: The protocols provided are for reference purposes. Unsure if this reagent suits your experiment? [[Contact our Ph.D. Support Team for a compatibility check](#)]

Need Industrial/Bulk Grade? [Request Custom Synthesis Quote](#)

BenchChem

Our mission is to be the trusted global source of essential and advanced chemicals, empowering scientists and researchers to drive progress in science and industry.

Contact

Address: 3281 E Guasti Rd

Ontario, CA 91761, United States

Phone: (601) 213-4426

Email: info@benchchem.com