

Preventing racemization of Fmoc-Tyr(Bzl)-OH during activation

Author: BenchChem Technical Support Team. **Date:** December 2025

Compound of Interest

Compound Name: *N-Fmoc-O-benzyl-L-tyrosine*

Cat. No.: B557360

[Get Quote](#)

Technical Support Center: Peptide Synthesis

Topic: Preventing Racemization of Fmoc-Tyr(Bzl)-OH During Activation

This guide provides troubleshooting advice and frequently asked questions (FAQs) to help researchers, scientists, and drug development professionals minimize or eliminate racemization of Fmoc-Tyr(Bzl)-OH during the activation step of peptide synthesis.

Frequently Asked Questions (FAQs)

Q1: What is racemization in the context of peptide synthesis and why is it a concern for Fmoc-Tyr(Bzl)-OH?

A1: Racemization is the loss of stereochemical integrity at the alpha-carbon of an amino acid, leading to the formation of its D-isomer from the L-isomer (or vice versa). During peptide synthesis, the activation of the carboxyl group of an N-protected amino acid makes the alpha-proton more acidic and susceptible to abstraction by a base. This can lead to the formation of a planar enolate intermediate, which upon re-protonation can yield a mixture of both D and L enantiomers. Urethane-based protecting groups like Fmoc are designed to suppress racemization.^[1] However, certain amino acids, especially when activated for a prolonged period in the presence of a base, can still be susceptible. For Fmoc-Tyr(Bzl)-OH, this is a critical issue as the presence of the D-Tyr(Bzl) diastereomer in the final peptide can be difficult to remove and can significantly impact the peptide's biological activity and structural properties.

Q2: How does the choice of coupling reagent affect the racemization of Fmoc-Tyr(Bzl)-OH?

A2: The coupling reagent plays a pivotal role in the rate of racemization. Highly reactive reagents can accelerate peptide bond formation, which is desirable, but they can also increase the risk of racemization if the activation is not well-controlled. Coupling reagents are broadly classified into carbodiimides, phosphonium salts, and aminium/uronium salts. For sensitive amino acids, the use of additives that suppress racemization is crucial, especially with carbodiimides.[2]

Q3: What are racemization-suppressing additives and how do they work?

A3: Additives such as 1-hydroxybenzotriazole (HOBt), 1-hydroxy-7-azabenzotriazole (HOAt), and ethyl (hydroxyimino)cyanoacetate (OxymaPure®) are frequently used to minimize racemization.[3][4] When mixed with a coupling reagent like a carbodiimide, these additives form active esters with the Fmoc-amino acid. These active esters are more stable and less prone to racemization than the intermediates formed with the coupling reagent alone, while still being reactive enough to form the peptide bond.[2] HOAt and OxymaPure are generally considered more effective than HOBt in suppressing racemization.[4]

Q4: Can the base used during the coupling reaction influence racemization?

A4: Absolutely. The base is necessary to activate the Fmoc-amino acid, but it is also the primary culprit in abstracting the alpha-proton, which initiates racemization. The strength and steric hindrance of the base are important factors. Stronger and less sterically hindered bases can increase the rate of racemization. Therefore, for racemization-prone residues, it is advisable to use weaker or more hindered bases.[4]

Q5: Does the benzyl (Bzl) protecting group on the tyrosine side chain influence racemization?

A5: The primary role of the benzyl group is to protect the phenolic hydroxyl group of tyrosine from side reactions. While the electronic properties of the side chain can have a minor influence on the acidity of the alpha-proton, the main factors driving racemization during the activation step are the choice of coupling reagent, base, temperature, and activation time. The benzyl group itself is generally stable during coupling but can be prone to other side reactions, such as migration, under strongly acidic conditions during final cleavage.[5]

Troubleshooting Guide

Issue: High levels of D-Tyr(Bzl) diastereomer detected in the synthesized peptide.

This is a common issue that can often be resolved by systematically evaluating and optimizing the coupling conditions. Follow the steps below to troubleshoot and minimize racemization.

Step 1: Evaluate Your Coupling Reagent and Additive Combination

The choice of coupling reagent and additive is the most critical factor in controlling racemization.

Recommendations:

- If using carbodiimides (e.g., DIC, DCC): It is essential to use an additive.^[2] Consider switching from HOBt to the more effective HOAt or OxymaPure.
- If using phosphonium or aminium/uronium salts (e.g., HBTU, HATU, PyBOP): These reagents already contain a benzotriazole moiety and are generally considered "low-racemization." However, for particularly sensitive couplings, ensure that the pre-activation time is minimized. Reagents like HATU (which is based on HOAt) or those used with OxymaPure may offer superior performance in suppressing racemization.^[4]

Table 1: Qualitative Comparison of Coupling Reagent Classes for Fmoc-Tyr(Bzl)-OH

Reagent Class	Examples	Propensity for Racemization (without additives)	Recommendation for Fmoc-Tyr(Bzl)-OH
Carbodiimides	DIC, DCC	High	Essential to use with an additive (OxymaPure or HOAt recommended).[2]
Phosphonium Salts	PyBOP, PyAOP	Low to Moderate	Good choice, especially PyAOP which incorporates HOAt.[4]
Aminium/Uronium Salts	HBTU, HATU, HCTU, COMU	Low	Excellent choice, particularly HATU and COMU, for their high efficiency and low racemization potential. [4][6]

Step 2: Assess the Base Used for Activation

The base is a key contributor to racemization.

Recommendations:

- Avoid strong, non-hindered bases like triethylamine (TEA) or diisopropylethylamine (DIPEA) if racemization is a problem.
- Switch to a weaker or more sterically hindered base.

Table 2: Impact of Common Bases on Racemization

Base	Abbreviation	Basicity	Steric Hindrance	Impact on Racemization
N,N-Diisopropylethylamine	DIPEA	Strong	High	Can promote racemization, especially with sensitive residues.[7]
N-Methylmorpholine	NMM	Moderate	Moderate	A better choice than DIPEA for minimizing racemization.[1]
sym-Collidine	Weak	High	Recommended for couplings with a high risk of racemization.[4]	

Step 3: Optimize Reaction Conditions

Fine-tuning the reaction parameters can significantly reduce racemization.

Recommendations:

- **Minimize Pre-activation Time:** The activated Fmoc-Tyr(Bzl)-OH is most susceptible to racemization. Keep the pre-activation time to a minimum (e.g., 1-5 minutes) before adding the activated amino acid to the resin.[2] In-situ activation (adding the coupling reagent directly to the mixture of the amino acid and resin) can also be beneficial.
- **Lower the Temperature:** If possible, perform the coupling at a lower temperature (e.g., 0°C or room temperature). Avoid elevated temperatures unless necessary for difficult couplings, as higher temperatures accelerate racemization.
- **Solvent Choice:** While DMF and NMP are standard solvents, their polarity can sometimes favor racemization. For problematic cases, exploring alternative solvents could be considered, though this is a less common initial troubleshooting step.

Visualizing the Problem and Solution

Diagram 1: Mechanism of Racemization during Activation

Mechanism of Racemization via Enolization

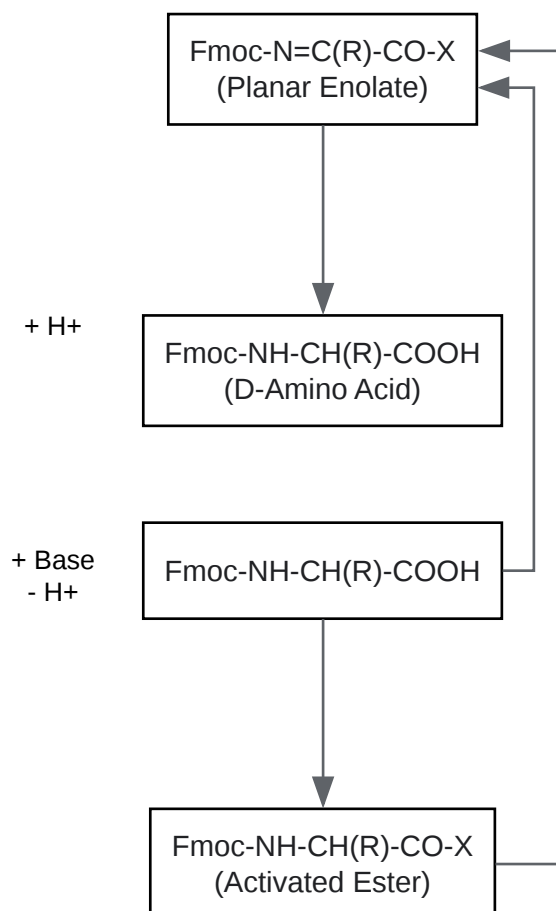

[Click to download full resolution via product page](#)

Caption: Mechanism of racemization via enolization.

Diagram 2: Troubleshooting Workflow for Racemization

Troubleshooting Workflow for High Racemization

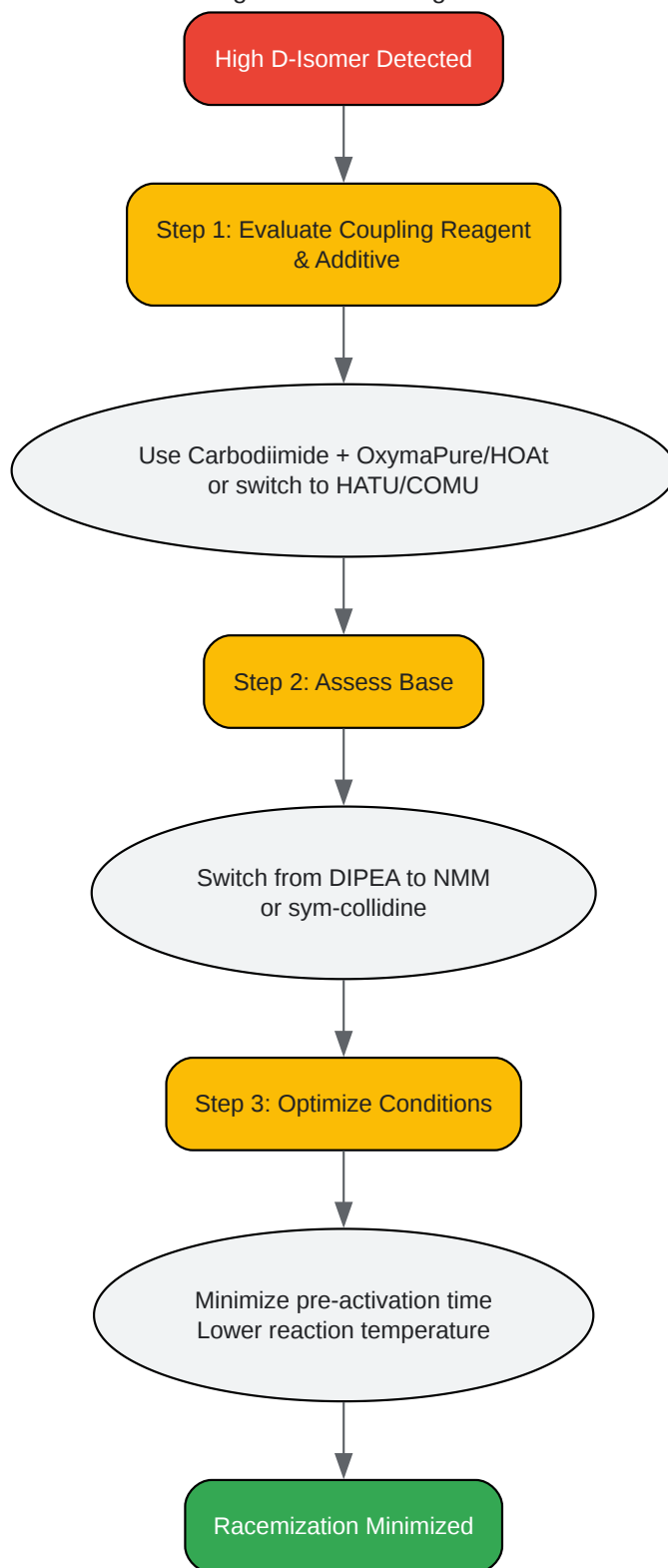

[Click to download full resolution via product page](#)

Caption: Troubleshooting workflow for minimizing racemization.

Experimental Protocols

Protocol 1: Low-Racemization Coupling of Fmoc-Tyr(Bzl)-OH using DIC/OxymaPure

This protocol is recommended for standard solid-phase peptide synthesis (SPPS) on a pre-loaded resin.

- **Resin Swelling:** Swell the resin (e.g., Rink Amide resin with the N-terminal Fmoc group removed) in high-purity N,N-dimethylformamide (DMF) for at least 30 minutes.
- **Amino Acid and Additive Preparation:** In a separate reaction vessel, dissolve Fmoc-Tyr(Bzl)-OH (3 equivalents relative to resin loading) and OxymaPure (3 equivalents) in DMF.
- **Activation:** Add N,N'-diisopropylcarbodiimide (DIC) (3 equivalents) to the amino acid/additive solution.
- **Pre-activation:** Allow the mixture to pre-activate for a short period, typically 2-5 minutes, at room temperature.^[2]
- **Coupling:** Drain the DMF from the swollen resin and immediately add the activated Fmoc-Tyr(Bzl)-OH solution. Agitate the mixture at room temperature for 1-2 hours.
- **Washing:** Drain the coupling solution and wash the resin thoroughly with DMF (3 times) and then dichloromethane (DCM) (3 times) to remove any unreacted reagents and byproducts.
- **Confirmation:** Perform a qualitative test (e.g., Kaiser test) to ensure the coupling reaction has gone to completion. If the test is positive (indicating free amines), a second coupling may be necessary.

Protocol 2: Analysis of Racemization by Chiral HPLC

This protocol outlines a general method for determining the extent of racemization.

- **Peptide Cleavage:** After synthesis, cleave a small sample of the peptide from the resin using a standard cleavage cocktail (e.g., 95% TFA, 2.5% water, 2.5% triisopropylsilane).
- **Sample Preparation:** Precipitate the crude peptide in cold diethyl ether, centrifuge to pellet the peptide, and dry the pellet. Dissolve the crude peptide in a suitable solvent for HPLC

analysis (e.g., a mixture of water and acetonitrile).

- HPLC Analysis:
 - Column: Utilize a chiral stationary phase column suitable for separating peptide diastereomers.
 - Mobile Phase: A typical mobile phase consists of a gradient of acetonitrile in water containing 0.1% trifluoroacetic acid (TFA). The exact gradient will need to be optimized for the specific peptide.
 - Detection: Monitor the eluting peptide at a suitable wavelength, typically 220 nm or 280 nm (due to the tyrosine residue).
- Quantification: The D- and L-diastereomers of the peptide should elute as separate peaks. The percentage of racemization can be calculated by integrating the peak areas: % Racemization = $[\text{Area of D-isomer peak} / (\text{Area of D-isomer peak} + \text{Area of L-isomer peak})] \times 100$

Need Custom Synthesis?

BenchChem offers custom synthesis for rare earth carbides and specific isotopic labeling.

Email: info@benchchem.com or [Request Quote Online](#).

References

- 1. benchchem.com [benchchem.com]
- 2. benchchem.com [benchchem.com]
- 3. peptide.com [peptide.com]
- 4. bachem.com [bachem.com]
- 5. Side reactions in peptide synthesis. VI. A reexamination of the benzyl group in the protection of the side chains of tyrosine and aspartic acid - PubMed [pubmed.ncbi.nlm.nih.gov]
- 6. benchchem.com [benchchem.com]
- 7. chempep.com [chempep.com]

- To cite this document: BenchChem. [Preventing racemization of Fmoc-Tyr(Bzl)-OH during activation]. BenchChem, [2025]. [Online PDF]. Available at: [<https://www.benchchem.com/product/b557360#preventing-racemization-of-fmoc-tyr-bzl-oh-during-activation>]

Disclaimer & Data Validity:

The information provided in this document is for Research Use Only (RUO) and is strictly not intended for diagnostic or therapeutic procedures. While BenchChem strives to provide accurate protocols, we make no warranties, express or implied, regarding the fitness of this product for every specific experimental setup.

Technical Support: The protocols provided are for reference purposes. Unsure if this reagent suits your experiment? [[Contact our Ph.D. Support Team for a compatibility check](#)]

Need Industrial/Bulk Grade? [Request Custom Synthesis Quote](#)

BenchChem

Our mission is to be the trusted global source of essential and advanced chemicals, empowering scientists and researchers to drive progress in science and industry.

Contact

Address: 3281 E Guasti Rd
Ontario, CA 91761, United States
Phone: (601) 213-4426
Email: info@benchchem.com