

Preventing degradation of LX2761 in storage

Author: BenchChem Technical Support Team. **Date:** December 2025

Compound of Interest

Compound Name: LX2761

Cat. No.: B10832737

[Get Quote](#)

Technical Support Center: LX2761

This technical support center provides guidance on the proper storage and handling of **LX2761** to prevent its degradation. The following information is based on general knowledge of small molecule stability and best practices in a laboratory setting.

Frequently Asked Questions (FAQs)

Q1: What are the recommended storage conditions for **LX2761**?

For optimal stability, it is recommended to store **LX2761** as a solid powder in a tightly sealed container at -20°C for long-term storage (up to 3 years).[1] For short-term storage (up to 2 years), 4°C is acceptable.[1] Once reconstituted in a solvent, it is advisable to aliquot the solution and store it at -20°C or below for up to one month to minimize freeze-thaw cycles.[1]

Q2: How should **LX2761** be handled upon receipt?

LX2761 is shipped at room temperature, as it is considered stable for the duration of shipping.[1] Upon receipt, it is crucial to transfer the product to the recommended long-term storage conditions as soon as possible. Before opening the vial, it is good practice to centrifuge it to ensure all the powder is collected at the bottom.[1]

Q3: My experiment is not working as expected. Could **LX2761** have degraded?

Unexpected experimental results can be due to a variety of factors, including the stability of the reagents. If you suspect **LX2761** degradation, consider the following:

- **Storage Conditions:** Was the compound stored as recommended?
- **Handling:** Was the compound properly handled to avoid contamination and excessive exposure to environmental factors?
- **Solvent Stability:** Is the solvent used for reconstitution appropriate and was the solution stored correctly?

If you suspect degradation, it is recommended to use a fresh vial of **LX2761** to repeat the experiment.

Q4: What are the common factors that can cause the degradation of **LX2761**?

Several environmental factors can affect the stability of small molecules like **LX2761**:

- **Temperature:** High temperatures can accelerate chemical degradation.
- **Light:** Exposure to UV or fluorescent light can cause photodegradation of light-sensitive compounds.
- **Humidity:** Moisture can lead to hydrolysis of susceptible chemical bonds.
- **pH:** The stability of a compound can be pH-dependent, with acidic or basic conditions potentially catalyzing degradation.
- **Oxidation:** Exposure to air can lead to oxidative degradation.

Troubleshooting Guide

If you observe inconsistent results or suspect degradation of **LX2761**, this guide can help you troubleshoot the issue.

Issue: Loss of Compound Activity

Potential Cause	Troubleshooting Steps
Improper Storage	- Verify the storage temperature of both the solid compound and any prepared solutions.- Ensure the container is tightly sealed to prevent exposure to moisture and air.
Light Exposure	- Store LX2761 in a light-protecting container or in the dark.
Contamination	- Use sterile techniques when preparing solutions.- Use fresh, high-purity solvents.
Multiple Freeze-Thaw Cycles	- Aliquot stock solutions into single-use volumes to avoid repeated freezing and thawing.
Incorrect Solvent	- Ensure the solvent used is compatible with LX2761 and does not promote degradation.

Experimental Protocols

Forced Degradation Study Protocol

Forced degradation studies are essential to identify potential degradation products and pathways. This information is crucial for developing stability-indicating analytical methods.

Objective: To investigate the stability of **LX2761** under various stress conditions.

Materials:

- **LX2761**
- Hydrochloric acid (HCl)
- Sodium hydroxide (NaOH)
- Hydrogen peroxide (H₂O₂)
- High-performance liquid chromatography (HPLC) system with a UV detector

- pH meter
- Photostability chamber
- Oven

Methodology:

- Preparation of Stock Solution: Prepare a stock solution of **LX2761** in a suitable solvent (e.g., DMSO, methanol).
- Stress Conditions:
 - Acid Hydrolysis: Treat the stock solution with 0.1 N HCl at 60°C for 24 hours.
 - Base Hydrolysis: Treat the stock solution with 0.1 N NaOH at 60°C for 24 hours.
 - Oxidative Degradation: Treat the stock solution with 3% H₂O₂ at room temperature for 24 hours.
 - Thermal Degradation: Expose the solid compound and the stock solution to 60°C for 48 hours.
 - Photolytic Degradation: Expose the solid compound and the stock solution to light in a photostability chamber according to ICH Q1B guidelines.
- Sample Analysis:
 - At specified time points, withdraw samples from each stress condition.
 - Neutralize the acidic and basic samples.
 - Analyze all samples by a validated stability-indicating HPLC method to determine the percentage of degradation and identify any degradation products.

Data Presentation

Table 1: Hypothetical Degradation of **LX2761** under Forced Conditions

Stress Condition	Duration (hours)	Temperature	% Degradation (Hypothetical)	Number of Degradants (Hypothetical)
0.1 N HCl	24	60°C	15	2
0.1 N NaOH	24	60°C	25	3
3% H ₂ O ₂	24	Room Temp	10	1
Heat (Solid)	48	60°C	5	1
Heat (Solution)	48	60°C	8	1
Light	-	Photostability Chamber	12	2

Visualizations

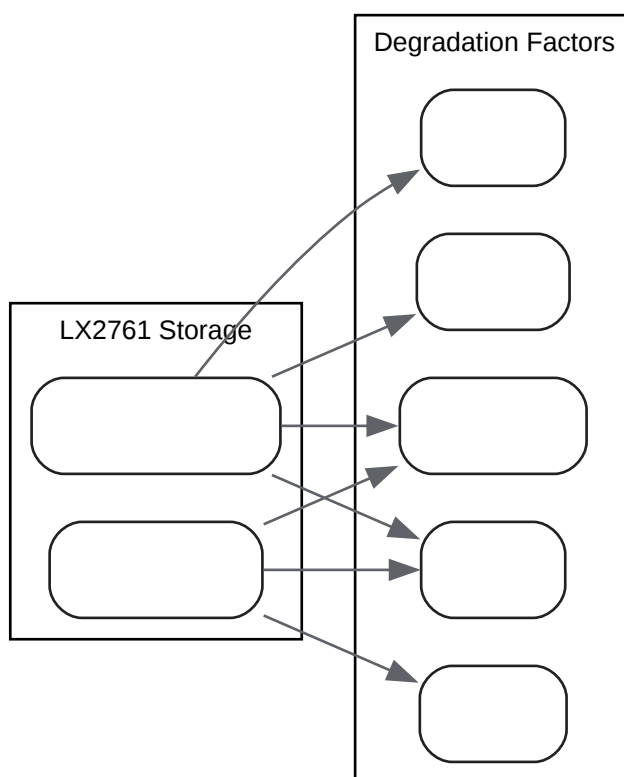

[Click to download full resolution via product page](#)

Caption: Factors contributing to the degradation of **LX2761**.

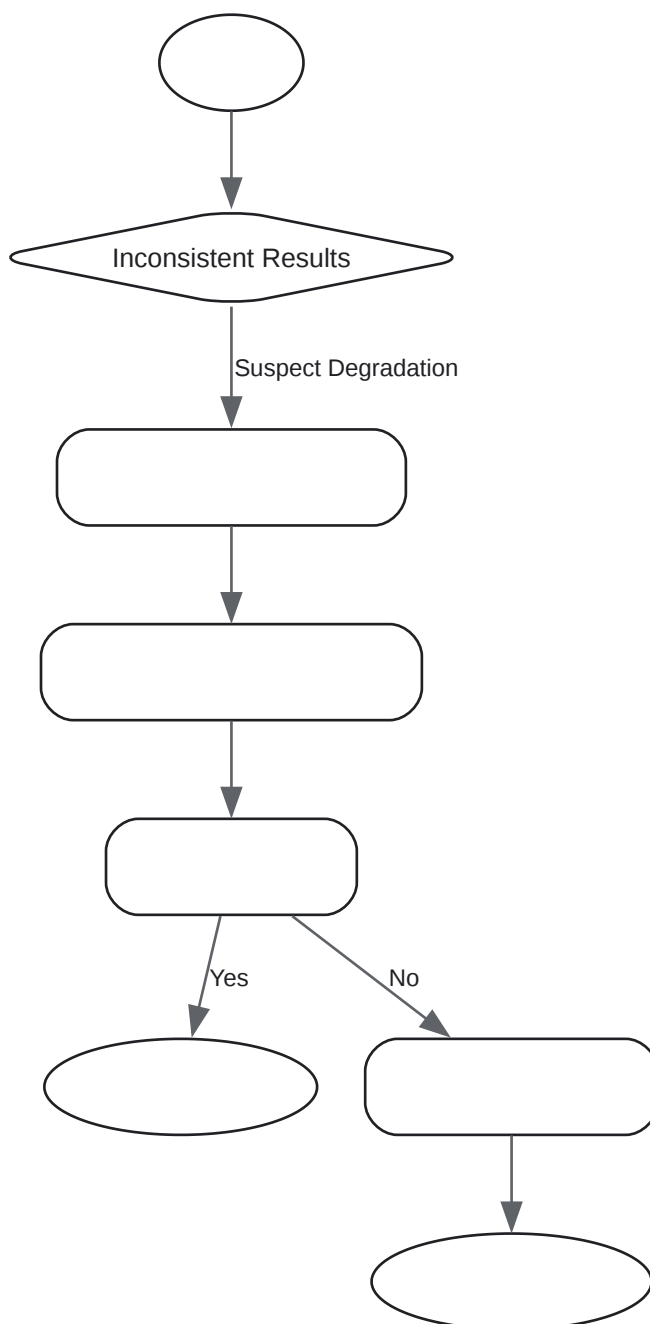

[Click to download full resolution via product page](#)

Caption: Troubleshooting workflow for suspected **LX2761** degradation.

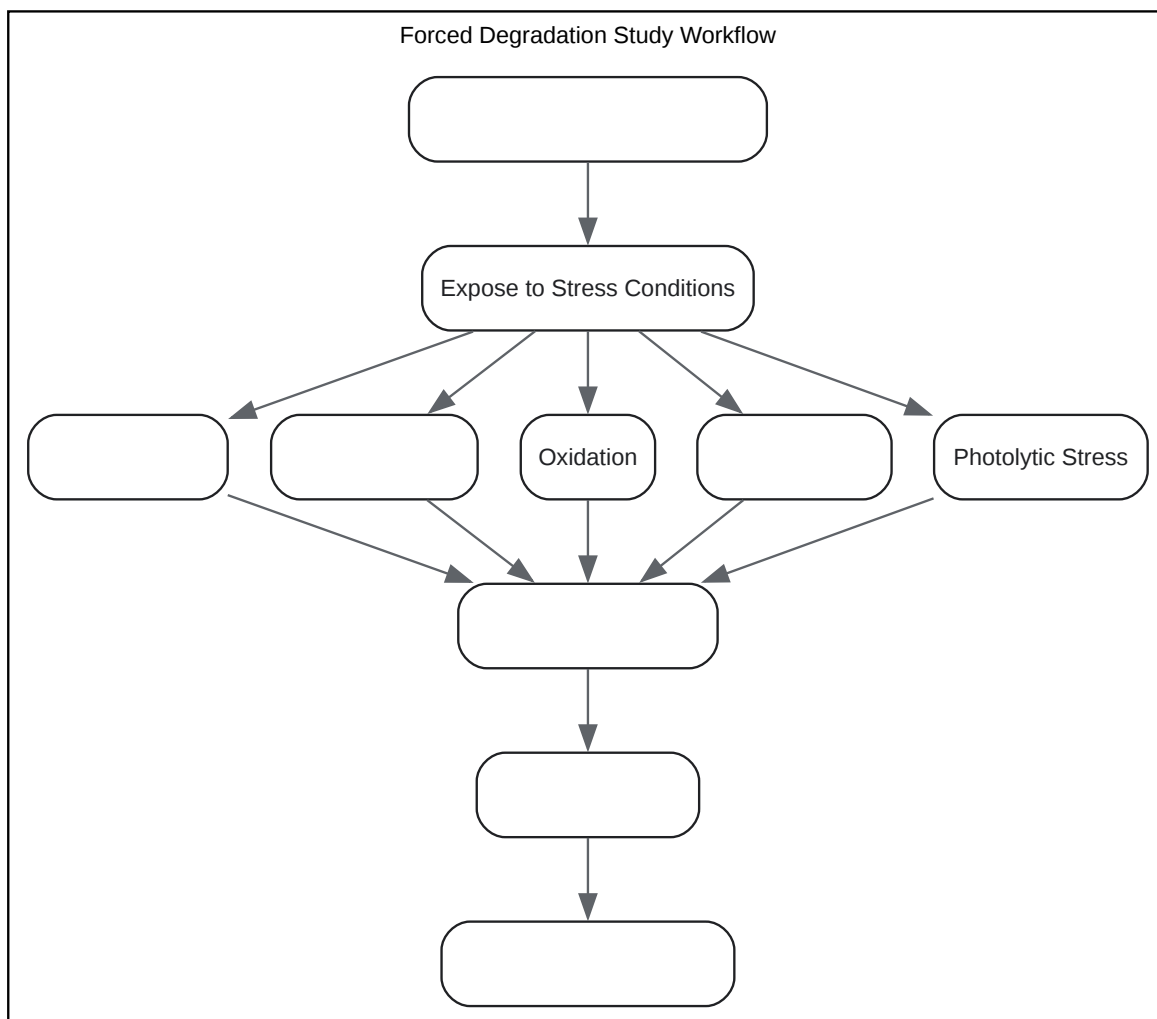

[Click to download full resolution via product page](#)

Caption: Experimental workflow for a forced degradation study of **LX2761**.

Need Custom Synthesis?

BenchChem offers custom synthesis for rare earth carbides and specific isotopic labeling.

Email: info@benchchem.com or [Request Quote Online](#).

References

- 1. [captivatebio.com](https://www.captivatebio.com) [[captivatebio.com](https://www.captivatebio.com)]
- To cite this document: BenchChem. [Preventing degradation of LX2761 in storage]. BenchChem, [2025]. [Online PDF]. Available at: [<https://www.benchchem.com/product/b10832737#preventing-degradation-of-lx2761-in-storage>]

Disclaimer & Data Validity:

The information provided in this document is for Research Use Only (RUO) and is strictly not intended for diagnostic or therapeutic procedures. While BenchChem strives to provide accurate protocols, we make no warranties, express or implied, regarding the fitness of this product for every specific experimental setup.

Technical Support: The protocols provided are for reference purposes. Unsure if this reagent suits your experiment? [[Contact our Ph.D. Support Team for a compatibility check](#)]

Need Industrial/Bulk Grade? [Request Custom Synthesis Quote](#)

BenchChem

Our mission is to be the trusted global source of essential and advanced chemicals, empowering scientists and researchers to drive progress in science and industry.

Contact

Address: 3281 E Guasti Rd

Ontario, CA 91761, United States

Phone: (601) 213-4426

Email: info@benchchem.com