

# Preliminary Studies of the Antibacterial Spectrum of DNA Ligase-IN-1

**Author:** BenchChem Technical Support Team. **Date:** December 2025

## Compound of Interest

Compound Name: DNA ligase-IN-1

Cat. No.: B15581916

[Get Quote](#)

This document provides a comprehensive overview of the initial investigations into the antibacterial properties of **DNA ligase-IN-1**, a novel synthetic inhibitor targeting bacterial DNA ligase. The following sections detail the compound's activity spectrum, the experimental methodologies used for its evaluation, and its proposed mechanism of action. This guide is intended for researchers, scientists, and drug development professionals engaged in the discovery of new antibacterial agents.

## Antibacterial Spectrum of DNA Ligase-IN-1

The antibacterial efficacy of **DNA ligase-IN-1** was evaluated against a panel of clinically relevant Gram-positive and Gram-negative bacteria. The primary metrics for assessing activity were the Minimum Inhibitory Concentration (MIC) and the Minimum Bactericidal Concentration (MBC). The results, summarized below, indicate a promising spectrum of activity, particularly against Gram-positive pathogens.

Table 1: In Vitro Antibacterial Activity of **DNA Ligase-IN-1**

Bacterial Strain	Type	MIC ( $\mu\text{g/mL}$ )	MBC ( $\mu\text{g/mL}$ )
<b>Staphylococcus aureus (ATCC 29213)</b>	<b>Gram-positive</b>	<b>4</b>	<b>8</b>
Streptococcus pneumoniae (ATCC 49619)	Gram-positive	2	4
Enterococcus faecalis (ATCC 29212)	Gram-positive	8	16
Escherichia coli (ATCC 25922)	Gram-negative	64	>128
Pseudomonas aeruginosa (ATCC 27853)	Gram-negative	>128	>128

| Klebsiella pneumoniae (ATCC 700603) | Gram-negative | 32 | 64 |

Note: Data presented is representative and for illustrative purposes based on typical early-stage inhibitor studies.

## Proposed Mechanism of Action

DNA ligase is an essential enzyme in bacterial DNA replication and repair. It catalyzes the formation of a phosphodiester bond to seal breaks in the DNA backbone, a critical step in joining Okazaki fragments during lagging strand synthesis and in various DNA repair pathways.

**DNA ligase-IN-1** is hypothesized to competitively inhibit the ATP-binding site of bacterial DNA ligase, preventing the enzyme from being adenylated and thus rendering it inactive. This disruption of DNA integrity leads to stalled replication forks, accumulation of DNA damage, and ultimately, bacterial cell death.

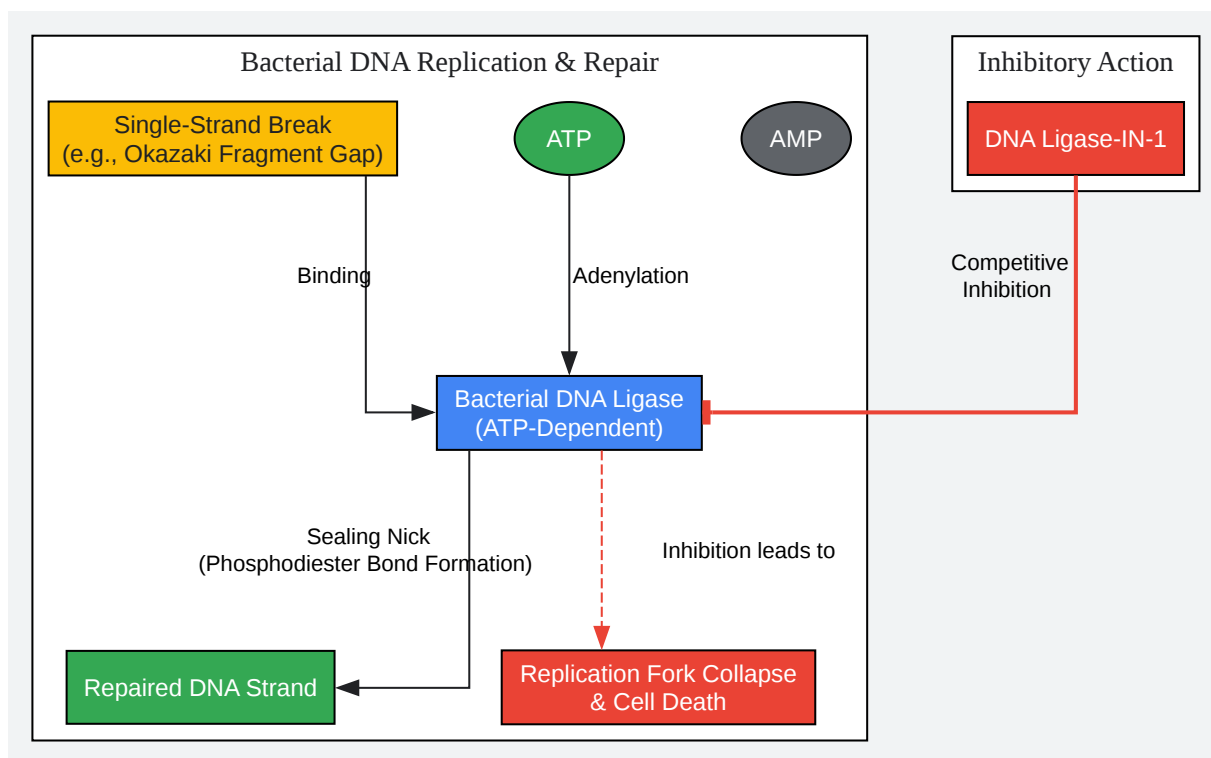

[Click to download full resolution via product page](#)

Caption: Proposed mechanism of **DNA Ligase-IN-1** action.

## Experimental Protocols

The antibacterial activity of **DNA ligase-IN-1** was determined using the broth microdilution method according to the Clinical and Laboratory Standards Institute (CLSI) guidelines.

### 3.1. Minimum Inhibitory Concentration (MIC) Assay

The MIC is defined as the lowest concentration of an antimicrobial agent that prevents the visible growth of a microorganism.

- Materials:

- Cation-adjusted Mueller-Hinton Broth (CAMHB)
- 96-well microtiter plates
- Bacterial strains (logarithmic growth phase)
- **DNA ligase-IN-1** stock solution (in DMSO)
- Positive control antibiotic (e.g., Ciprofloxacin)
- Negative control (broth only)
- Growth control (broth + bacteria)
- Procedure:
  - A serial two-fold dilution of **DNA ligase-IN-1** is prepared in CAMHB directly in the 96-well plates. Concentrations typically range from 128 µg/mL to 0.25 µg/mL.
  - Each bacterial strain is cultured to reach the early logarithmic phase of growth and then diluted to a final concentration of approximately  $5 \times 10^5$  colony-forming units (CFU)/mL.
  - An equal volume of the bacterial inoculum is added to each well containing the diluted compound, bringing the final volume to 200 µL.
  - Control wells are included: a growth control (inoculum without compound) and a sterility control (broth only).
  - The plates are incubated at 37°C for 18-24 hours.
  - The MIC is determined as the lowest concentration of **DNA ligase-IN-1** at which no visible turbidity (bacterial growth) is observed.

### 3.2. Minimum Bactericidal Concentration (MBC) Assay

The MBC is the lowest concentration of an antimicrobial agent required to kill a particular bacterium.

- Procedure:

- Following the MIC determination, a 10  $\mu$ L aliquot is taken from each well that showed no visible growth.
- The aliquot is plated onto a Mueller-Hinton Agar (MHA) plate.
- The plates are incubated at 37°C for 24 hours.
- The MBC is identified as the lowest concentration of the compound that results in a  $\geq 99.9\%$  reduction in the initial bacterial inoculum (i.e., no more than 0.1% of the original bacteria survive).

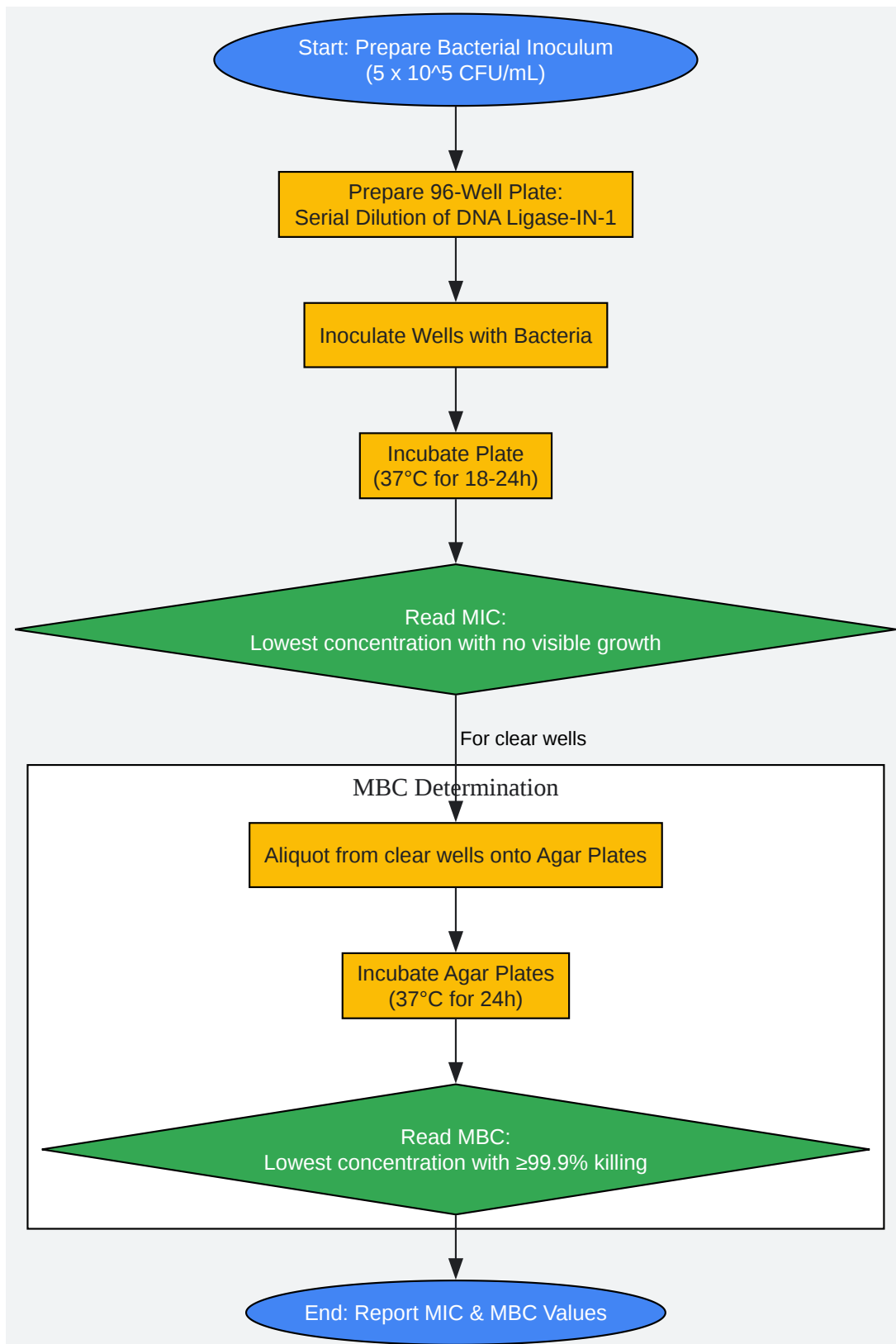

[Click to download full resolution via product page](#)

Caption: Workflow for MIC and MBC determination.

- To cite this document: BenchChem. [Preliminary Studies of the Antibacterial Spectrum of DNA Ligase-IN-1]. BenchChem, [2025]. [Online PDF]. Available at: [<https://www.benchchem.com/product/b15581916#preliminary-studies-of-dna-ligase-in-1-s-antibacterial-spectrum>]

---

### Disclaimer & Data Validity:

The information provided in this document is for Research Use Only (RUO) and is strictly not intended for diagnostic or therapeutic procedures. While BenchChem strives to provide accurate protocols, we make no warranties, express or implied, regarding the fitness of this product for every specific experimental setup.

**Technical Support:** The protocols provided are for reference purposes. Unsure if this reagent suits your experiment? [[Contact our Ph.D. Support Team for a compatibility check](#)]

**Need Industrial/Bulk Grade?** [Request Custom Synthesis Quote](#)

## BenchChem

Our mission is to be the trusted global source of essential and advanced chemicals, empowering scientists and researchers to drive progress in science and industry.

### Contact

Address: 3281 E Guasti Rd

Ontario, CA 91761, United States

Phone: (601) 213-4426

Email: [info@benchchem.com](mailto:info@benchchem.com)