

Potential Therapeutic Targets of Angelol K: A Technical Guide

Author: BenchChem Technical Support Team. **Date:** December 2025

Compound of Interest

Compound Name: *Angelol K*

Cat. No.: *B1640547*

[Get Quote](#)

Executive Summary

Angelol K, also known as ingenol-3-angelate or PEP005, is a diterpene ester extracted from the plant *Euphorbia peplus*. It has demonstrated significant potential as a therapeutic agent, primarily in the context of oncology. The core mechanism of **Angelol K** revolves around the modulation of Protein Kinase C (PKC) isoforms, which triggers a cascade of downstream signaling events culminating in cancer cell death. This technical guide provides an in-depth overview of the therapeutic targets of **Angelol K**, detailing its mechanism of action, affected signaling pathways, and the experimental validation of these effects. The information is intended for researchers, scientists, and drug development professionals.

Primary Therapeutic Target: Protein Kinase C (PKC)

The principal molecular target of **Angelol K** is the family of Protein Kinase C (PKC) isoenzymes. **Angelol K** exhibits a dual modulatory effect, primarily activating the novel PKC δ isoform while inhibiting the classical PKC α isoform.[1] This differential regulation is a key determinant of its anti-cancer activity.

- **PKC δ Activation:** Activation of PKC δ is a critical event in the pro-apoptotic effects of **Angelol K**. Upon treatment, PKC δ translocates from the cytoplasm to the nucleus and other cellular membranes, initiating downstream signaling cascades that promote apoptosis.[2]
- **PKC α Inhibition:** Conversely, the inhibition of PKC α by **Angelol K** contributes to its anti-proliferative effects. PKC α is often implicated in cell survival and proliferation pathways.[1]

This selective modulation of PKC isoforms distinguishes **Angelol K** from pan-PKC activators and contributes to its therapeutic window.

Downstream Signaling Pathways

The modulation of PKC by **Angelol K** instigates a dual signaling cascade that converges to induce cancer cell death. These pathways are the activation of the Mitogen-Activated Protein Kinase (MAPK) pathway and the inhibition of the Phosphatidylinositol 3-Kinase (PI3K)/AKT pathway.^{[2][3]}

Activation of the MAPK Pathway

Angelol K treatment leads to the phosphorylation and subsequent activation of several key components of the MAPK signaling cascade. This pro-apoptotic pathway activation includes:

- Raf-1: An upstream kinase in the MAPK cascade.
- ERK1/2: Extracellular signal-regulated kinases 1 and 2.
- JNK: c-Jun N-terminal kinase.
- p38 MAPK: p38 mitogen-activated protein kinase.

The activation of these kinases contributes to the induction of apoptosis and cell cycle arrest.^[2]

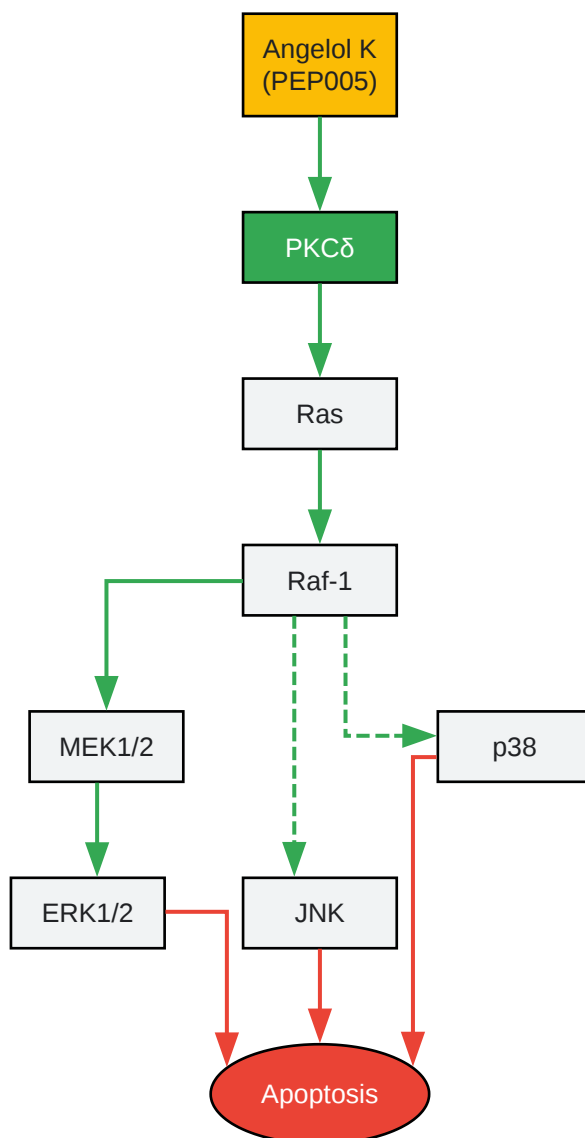

[Click to download full resolution via product page](#)

Figure 1: Angelol K-induced activation of the MAPK signaling pathway.

Inhibition of the PI3K/AKT Pathway

Concurrently with MAPK activation, **Angelol K** inhibits the pro-survival PI3K/AKT signaling pathway. This is achieved through:

- Reduced AKT Phosphorylation: **Angelol K** treatment leads to a decrease in the active, phosphorylated form of AKT.

- Increased PTEN Phosphorylation: The tumor suppressor PTEN, a negative regulator of the PI3K pathway, is phosphorylated and activated.

The inhibition of this pathway removes a critical survival signal for cancer cells, thereby sensitizing them to apoptosis.[2]

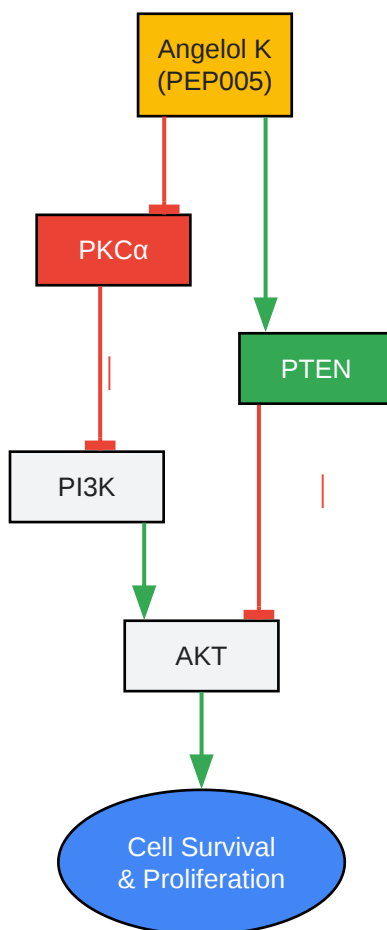

[Click to download full resolution via product page](#)

Figure 2: Angelol K-induced inhibition of the PI3K/AKT signaling pathway.

Quantitative Data: In Vitro Efficacy

The anti-proliferative activity of **Angelol K** (PEP005) has been quantified in various cancer cell lines. The half-maximal inhibitory concentration (IC₅₀) values demonstrate a range of sensitivities.

Cell Line	Cancer Type	IC50 (μM) after 48h
Colo205	Colon Cancer	0.01
MDA-MB-435	Melanoma	2.6
HCC2998	Colon Cancer	30

Table 1: IC50 values of PEP005 in various cancer cell lines. Data extracted from Serova et al., Mol Cancer Ther, 2008.[4]

Experimental Protocols

The following are detailed methodologies for key experiments used to elucidate the therapeutic targets and mechanism of action of **Angelol K**.

Western Blot Analysis for Protein Phosphorylation

This protocol is used to detect the phosphorylation status of key proteins in the PKC, MAPK, and PI3K/AKT signaling pathways following treatment with **Angelol K**.

Workflow:



[Click to download full resolution via product page](#)

Figure 3: General workflow for Western blot analysis.

Methodology:

- Cell Culture and Treatment: Plate cancer cells (e.g., Colo205) and grow to 70-80% confluency. Treat cells with desired concentrations of **Angelol K** (e.g., 0.3 μM) for various time points (e.g., 0, 15, 30, 60 minutes).
- Lysis: Wash cells with ice-cold PBS and lyse with RIPA buffer supplemented with protease and phosphatase inhibitors.

- **Protein Quantification:** Determine protein concentration using a BCA protein assay kit.
- **SDS-PAGE and Transfer:** Separate equal amounts of protein (20-30 μg) on a 10% SDS-polyacrylamide gel and transfer to a PVDF membrane.
- **Blocking and Antibody Incubation:** Block the membrane with 5% non-fat dry milk or BSA in TBST for 1 hour at room temperature. Incubate with primary antibodies overnight at 4°C. Recommended primary antibodies include: p-PKC δ , PKC δ , p-PKC α , PKC α , p-Raf-1, p-ERK1/2, ERK1/2, p-JNK, JNK, p-p38, p38, p-AKT, AKT, p-PTEN, PTEN, and β -actin (as a loading control).
- **Detection:** Wash the membrane with TBST and incubate with HRP-conjugated secondary antibodies for 1 hour at room temperature. Visualize protein bands using an enhanced chemiluminescence (ECL) detection system.

Apoptosis Assay via Annexin V/Propidium Iodide Staining

This flow cytometry-based assay distinguishes between viable, early apoptotic, late apoptotic, and necrotic cells.

Methodology:

- **Cell Treatment:** Treat cells with **Angelol K** (e.g., 1 μM) for specified durations (e.g., 6, 12, 24 hours).
- **Cell Harvesting:** Collect both adherent and floating cells. Wash with cold PBS.
- **Staining:** Resuspend cells in 1X Annexin V binding buffer. Add FITC-conjugated Annexin V and propidium iodide (PI) to the cell suspension.
- **Incubation:** Incubate the cells for 15 minutes at room temperature in the dark.
- **Flow Cytometry:** Analyze the stained cells by flow cytometry. FITC-Annexin V positive and PI negative cells are considered early apoptotic, while cells positive for both stains are late apoptotic or necrotic.

Cell Cycle Analysis via Propidium Iodide Staining

This method quantifies the distribution of cells in different phases of the cell cycle (G0/G1, S, G2/M).

Methodology:

- Cell Treatment: Treat cells with **Angelol K** (e.g., 0.3 μ M) for various time points (e.g., 1, 5, 12, 24, 48 hours).
- Fixation: Harvest cells, wash with PBS, and fix in ice-cold 70% ethanol overnight at -20°C.
- Staining: Wash the fixed cells with PBS and resuspend in a staining solution containing propidium iodide and RNase A.
- Incubation: Incubate for 30 minutes at room temperature in the dark.
- Flow Cytometry: Analyze the DNA content of the cells using a flow cytometer. The intensity of PI fluorescence is proportional to the amount of DNA.

Conclusion

Angelol K (PEP005) presents a compelling profile as a potential anti-cancer therapeutic. Its primary mechanism of action, the dual modulation of PKC δ and PKC α , leads to a favorable downstream signaling cascade for cancer cell elimination: the activation of the pro-apoptotic MAPK pathway and the inhibition of the pro-survival PI3K/AKT pathway. The quantitative data and established experimental protocols provide a solid foundation for further preclinical and clinical investigation into the therapeutic applications of **Angelol K**. This guide summarizes the core technical information necessary for researchers and drug developers to understand and explore the potential of this promising compound.

Need Custom Synthesis?

BenchChem offers custom synthesis for rare earth carbides and specific isotopic labeling.

Email: info@benchchem.com or [Request Quote Online](#).

References

- 1. Antiproliferative activity of PEP005, a novel ingenol angelate that modulates PKC functions, alone and in combination with cytotoxic agents in human colon cancer cells - PubMed [pubmed.ncbi.nlm.nih.gov]
- 2. researchgate.net [researchgate.net]
- 3. Effects of protein kinase C modulation by PEP005, a novel ingenol angelate, on mitogen-activated protein kinase and phosphatidylinositol 3-kinase signaling in cancer cells - PubMed [pubmed.ncbi.nlm.nih.gov]
- 4. aacrjournals.org [aacrjournals.org]
- To cite this document: BenchChem. [Potential Therapeutic Targets of Angelol K: A Technical Guide]. BenchChem, [2025]. [Online PDF]. Available at: [https://www.benchchem.com/product/b1640547#potential-therapeutic-targets-of-angelol-k]

Disclaimer & Data Validity:

The information provided in this document is for Research Use Only (RUO) and is strictly not intended for diagnostic or therapeutic procedures. While BenchChem strives to provide accurate protocols, we make no warranties, express or implied, regarding the fitness of this product for every specific experimental setup.

Technical Support: The protocols provided are for reference purposes. Unsure if this reagent suits your experiment? [[Contact our Ph.D. Support Team for a compatibility check](#)]

Need Industrial/Bulk Grade? [Request Custom Synthesis Quote](#)

BenchChem

Our mission is to be the trusted global source of essential and advanced chemicals, empowering scientists and researchers to drive progress in science and industry.

Contact

Address: 3281 E Guasti Rd
Ontario, CA 91761, United States
Phone: (601) 213-4426
Email: info@benchchem.com