

# Phenacetin-13C: A Technical Guide for Researchers

**Author:** BenchChem Technical Support Team. **Date:** December 2025

## Compound of Interest

Compound Name: Phenacetin-13C

Cat. No.: B1601150

[Get Quote](#)

For Researchers, Scientists, and Drug Development Professionals

## Abstract

**Phenacetin-13C** is the stable isotope-labeled counterpart of phenacetin, a once widely used analgesic and antipyretic drug. Due to its identical chemical properties to the unlabeled compound, coupled with a distinct mass shift, **Phenacetin-13C** serves as an invaluable tool in modern analytical and metabolic research. This technical guide provides an in-depth overview of **Phenacetin-13C**, including its synthesis, analytical applications as an internal standard, metabolic pathways, and relevant experimental protocols. Quantitative data are summarized in structured tables, and key experimental workflows and metabolic pathways are visualized using diagrams.

## Introduction

Phenacetin, or N-(4-ethoxyphenyl)acetamide, was introduced in 1887 and became a common component of analgesic mixtures for nearly a century before being withdrawn from the market in the 1980s due to its association with nephrotoxicity and carcinogenicity.[1][2] Despite its withdrawal from clinical use, phenacetin remains a critical probe substrate for studying the activity of cytochrome P450 enzymes, particularly CYP1A2.[3][4]

The use of stable isotope-labeled internal standards, such as **Phenacetin-13C**, is a cornerstone of modern quantitative analysis by mass spectrometry.[5] These standards co-elute with the analyte of interest and exhibit identical ionization efficiency, allowing for precise

and accurate quantification by correcting for variations in sample preparation and instrument response.[5] **Phenacetin-13C** is primarily utilized as an internal standard for the quantification of phenacetin and its metabolites in biological matrices and as a tracer to elucidate its metabolic fate.[6][7]

## Chemical and Physical Properties

The physical and chemical properties of **Phenacetin-13C** are essentially identical to those of unlabeled phenacetin, with the exception of a slight increase in molecular weight due to the incorporation of the <sup>13</sup>C isotope(s).

Property	Value	Reference
Chemical Formula	C <sub>10</sub> H <sub>13</sub> NO <sub>2</sub> (unlabeled)	[8]
IUPAC Name	N-(4-ethoxyphenyl)acetamide	[8]
Molecular Weight	179.22 g/mol (unlabeled)	[8]
Appearance	White crystalline solid	[1]
Melting Point	134-136 °C	[9]
Solubility	Sparingly soluble in water, soluble in ethanol and acetone	[1]

## Synthesis of Phenacetin-13C

A detailed, specific protocol for the synthesis of **Phenacetin-13C** is not readily available in the public domain. However, it can be synthesized by adapting established methods for unlabeled phenacetin, such as the Williamson ether synthesis, using a <sup>13</sup>C-labeled starting material. The most common approach involves the ethylation of a <sup>13</sup>C-labeled acetaminophen precursor.

## General Synthesis Scheme (Williamson Ether Synthesis)

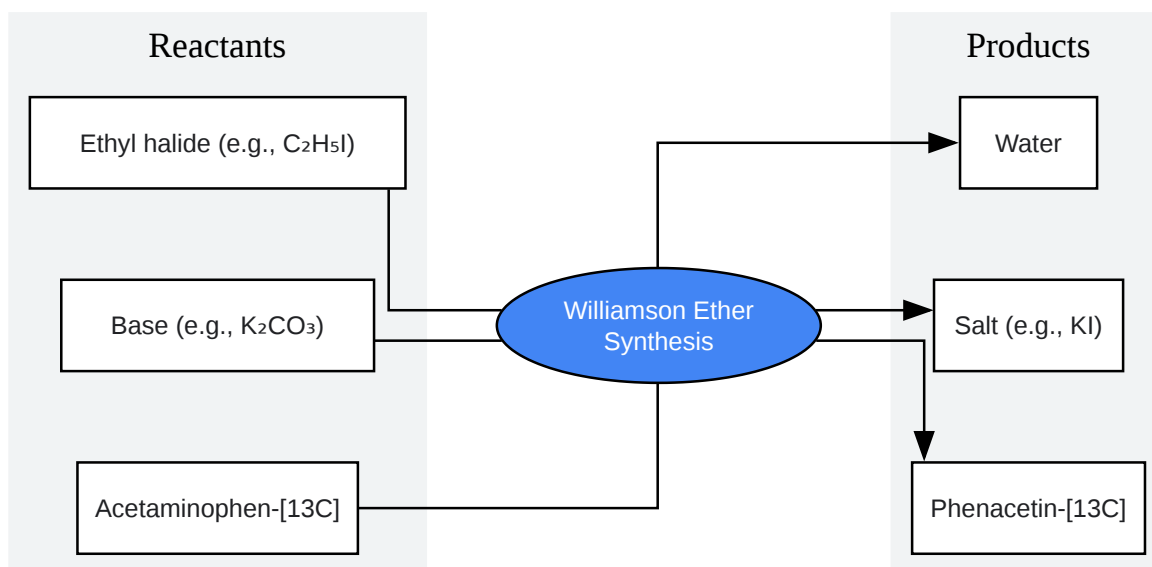

[Click to download full resolution via product page](#)

**Figure 1:** General synthesis scheme for **Phenacetin-13C**.

## Experimental Protocol (Adapted from Unlabeled Synthesis)

This protocol is adapted from the Williamson ether synthesis of unlabeled phenacetin and should be optimized for the specific <sup>13</sup>C-labeled starting material used.<sup>[10]</sup>

- **Reaction Setup:** In a round-bottom flask, dissolve <sup>13</sup>C-labeled acetaminophen in a suitable solvent such as acetone or 2-butanone.
- **Addition of Base:** Add a base, such as anhydrous potassium carbonate, to the solution. This will deprotonate the phenolic hydroxyl group of acetaminophen to form the corresponding phenoxide.
- **Addition of Ethylating Agent:** Add an ethylating agent, such as ethyl iodide or ethyl bromide, to the reaction mixture.
- **Reflux:** Heat the mixture to reflux for an appropriate amount of time (typically 1-2 hours) to allow the reaction to proceed to completion.

- **Workup:** After cooling, the reaction mixture is typically filtered to remove the inorganic salts. The filtrate is then concentrated under reduced pressure.
- **Purification:** The crude **Phenacetin-13C** is purified by recrystallization from a suitable solvent system, such as ethanol/water, to yield the final product.

## Analytical Applications

The primary application of **Phenacetin-13C** is as an internal standard in quantitative mass spectrometry-based assays for the determination of phenacetin and its metabolites in various biological matrices.<sup>[6][7]</sup>

## Use as an Internal Standard in LC-MS/MS Analysis

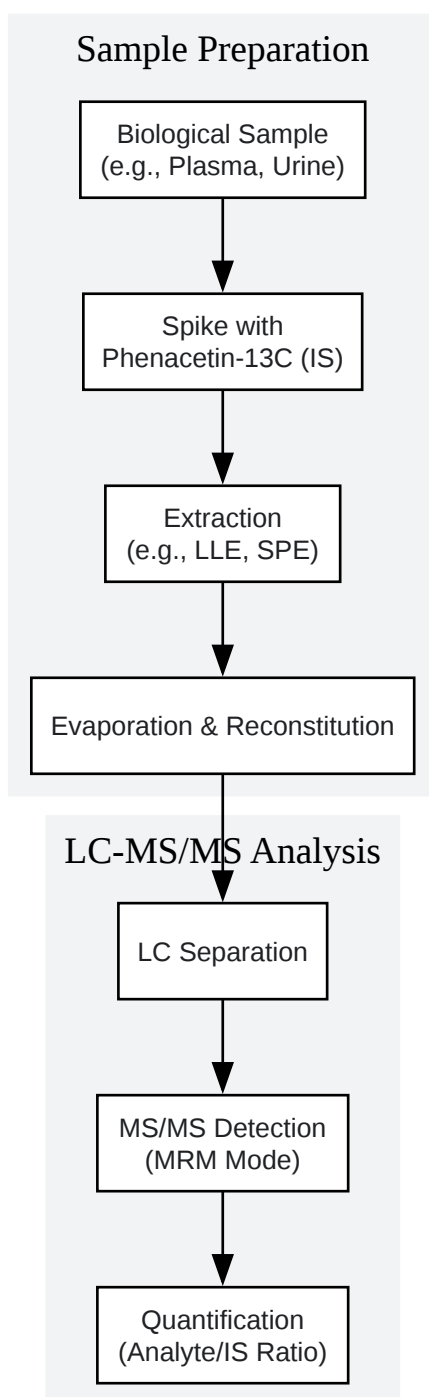

[Click to download full resolution via product page](#)

**Figure 2:** Workflow for quantitative analysis using **Phenacetin-13C**.

## Experimental Protocol: Quantification of Phenacetin in Plasma

This protocol is a generalized procedure and may require optimization based on the specific instrumentation and matrix used.[6][11]

- Sample Preparation:
  - To 100  $\mu$ L of plasma sample, add a known amount of **Phenacetin-13C** internal standard solution.
  - Perform protein precipitation by adding a solvent like acetonitrile, followed by vortexing and centrifugation.
  - Alternatively, perform liquid-liquid extraction with a suitable organic solvent (e.g., ethyl acetate) or solid-phase extraction.
  - Evaporate the supernatant/organic layer to dryness under a stream of nitrogen.
  - Reconstitute the residue in the mobile phase.
- LC-MS/MS Analysis:
  - Liquid Chromatography: Separate the analyte and internal standard on a C18 reverse-phase column using a gradient elution with a mobile phase consisting of water and acetonitrile with a modifier like formic acid.
  - Mass Spectrometry: Perform detection using a tandem mass spectrometer in positive electrospray ionization (ESI) mode. Monitor the specific precursor-to-product ion transitions for both phenacetin and **Phenacetin-13C** in Multiple Reaction Monitoring (MRM) mode.

Compound	Precursor Ion (m/z)	Product Ion (m/z)
Phenacetin	180.1	138.1
Phenacetin-13C (example with one 13C)	181.1	139.1
Acetaminophen	152.1	110.1

Note: The exact m/z values for **Phenacetin-13C** will depend on the number and position of the <sup>13</sup>C labels.

- Quantification:
  - Construct a calibration curve by plotting the peak area ratio of the analyte to the internal standard against the concentration of the analyte in the calibration standards.
  - Determine the concentration of phenacetin in the unknown samples by interpolating their peak area ratios from the calibration curve.

## Metabolism of Phenacetin

Phenacetin is extensively metabolized in the liver, primarily through O-deethylation to its major active metabolite, acetaminophen (paracetamol).[2] This reaction is predominantly catalyzed by the cytochrome P450 enzyme CYP1A2.[3]

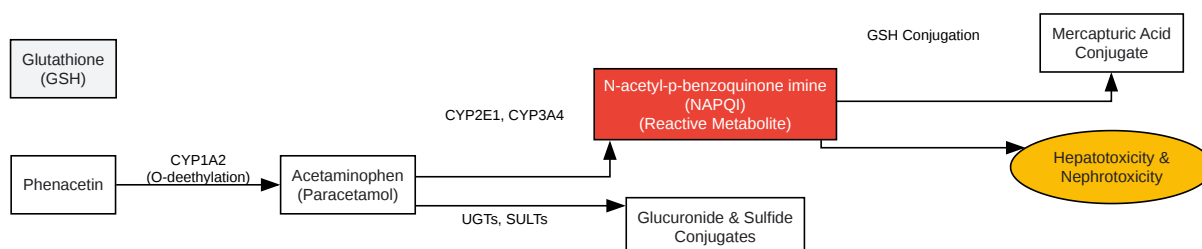

[Click to download full resolution via product page](#)

**Figure 3:** Major metabolic pathway of Phenacetin.

## Enzyme Kinetics of Phenacetin O-deethylation

The O-deethylation of phenacetin by human liver microsomes often exhibits biphasic kinetics, with a high-affinity component primarily attributed to CYP1A2 and a low-affinity component involving other CYP isoforms.[3]

Enzyme	Km ( $\mu\text{M}$ )	Vmax (nmol/hr/mg protein)	Reference
CYP1A2 (High Affinity)	17.7 - 68	14 $\pm$ 2.3	[12][13][14]
CYP2A6	4098	-	[3]
CYP2C9	566	-	[3]
CYP2C19	656	-	[3]
CYP2D6	1021	-	[3]
CYP2E1	1257	-	[3]

Note: Kinetic parameters can vary depending on the experimental conditions and the source of the enzyme.

## Experimental Protocol: In Vitro Phenacetin O-deethylation Assay

This protocol is used to determine the activity of CYP1A2 in human liver microsomes.[12][15]

- Incubation Mixture: Prepare an incubation mixture containing human liver microsomes, a NADPH-generating system (or NADPH), and buffer (e.g., potassium phosphate buffer, pH 7.4).
- Pre-incubation: Pre-incubate the mixture at 37°C for a few minutes.
- Initiation of Reaction: Initiate the reaction by adding phenacetin (the substrate).
- Incubation: Incubate the reaction at 37°C for a specified time (e.g., 15-30 minutes).
- Termination of Reaction: Stop the reaction by adding a quenching agent, such as a cold organic solvent (e.g., acetonitrile) or an acid (e.g., perchloric acid).
- Sample Processing: Centrifuge the mixture to pellet the precipitated proteins.



- Analysis: Analyze the supernatant for the formation of acetaminophen using a validated analytical method, such as LC-MS/MS.

## Conclusion

**Phenacetin-13C** is an indispensable tool for researchers in drug metabolism and pharmacokinetics. Its use as an internal standard ensures the accuracy and reliability of quantitative bioanalytical methods for phenacetin and its metabolites. Furthermore, as a metabolic tracer, it allows for the detailed investigation of the metabolic pathways of phenacetin, particularly the activity of the clinically significant enzyme CYP1A2. The experimental protocols and data presented in this guide provide a solid foundation for the effective application of **Phenacetin-13C** in a research setting.

### Need Custom Synthesis?

BenchChem offers custom synthesis for rare earth carbides and specific isotopic labeling.

Email: [info@benchchem.com](mailto:info@benchchem.com) or [Request Quote Online](#).

## References

1. NMR Spectrum of Phenacetin | Thermo Fisher Scientific - US [[thermofisher.com](https://thermofisher.com)]
2. Phenacetin: pharmacokinetics, mechanism of action and clinical applications\_Chemicalbook [[chemicalbook.com](https://chemicalbook.com)]
3. Human cytochromes P450 mediating phenacetin O-deethylation in vitro: validation of the high affinity component as an index of CYP1A2 activity - PubMed [[pubmed.ncbi.nlm.nih.gov](https://pubmed.ncbi.nlm.nih.gov)]
4. Inhibition of Baicalin on Metabolism of Phenacetin, a Probe of CYP1A2, in Human Liver Microsomes and in Rats - PMC [[pmc.ncbi.nlm.nih.gov](https://pmc.ncbi.nlm.nih.gov)]
5. Utilizing 13C-Labeled Internal Standards to Advance the Analysis of Heparan Sulfate - PMC [[pmc.ncbi.nlm.nih.gov](https://pmc.ncbi.nlm.nih.gov)]
6. Quantitative determination of phenacetin and its metabolite acetaminophen by GLC-chemical ionization mass spectrometry - PubMed [[pubmed.ncbi.nlm.nih.gov](https://pubmed.ncbi.nlm.nih.gov)]
7. [medchemexpress.com](https://medchemexpress.com) [[medchemexpress.com](https://medchemexpress.com)]
8. Phenacetin | C10H13NO2 | CID 4754 - PubChem [[pubchem.ncbi.nlm.nih.gov](https://pubchem.ncbi.nlm.nih.gov)]
9. [m.youtube.com](https://m.youtube.com) [[m.youtube.com](https://m.youtube.com)]

- 10. Synthesis Preparation of Phenacetin from Acetaminophen | Hunter College CUNY - Edubirdie [edubirdie.com]
- 11. researchgate.net [researchgate.net]
- 12. [O-ethyl 14C]phenacetin O-deethylase activity in human liver microsomes - PubMed [pubmed.ncbi.nlm.nih.gov]
- 13. Phenacetin O-deethylation by human liver microsomes in vitro: inhibition by chemical probes, SSRI antidepressants, nefazodone and venlafaxine - PubMed [pubmed.ncbi.nlm.nih.gov]
- 14. Phenacetin O-deethylation by human liver microsomes: kinetics and propranolol inhibition - PubMed [pubmed.ncbi.nlm.nih.gov]
- 15. KEY RESIDUES CONTROLLING PHENACETIN METABOLISM BY HUMAN CYTOCHROME P450 2A ENZYMES† - PMC [pmc.ncbi.nlm.nih.gov]
- To cite this document: BenchChem. [Phenacetin-13C: A Technical Guide for Researchers]. BenchChem, [2025]. [Online PDF]. Available at: [https://www.benchchem.com/product/b1601150#what-is-phenacetin-13c]

---

### Disclaimer & Data Validity:

The information provided in this document is for Research Use Only (RUO) and is strictly not intended for diagnostic or therapeutic procedures. While BenchChem strives to provide accurate protocols, we make no warranties, express or implied, regarding the fitness of this product for every specific experimental setup.

**Technical Support:** The protocols provided are for reference purposes. Unsure if this reagent suits your experiment? [[Contact our Ph.D. Support Team for a compatibility check](#)]

**Need Industrial/Bulk Grade?** [Request Custom Synthesis Quote](#)

## BenchChem

Our mission is to be the trusted global source of essential and advanced chemicals, empowering scientists and researchers to drive progress in science and industry.

### Contact

Address: 3281 E Guasti Rd

Ontario, CA 91761, United States

Phone: (601) 213-4426

Email: [info@benchchem.com](mailto:info@benchchem.com)

