

# Personal protective equipment for handling Robotnikinin

**Author:** BenchChem Technical Support Team. **Date:** December 2025

## Compound of Interest

Compound Name: Robotnikinin

Cat. No.: B1679495

[Get Quote](#)

## Essential Safety and Handling Guide for Robotnikinin

For Researchers, Scientists, and Drug Development Professionals

This document provides crucial safety and logistical information for the handling and disposal of **Robotnikinin** (CAS No. 1132653-79-2), a small molecule inhibitor of the Sonic Hedgehog (Shh) signaling pathway. Adherence to these guidelines is essential to ensure personal safety and minimize environmental contamination in the laboratory.

## Hazard Identification and Personal Protective Equipment (PPE)

**Robotnikinin** is a potent bioactive compound. While specific toxicity data is limited, it should be handled with care as a potentially hazardous substance. The following Personal Protective Equipment (PPE) is mandatory when handling **Robotnikinin** in solid or solution form.

## Recommended Personal Protective Equipment

A comprehensive list of recommended PPE for handling **Robotnikinin** is provided below.

PPE Category	Specification
Eye Protection	Chemical safety goggles or a face shield.
Hand Protection	Nitrile gloves. Change gloves immediately if contaminated.
Body Protection	A laboratory coat must be worn at all times. For procedures with a risk of splashing, a chemical-resistant apron is recommended.
Respiratory Protection	For handling the solid compound or when aerosolization is possible, a NIOSH-approved respirator is required. Work in a certified chemical fume hood.

## Hazard Pictograms and Statements

While a specific GHS classification for **Robotnikinin** is not universally established, based on its nature as a potent small molecule inhibitor, it is prudent to handle it with the assumption that it may possess hazards warranting the following precautions.

Pictogram	Signal Word	Hazard Statement
!	Warning	May cause skin irritation. May cause serious eye irritation. May cause respiratory irritation.

## Experimental Protocols: Safe Handling and Disposal

Strict adherence to the following protocols is necessary to ensure the safe handling and disposal of **Robotnikinin**.

### Step-by-Step Handling Procedure

- Preparation: Before handling **Robotnikinin**, ensure that the designated work area, typically a certified chemical fume hood, is clean and uncluttered. Have all necessary equipment and

reagents readily available, including waste containers.

- Donning PPE: Put on all required PPE as listed in Table 1.1. Ensure gloves are intact and provide a good fit.
- Weighing Solid Compound:
  - Perform all weighing operations within a chemical fume hood or a balance enclosure.
  - Use a dedicated, clean spatula and weighing paper.
  - Carefully transfer the desired amount of **Robotnikinin** to a tared container.
  - Clean the spatula and the weighing area with a suitable solvent (e.g., 70% ethanol) and dispose of the cleaning materials as hazardous waste.
- Preparing Solutions:
  - Add the solvent to the solid **Robotnikinin** slowly to avoid splashing.
  - Cap the container and mix by vortexing or gentle agitation until the solid is fully dissolved. **Robotnikinin** is soluble in DMSO and ethanol.
- Use in Experiments:
  - Clearly label all tubes and containers with the compound name, concentration, and date.
  - When transferring solutions, use appropriate pipettes and tips.
  - Avoid creating aerosols.
- Post-Experiment:
  - Decontaminate all surfaces and equipment that came into contact with **Robotnikinin** using an appropriate solvent.
  - Dispose of all contaminated materials as outlined in the disposal plan.
- Doffing PPE:

- Remove gloves first, peeling them off from the cuff to the fingertips to avoid touching the outer surface.
- Remove the lab coat, folding it inward.
- Remove eye protection.
- Wash hands thoroughly with soap and water.

## Disposal Plan

All waste materials contaminated with **Robotnikinin** must be treated as hazardous chemical waste.

Waste Type	Disposal Procedure
Unused Solid Robotnikinin	Dispose of in its original container or a clearly labeled, sealed waste container for hazardous solids.
Solutions of Robotnikinin	Collect in a dedicated, sealed, and clearly labeled hazardous liquid waste container. Do not mix with other incompatible waste streams.
Contaminated Labware (e.g., pipette tips, tubes)	Collect in a designated, sealed hazardous waste bag or container.
Contaminated PPE (e.g., gloves, disposable lab coats)	Dispose of in a designated hazardous waste container immediately after use.

Follow all institutional and local regulations for the disposal of hazardous chemical waste.

## Workflow and Signaling Pathway Diagrams

To provide a clear visual guide, the following diagrams illustrate the safe handling workflow and the targeted signaling pathway of **Robotnikinin**.

## Safe Handling Workflow for Robotnikinin

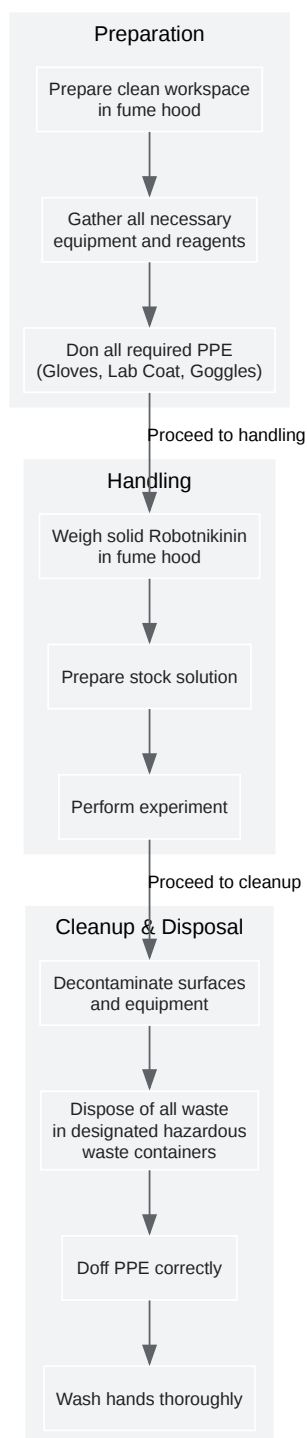

[Click to download full resolution via product page](#)

Caption: Workflow for the safe handling of **Robotnikinin** from preparation to disposal.

## Robotnikinin's Mechanism of Action

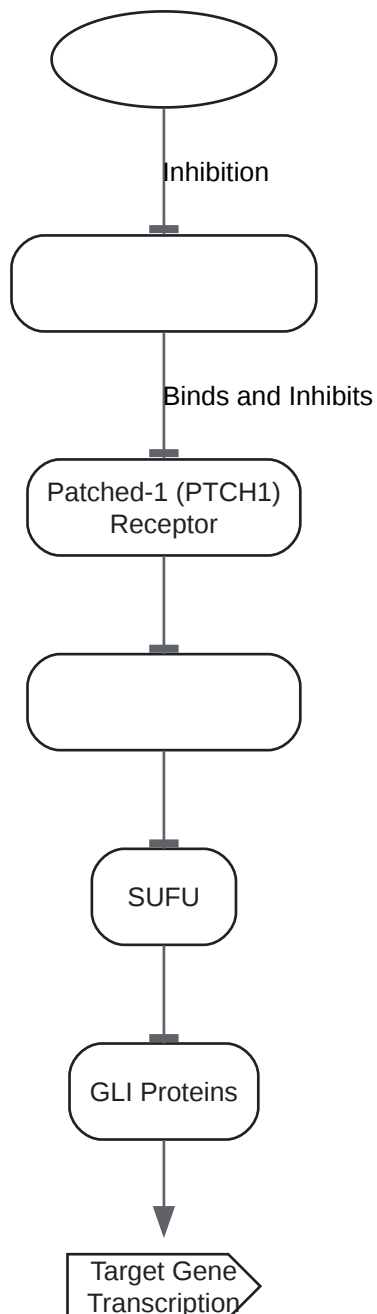

[Click to download full resolution via product page](#)

Caption: **Robotnikinin** directly binds to and inhibits the Sonic Hedgehog (Shh) ligand.

- To cite this document: BenchChem. [Personal protective equipment for handling Robotnikinin]. BenchChem, [2025]. [Online PDF]. Available at: [<https://www.benchchem.com/product/b1679495#personal-protective-equipment-for-handling-robotnikinin>]

---

### Disclaimer & Data Validity:

The information provided in this document is for Research Use Only (RUO) and is strictly not intended for diagnostic or therapeutic procedures. While BenchChem strives to provide accurate protocols, we make no warranties, express or implied, regarding the fitness of this product for every specific experimental setup.

**Technical Support:** The protocols provided are for reference purposes. Unsure if this reagent suits your experiment? [[Contact our Ph.D. Support Team for a compatibility check](#)]

**Need Industrial/Bulk Grade?** [Request Custom Synthesis Quote](#)

## BenchChem

Our mission is to be the trusted global source of essential and advanced chemicals, empowering scientists and researchers to drive progress in science and industry.

### Contact

Address: 3281 E Guasti Rd  
Ontario, CA 91761, United States  
Phone: (601) 213-4426  
Email: [info@benchchem.com](mailto:info@benchchem.com)