

PH-002 Versus Other ApoE4 Modulators: A Comparative Guide for Researchers

Author: BenchChem Technical Support Team. **Date:** December 2025

Compound of Interest

Compound Name: PH-002

Cat. No.: B15616862

[Get Quote](#)

For drug development professionals, researchers, and scientists, this guide provides an objective comparison of **PH-002**, a small molecule structure corrector of Apolipoprotein E4 (ApoE4), with other emerging ApoE4 modulators. This document synthesizes available preclinical and clinical data to evaluate their performance and therapeutic potential in the context of Alzheimer's disease and other ApoE4-related pathologies.

The Apolipoprotein E4 (ApoE4) allele is the most significant genetic risk factor for late-onset Alzheimer's disease. Its protein product, ApoE4, adopts a pathological conformation due to a single amino acid change, leading to a cascade of neurotoxic events, including increased amyloid-beta (A β) aggregation, tau hyperphosphorylation, and neuronal dysfunction. Modulating ApoE4's structure and function presents a promising therapeutic strategy. This guide focuses on a direct comparison of **PH-002** with other ApoE4 modulators, including other structure correctors, lipidation enhancers, and ApoE mimetic peptides.

Mechanism of Action: A Structural and Functional Overview

ApoE4 modulators can be broadly categorized based on their mechanism of action. Understanding these differences is crucial for evaluating their therapeutic potential and potential for combination therapies.

- ApoE4 Structure Correctors: These small molecules, such as **PH-002** and GIND-25, are designed to directly bind to the ApoE4 protein and correct its misfolded structure.[1][2] This

structural correction is intended to restore its function to be more like the neutral ApoE3 isoform, thereby mitigating its pathological effects.[3]

- ApoE Lipidation Enhancers: This class of drugs, including bexarotene and CS-6253, aims to increase the lipidation of ApoE4.[4][5] Proper lipidation is crucial for ApoE's function in cholesterol transport and A β clearance. By enhancing lipidation, these modulators aim to improve ApoE4's physiological functions.
- ApoE Mimetic Peptides: These are small peptides, such as CN-105 and Ac-hE18A-NH₂, that are designed to mimic the beneficial functions of the ApoE protein, such as its anti-inflammatory and neuroprotective properties, without being isoform-specific.[6][7]

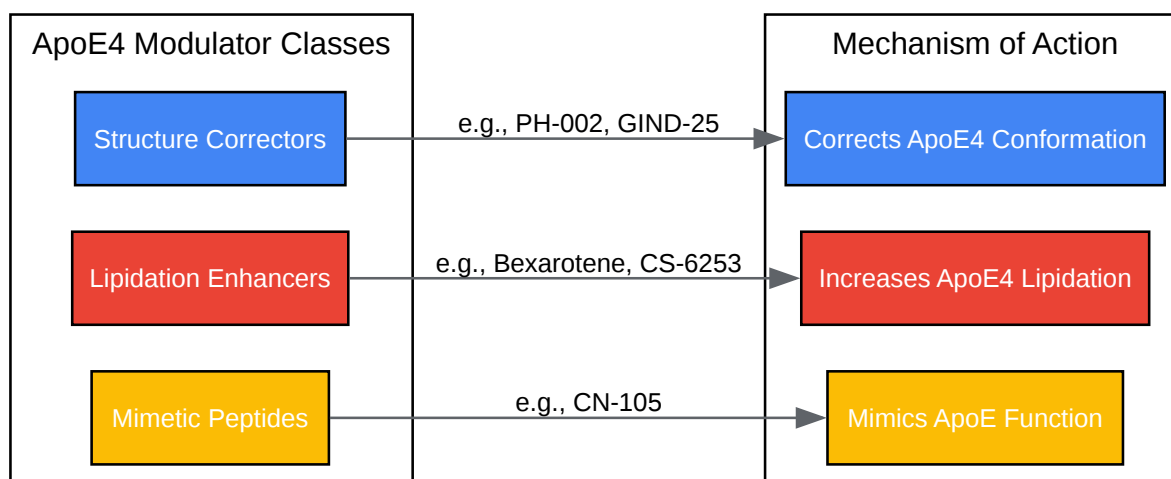

[Click to download full resolution via product page](#)

Fig. 1: Classification of ApoE4 Modulators

Preclinical Data Summary: A Head-to-Head Comparison

The following tables summarize the available preclinical data for **PH-002** and other selected ApoE4 modulators across key experimental endpoints relevant to Alzheimer's disease pathology. It is important to note that the data is compiled from various studies and direct head-to-head comparisons in the same experimental systems are limited.

Table 1: ApoE4 Structure Correctors - PH-002 vs. GIND-25

Parameter	PH-002	GIND-25	Reference(s)
Mechanism	ApoE4 Structure Corrector	ApoE4 Structure Corrector	[1][2]
IC50 (FRET Assay)	116 nM	Not Reported	
Effective Concentration (ApoE4 Trafficking Rescue)	100 nM	1 μ M	[8]
Effect on Neurite Outgrowth	Rescued ApoE4-induced impairment	Not Reported	[8]
Effect on Dendritic Spine Density	Increased to ApoE3 levels	Not Reported	[8]
Effect on Mitochondrial Function	Restores mitochondrial function	Not Reported	

Table 2: Comparison of PH-002 with Other Classes of ApoE4 Modulators

Modulator (Class)	Key Preclinical Findings	Reference(s)
PH-002 (Structure Corrector)	Corrects ApoE4 structure, rescues trafficking defects, restores neurite outgrowth and dendritic spine density, improves mitochondrial function.	[8]
Bexarotene (Lipidation Enhancer)	Increases ApoE lipidation, reduces soluble A β levels, and reverses cognitive deficits in mouse models. Clinical trial results were mixed, with some benefit in ApoE4 non-carriers.	[4][9][10]
CS-6253 (Lipidation Enhancer)	Increases lipidation of ApoE4, reverses A β 42 accumulation and tau hyperphosphorylation, and reverses synaptic and cognitive deficits in ApoE4-targeted replacement mice.	[2][5][11]
CN-105 (ApoE Mimetic Peptide)	Reduces brain inflammation, improves brain pathology, and enhances learning and memory in a mouse model of Alzheimer's disease with the ApoE4 allele.	[4][6][12][13][14][15]
Ac-hE18A-NH2 (ApoE Mimetic Peptide)	Reduces plasma cholesterol and possesses anti-inflammatory properties. Shown to decrease A β levels in vitro and in vivo.	[5][7][16][17][18][19]

Experimental Protocols

Detailed methodologies are crucial for the interpretation and replication of experimental findings. Below are descriptions of key experimental protocols used to evaluate the efficacy of ApoE4 modulators.

Förster Resonance Energy Transfer (FRET) Assay for ApoE4 Domain Interaction

This cell-based assay is used to screen for compounds that can disrupt the interaction between the N-terminal and C-terminal domains of the ApoE4 protein, a key feature of its pathological conformation.

Principle: FRET is a mechanism describing energy transfer between two light-sensitive molecules (chromophores). A donor chromophore, initially in its electronic excited state, may transfer energy to an acceptor chromophore through non-radiative dipole-dipole coupling. The efficiency of this energy transfer is inversely proportional to the sixth power of the distance between donor and acceptor, making FRET extremely sensitive to small changes in distance.

Protocol Outline:

- **Constructs:** Neuronal cells are transfected with a construct encoding ApoE4 fused to a FRET pair, such as a cyan fluorescent protein (CFP) at the N-terminus and a yellow fluorescent protein (YFP) at the C-terminus.
- **Compound Treatment:** Cells are treated with the test compound (e.g., **PH-002**) at various concentrations.
- **Imaging:** Cells are imaged using a fluorescence microscope equipped for FRET imaging. The emission of YFP is measured upon excitation of CFP.
- **Data Analysis:** The FRET efficiency is calculated as the ratio of YFP emission to CFP emission. A decrease in FRET efficiency indicates that the compound has disrupted the domain interaction, increasing the distance between the N- and C-termini.

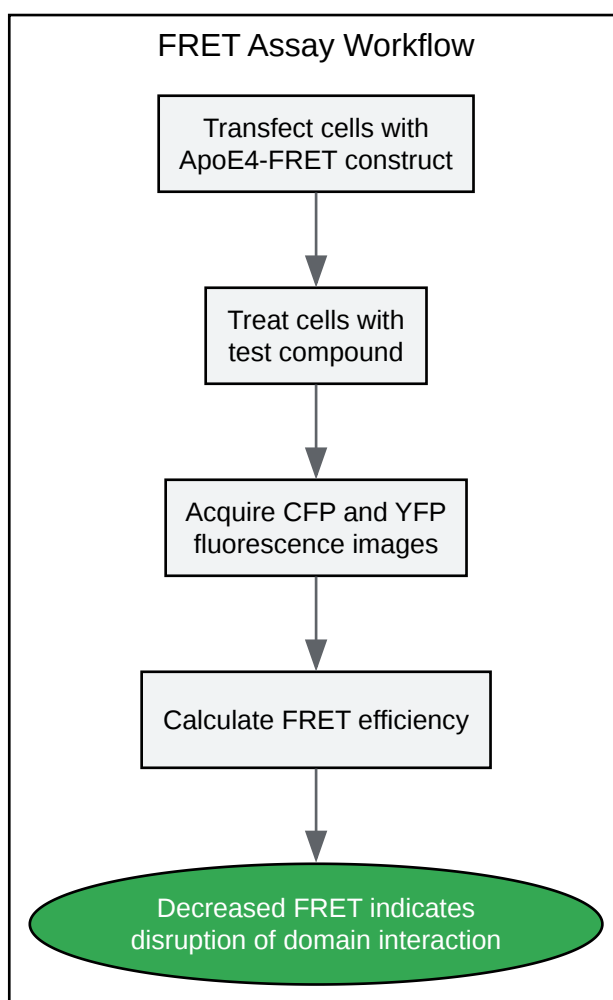

[Click to download full resolution via product page](#)

Fig. 2: FRET Assay Workflow

Fluorescence Recovery After Photobleaching (FRAP) for ApoE4 Trafficking

FRAP is a microscopy technique used to study the dynamics of molecular mobility, in this case, the trafficking of ApoE4 within the secretory pathway of live cells.

Principle: A specific region of interest within a cell expressing a fluorescently tagged protein (e.g., GFP-ApoE4) is irreversibly photobleached using a high-intensity laser. The subsequent recovery of fluorescence in the bleached area is monitored over time. The rate of recovery provides information about the mobility of the fluorescently tagged protein.

Protocol Outline:

- **Cell Culture:** Neuronal cells are cultured on glass-bottom dishes and transfected with a plasmid encoding GFP-ApoE4.
- **Compound Treatment:** Cells are treated with the ApoE4 modulator (e.g., **PH-002**) or a vehicle control.
- **Image Acquisition:** Live-cell imaging is performed using a confocal microscope. A pre-bleach image is acquired.
- **Photobleaching:** A defined region of interest (e.g., within the endoplasmic reticulum or Golgi apparatus) is photobleached with a high-intensity laser.
- **Post-Bleach Imaging:** A time-lapse series of images is acquired to monitor the recovery of fluorescence in the bleached region.
- **Data Analysis:** The fluorescence intensity in the bleached region is measured over time and normalized to the pre-bleach intensity. The rate of fluorescence recovery and the mobile fraction of the protein are calculated. An increased rate of recovery indicates improved trafficking of ApoE4.[\[20\]](#)[\[21\]](#)[\[22\]](#)[\[23\]](#)[\[24\]](#)

Dendritic Spine Density and Morphology Analysis

This method is used to assess the effects of ApoE4 modulators on the structure of dendritic spines, which are the primary sites of excitatory synapses in the brain and are known to be affected in Alzheimer's disease.

Principle: Golgi-Cox staining is a classic histological technique that sparsely labels a small percentage of neurons in their entirety, allowing for the detailed visualization of dendritic branches and spines.

Protocol Outline:

- **Tissue Preparation:** Brain tissue from animal models is processed using a Golgi-Cox staining kit. This involves immersion in a solution containing potassium dichromate and mercuric chloride, followed by a silver nitrate solution.[\[1\]](#)[\[6\]](#)[\[25\]](#)[\[26\]](#)[\[27\]](#)

- **Sectioning:** The stained brain tissue is sectioned using a vibratome or cryostat.
- **Imaging:** Sections are imaged under a high-magnification microscope. Z-stack images of dendrites from specific neuronal populations are acquired.
- **Image Analysis:** The number of dendritic spines per unit length of dendrite is quantified to determine spine density. The morphology of the spines (e.g., length, head width) can also be analyzed using image analysis software. An increase in spine density or a shift towards a more mature spine morphology is indicative of a neuroprotective effect.

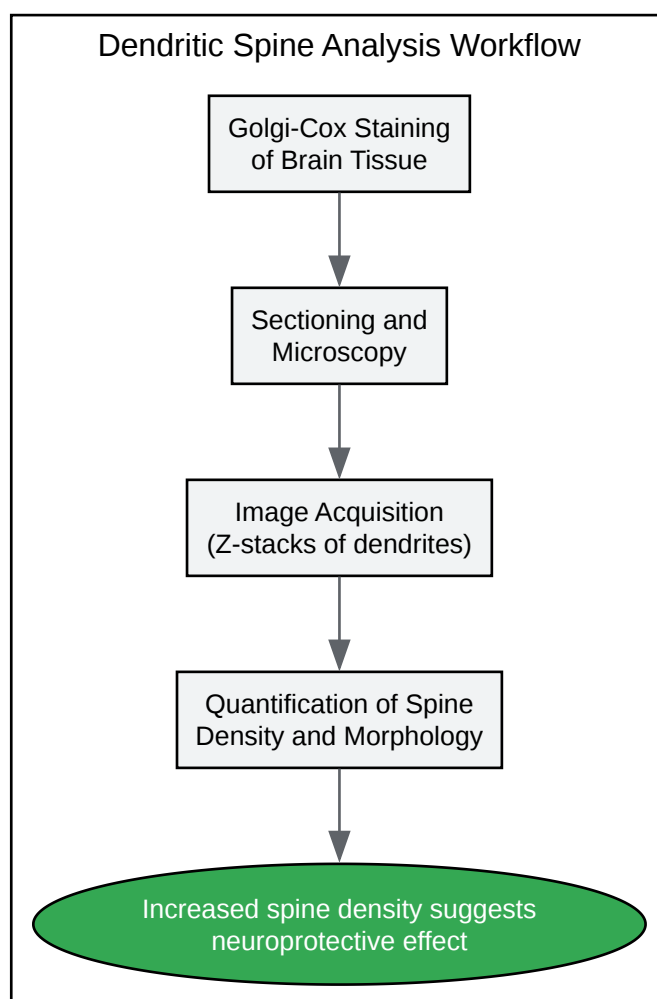

[Click to download full resolution via product page](#)

Fig. 3: Dendritic Spine Analysis Workflow

Conclusion

PH-002, as a small molecule ApoE4 structure corrector, represents a targeted therapeutic approach to address the fundamental protein misfolding that contributes to ApoE4's pathological effects. Preclinical data suggests that **PH-002** is a potent modulator of ApoE4, demonstrating efficacy in cellular models at nanomolar concentrations. When compared to other ApoE4 modulators, such as lipidation enhancers and mimetic peptides, **PH-002** offers a distinct mechanism of action that directly addresses the root cause of ApoE4's gain of toxic function.

While lipidation enhancers like bexarotene and CS-6253 have shown promise in preclinical models, their clinical translation has been met with mixed results or is still in early stages. ApoE mimetic peptides offer a broader, function-mimicking approach but may not specifically target the pathological conformation of ApoE4.

Further head-to-head preclinical studies in standardized animal models are warranted to provide a more definitive comparison of these different therapeutic strategies. The continued development and investigation of **PH-002** and other ApoE4 modulators hold significant promise for the development of novel, disease-modifying therapies for Alzheimer's disease and other ApoE4-associated conditions. The detailed experimental protocols provided in this guide are intended to facilitate the rigorous evaluation of these and future ApoE4-targeted therapeutics.

Need Custom Synthesis?

BenchChem offers custom synthesis for rare earth carbides and specific isotopic labeling.

Email: info@benchchem.com or [Request Quote Online](#).

References

- 1. Rapid Golgi Stain for Dendritic Spine Visualization in Hippocampus and Prefrontal Cortex [jove.com]
- 2. APOE and Alzheimer's Disease: Advances in Genetics, Pathophysiology, and Therapeutic Approaches - PMC [pmc.ncbi.nlm.nih.gov]
- 3. Effect of the ABCA1 agonist CS-6253 on amyloid- β and lipoprotein metabolism in cynomolgus monkeys - PMC [pmc.ncbi.nlm.nih.gov]

- 4. curealz.org [curealz.org]
- 5. Novel fatty acyl apoE mimetic peptides have increased potency to reduce plasma cholesterol in mice and macaques - PMC [pmc.ncbi.nlm.nih.gov]
- 6. Rapid Golgi Analysis Method for Efficient and Unbiased Classification of Dendritic Spines | PLOS One [journals.plos.org]
- 7. Frontiers | Apolipoprotein Mimetic Peptides: A New Approach for the Treatment of Asthma [frontiersin.org]
- 8. Structure-dependent Impairment of Intracellular Apolipoprotein E4 Trafficking and Its Detrimental Effects Are Rescued by Small-molecule Structure Correctors - PMC [pmc.ncbi.nlm.nih.gov]
- 9. alzforum.org [alzforum.org]
- 10. Reversal of apoE4-driven brain pathology and behavioral deficits by bexarotene - PubMed [pubmed.ncbi.nlm.nih.gov]
- 11. alzforum.org [alzforum.org]
- 12. Apolipoprotein E mimetic peptide CN-105 improves outcome in a murine model of SAH - PMC [pmc.ncbi.nlm.nih.gov]
- 13. Can an ApoE Mimetic Peptide Reduce Rates of Secondary Brain Injury? | Duke Health Referring Physicians [physicians.dukehealth.org]
- 14. researchgate.net [researchgate.net]
- 15. Scholars@Duke publication: Apolipoprotein E mimetic peptide CN-105 improves outcome in a murine model of SAH. [scholars.duke.edu]
- 16. Apolipoprotein E mimetic is more effective than apolipoprotein A-I mimetic in reducing lesion formation in older female apo E null mice - PMC [pmc.ncbi.nlm.nih.gov]
- 17. researchgate.net [researchgate.net]
- 18. Ac-hE-18A-NH₂, a novel dual-domain apolipoprotein mimetic peptide, inhibits apoptosis in macrophages by promoting cholesterol efflux - PubMed [pubmed.ncbi.nlm.nih.gov]
- 19. ApoE mimetic peptide decreases A β production in vitro and in vivo - PMC [pmc.ncbi.nlm.nih.gov]
- 20. ibidi.com [ibidi.com]
- 21. researchgate.net [researchgate.net]
- 22. Fluorescence recovery after photobleaching (FRAP) [protocols.io]

- 23. Fluorescence Recovery After Photobleaching (FRAP) of Fluorescence Tagged Proteins in Dendritic Spines of Cultured Hippocampal Neurons - PMC [pmc.ncbi.nlm.nih.gov]
- 24. Fluorescence recovery after photobleaching - Wikipedia [en.wikipedia.org]
- 25. Rapid Golgi Analysis Method for Efficient and Unbiased Classification of Dendritic Spines - PMC [pmc.ncbi.nlm.nih.gov]
- 26. Methods of Dendritic Spine Detection: from Golgi to High Resolution Optical Imaging - PMC [pmc.ncbi.nlm.nih.gov]
- 27. Scholars@Duke publication: Rapid Golgi analysis method for efficient and unbiased classification of dendritic spines. [scholars.duke.edu]
- To cite this document: BenchChem. [PH-002 Versus Other ApoE4 Modulators: A Comparative Guide for Researchers]. BenchChem, [2025]. [Online PDF]. Available at: [https://www.benchchem.com/product/b15616862#ph-002-versus-other-apoe4-modulators]

Disclaimer & Data Validity:

The information provided in this document is for Research Use Only (RUO) and is strictly not intended for diagnostic or therapeutic procedures. While BenchChem strives to provide accurate protocols, we make no warranties, express or implied, regarding the fitness of this product for every specific experimental setup.

Technical Support: The protocols provided are for reference purposes. Unsure if this reagent suits your experiment? [[Contact our Ph.D. Support Team for a compatibility check](#)]

Need Industrial/Bulk Grade? [Request Custom Synthesis Quote](#)

BenchChem

Our mission is to be the trusted global source of essential and advanced chemicals, empowering scientists and researchers to drive progress in science and industry.

Contact

Address: 3281 E Guasti Rd
Ontario, CA 91761, United States
Phone: (601) 213-4426
Email: info@benchchem.com