

PF-03463275 CAS number and synonyms

Author: BenchChem Technical Support Team. **Date:** December 2025

Compound of Interest

Compound Name: PF-03463275

Cat. No.: B1461716

[Get Quote](#)

An In-depth Technical Guide to PF-03463275

This technical guide provides a comprehensive overview of **PF-03463275**, a selective inhibitor of the glycine transporter-1 (GlyT1). It is intended for researchers, scientists, and professionals in drug development, offering detailed information on its chemical properties, mechanism of action, and relevant experimental data.

Chemical Identity

Property	Value
CAS Number	1173239-39-8[1][2][3]
Synonyms	PF-3463275, PF 3463275, PF 03463275, compound 10, KB-79869[2][4]
Molecular Formula	C19H22ClFN4O[3]
Molecular Weight	376.86 g/mol [3]
Hydrochloride CAS	1173177-11-1[5]

Mechanism of Action

PF-03463275 is a centrally penetrant, orally available, selective, and competitive reversible inhibitor of the glycine transporter-1 (GlyT1)[1][5][6]. GlyT1 is a key protein responsible for the reuptake of glycine from the synaptic cleft, thereby regulating its extracellular concentration[4].

The primary mechanism of action of **PF-03463275** involves the potentiation of N-methyl-D-aspartate receptor (NMDAR) function[4]. NMDARs are critical for excitatory neurotransmission and synaptic plasticity, and their activation requires the binding of both glutamate and a co-agonist, either glycine or D-serine[7]. By inhibiting GlyT1, **PF-03463275** increases the concentration of glycine in the synapse, leading to enhanced co-agonist stimulation of NMDARs[4]. This modulation of NMDAR signaling has been investigated for its therapeutic potential in treating cognitive impairments associated with schizophrenia (CIAS)[4][8].

Quantitative Data

In Vitro Binding Affinity

Parameter	Value	Notes
Ki (GlyT1)	11.6 nM[1][5][6]	Competitive inhibitor
Ki (GlyT1)	13 nM[2]	
IC50 (GlyT2)	> 10 μM[9]	Demonstrates high selectivity for GlyT1 over GlyT2

In Vivo GlyT1 Occupancy in Schizophrenia Patients

Data from a Positron Emission Tomography (PET) study in patients with schizophrenia receiving twice-daily (BID) doses of **PF-03463275**[10][11][12].

Dose (BID)	Mean GlyT1 Occupancy
10 mg	~44%
20 mg	~61%
40 mg	~76%
60 mg	~83%

Experimental Protocols

GlyT1 Occupancy Measurement via PET Scan

This protocol was designed to determine the dose-related occupancy of GlyT1 by **PF-03463275**.

- Subjects: Healthy volunteers and patients with schizophrenia[10][11].
- Imaging Agent: 18F-MK-6577, a radioligand for PET imaging of GlyT1[10][11].
- Procedure:
 - Subjects received one of several doses of **PF-03463275** (10, 20, 40, or 60 mg) twice daily[10][11].
 - PET scans were conducted to measure the binding of 18F-MK-6577 to GlyT1 in the brain[13].
 - Transporter occupancy was calculated from a graphical occupancy plot, relating the binding potential of the radioligand in the presence and absence of the drug to the plasma concentration of **PF-03463275**[10].
 - This allowed for the determination of the drug dose required to achieve 50% of the maximum occupancy (ID50) and the plasma concentration for 50% occupancy (IC50)[10].

Assessment of NMDAR-Mediated Neuroplasticity

This protocol aimed to evaluate the effects of **PF-03463275** on long-term potentiation (LTP), a measure of synaptic plasticity.

- Subjects: Healthy volunteers and patients with schizophrenia[10].
- Method: Electroencephalography (EEG) was used to measure visual long-term potentiation (LTP)[10].
- Procedure:
 - Baseline visual evoked potentials (VEPs) were recorded[10].
 - A visual tetanus stimulus was applied to induce LTP[10].

- Post-tetanus VEPs were recorded to measure the change in amplitude from baseline, which indicates the degree of LTP[10].
- This procedure was conducted under different dosing conditions of **PF-03463275** (placebo, 10 mg, 20 mg, 40 mg, and 60 mg BID)[10].
- Results indicated a peak enhancement of LTP in schizophrenia patients at the 40 mg BID dose, suggesting an inverted 'U' dose-response relationship[14][10][11].

Clinical Trial for Cognitive Impairment in Schizophrenia (NCT01911676)

This study investigated the efficacy of **PF-03463275** in enhancing the effects of cognitive training on cognitive impairment associated with schizophrenia[8][15].

- Design: A double-blind, placebo-controlled, within-subject, crossover augmentation study[15][16].
- Participants: Stable outpatients with schizophrenia[15].
- Procedure:
 - Participants were enrolled if they were cytochrome P450 2D6 extensive metabolizers to limit pharmacokinetic variability[15][16].
 - The study consisted of two 5-week treatment periods separated by a 2-week washout period[15][16].
 - In each period, participants received either **PF-03463275** (40 or 60 mg twice daily) or a placebo[15][16].
 - Participants engaged in 4 weeks of computerized cognitive training during each treatment period[16].
 - Cognitive performance was assessed using the MATRICS Consensus Cognitive Battery (MCCB)[15].

- Medication adherence was monitored daily via videoconferencing[16].

Signaling Pathway and Experimental Workflow

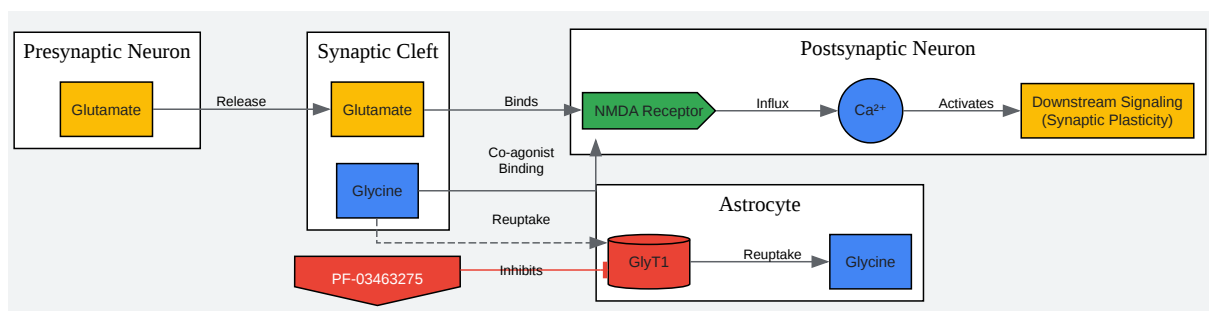

[Click to download full resolution via product page](#)

Caption: Mechanism of **PF-03463275** action at the glutamatergic synapse.

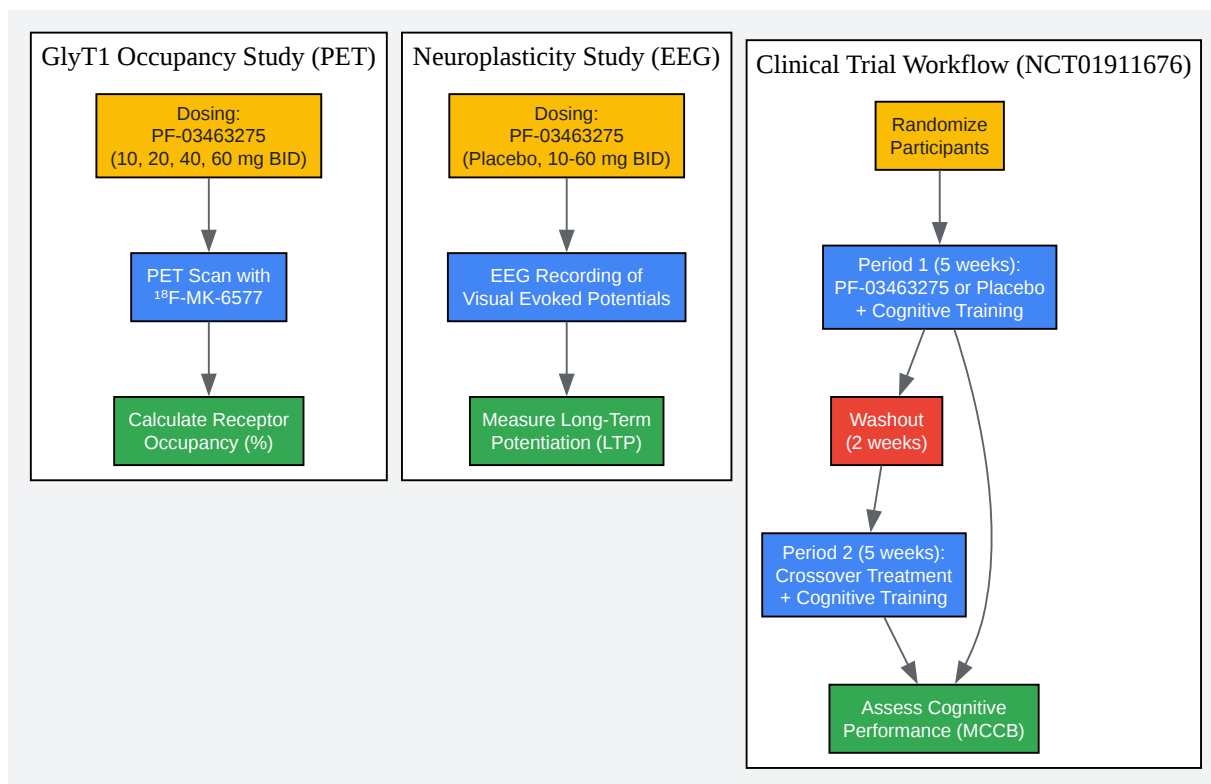

[Click to download full resolution via product page](#)

Caption: Overview of key experimental workflows for **PF-03463275**.

Need Custom Synthesis?

BenchChem offers custom synthesis for rare earth carbides and specific isotopic labeling.
Email: info@benchchem.com or [Request Quote Online](#).

References

- 1. glpbio.com [glpbio.com]

- 2. PF-03463275 | GlyT1 inhibitor | Probechem Biochemicals [probechem.com]
- 3. Compound PF-03463275 - Chemdiv [chemdiv.com]
- 4. PF-03463275 | Ligand page | IUPHAR/BPS Guide to PHARMACOLOGY [guidetopharmacology.org]
- 5. medchemexpress.com [medchemexpress.com]
- 6. medchemexpress.com [medchemexpress.com]
- 7. Frontiers | Directly and Indirectly Targeting the Glycine Modulatory Site to Modulate NMDA Receptor Function to Address Unmet Medical Needs of Patients With Schizophrenia [frontiersin.org]
- 8. go.drugbank.com [go.drugbank.com]
- 9. researchgate.net [researchgate.net]
- 10. Dose-related target occupancy and effects on circuitry, behavior, and neuroplasticity of the glycine transporter-1 inhibitor, PF-03463275, in healthy and schizophrenia subjects - PMC [pmc.ncbi.nlm.nih.gov]
- 11. Dose-Related Target Occupancy and Effects on Circuitry, Behavior, and Neuroplasticity of the Glycine Transporter-1 Inhibitor PF-03463275 in Healthy and Schizophrenia Subjects - PubMed [pubmed.ncbi.nlm.nih.gov]
- 12. forum.schizophrenia.com [forum.schizophrenia.com]
- 13. RePORT) RePORTER [reporter.nih.gov]
- 14. Development of the novel GlyT1 inhibitor, iclepertin (BI 425809), for the treatment of cognitive impairment associated with schizophrenia - PMC [pmc.ncbi.nlm.nih.gov]
- 15. Randomized controlled trial of the glycine transporter 1 inhibitor PF-03463275 to enhance cognitive training and neuroplasticity in schizophrenia [pubmed.ncbi.nlm.nih.gov]
- 16. Randomized Controlled Trial of the Glycine Transporter 1 Inhibitor PF-03463275 to Enhance Cognitive Training and Neuroplasticity in Schizophrenia - PMC [pmc.ncbi.nlm.nih.gov]
- To cite this document: BenchChem. [PF-03463275 CAS number and synonyms]. BenchChem, [2025]. [Online PDF]. Available at: [https://www.benchchem.com/product/b1461716#pf-03463275-cas-number-and-synonyms]

Disclaimer & Data Validity:

The information provided in this document is for Research Use Only (RUO) and is strictly not intended for diagnostic or therapeutic procedures. While BenchChem strives to provide accurate protocols, we make no warranties, express or implied, regarding the fitness of this product for every specific experimental setup.

Technical Support: The protocols provided are for reference purposes. Unsure if this reagent suits your experiment? [[Contact our Ph.D. Support Team for a compatibility check](#)]

Need Industrial/Bulk Grade? [Request Custom Synthesis Quote](#)

BenchChem

Our mission is to be the trusted global source of essential and advanced chemicals, empowering scientists and researchers to drive progress in science and industry.

Contact

Address: 3281 E Guasti Rd
Ontario, CA 91761, United States
Phone: (601) 213-4426
Email: info@benchchem.com