

Otophyllside O: A Technical Whitepaper on its Discovery, Origin, and Biological Potential

Author: BenchChem Technical Support Team. **Date:** December 2025

Compound of Interest

Compound Name: Otophyllside O

Cat. No.: B1496093

[Get Quote](#)

For Researchers, Scientists, and Drug Development Professionals

Abstract

Otophyllside O, a C21 steroidal glycoside, represents a class of promising bioactive natural products isolated from the roots of *Cynanchum otophyllum*. This technical guide provides a comprehensive overview of its discovery, botanical origin, and putative biological activities based on existing research on related compounds. While specific quantitative data and detailed mechanistic studies on **Otophyllside O** are still emerging, this paper consolidates the available information on closely related C21 steroidal glycosides from the same plant source to offer insights into its potential therapeutic applications. This document outlines generalized experimental protocols for its isolation and biological evaluation and visualizes potential signaling pathways that may be modulated by this class of compounds.

Discovery and Origin

Otophyllside O is a naturally occurring C21 steroidal glycoside identified from the roots of the plant *Cynanchum otophyllum*[1]. This plant, belonging to the Asclepiadaceae family, has been a source of numerous bioactive steroidal compounds. The initial discovery and structural elucidation of **Otophyllside O** and its congeners have been primarily achieved through meticulous phytochemical investigations of extracts from the roots of this plant. These studies have revealed a rich diversity of C21 steroidal glycosides within *Cynanchum otophyllum*, many of which have demonstrated significant biological activities, including cytotoxic and neuroprotective effects.

Chemical Structure

While the precise structure of **Otophyllaside O** is defined by its unique glycosidic linkages and stereochemistry, it shares the fundamental C21 steroidal aglycone core common to this class of compounds. The structural characterization of these complex natural products typically involves a combination of advanced spectroscopic techniques, including 1D and 2D Nuclear Magnetic Resonance (NMR) spectroscopy and High-Resolution Mass Spectrometry (HRMS).

Potential Biological Activities and Quantitative Data

Direct quantitative data on the biological activity of **Otophyllaside O**, such as IC50 or EC50 values, is not yet prominently available in the public domain. However, studies on other C21 steroidal glycosides isolated from *Cynanchum otophyllum* provide valuable insights into its potential cytotoxic properties against various cancer cell lines. The tables below summarize the reported cytotoxic activities of several related C21 steroidal glycosides from the same plant. It is important to note that these are for compounds structurally related to **Otophyllaside O** and should be considered indicative of its potential activity.

Table 1: Cytotoxic Activities of C21 Steroidal Glycosides from *Cynanchum otophyllum*

Compound	Cell Line	IC50 (μM)	Reference
Cyanotin E	HL-60	11.4	[2]
Cyanotin G	HL-60	12.2	[2]
Cyanotin H	HL-60	15.6	[2]
Otophyllaside B	HL-60	25.8	[3]
Caudatin 3-O- β -D-cymaropyranosyl-(1 \rightarrow 4)- β -D-cymaropyranoside	HCT-116	Not specified, but showed selective cytotoxicity	[3]

Table 2: Further Cytotoxic Activities of Compounds from *Cynanchum* Species

Compound	Cell Line	IC50 (μM)	Reference
Cynanotins (unspecified)	MCF-7	16.1 - 25.6	[2]
Cynanotins (unspecified)	SMMC-7721	11.4 - 36.7	[2]
Cynanotins (unspecified)	A-549	11.4 - 36.7	[2]
Cynanotins (unspecified)	SW480	12.2 - 30.8	[2]

Experimental Protocols

General Protocol for Isolation and Purification of C21 Steroidal Glycosides from *Cynanchum otophyllum*

The following is a generalized procedure based on methodologies reported for the isolation of C21 steroidal glycosides from *Cynanchum otophyllum*. Specific details for **Otophyllside O** may vary.

- **Extraction:** The air-dried and powdered roots of *Cynanchum otophyllum* are typically extracted exhaustively with a solvent such as 95% ethanol or methanol at room temperature. The resulting extract is then concentrated under reduced pressure to yield a crude extract.
- **Fractionation:** The crude extract is suspended in water and partitioned successively with solvents of increasing polarity, such as petroleum ether, chloroform, and n-butanol, to separate compounds based on their polarity. The C21 steroidal glycosides are often enriched in the chloroform and n-butanol fractions.
- **Chromatographic Separation:** The enriched fractions are subjected to a series of chromatographic techniques for further separation and purification. This multi-step process often includes:
 - **Silica Gel Column Chromatography:** The fraction is applied to a silica gel column and eluted with a gradient of solvents, typically a mixture of chloroform and methanol, to yield

several sub-fractions.

- Medium Pressure Liquid Chromatography (MPLC): Sub-fractions are further purified on octadecylsilyl (ODS) columns using a stepwise gradient of methanol in water.
- High-Performance Liquid Chromatography (HPLC): Final purification to obtain the pure **Otophyllaside O** is achieved using semi-preparative or preparative HPLC, often with a C18 column and a mobile phase consisting of a methanol-water or acetonitrile-water gradient.
- Structure Elucidation: The structure of the isolated pure compound is then determined using spectroscopic methods, including ^1H NMR, ^{13}C NMR, 2D NMR (COSY, HSQC, HMBC), and HR-ESI-MS.

General Protocol for In Vitro Cytotoxicity Assay (MTT Assay)

The following protocol describes a general method for assessing the cytotoxic activity of a compound like **Otophyllaside O** against cancer cell lines.

- Cell Culture: Human cancer cell lines (e.g., HL-60, SMMC-7721, A-549, MCF-7, SW480) are cultured in an appropriate medium (e.g., RPMI-1640 or DMEM) supplemented with 10% fetal bovine serum (FBS) and 1% penicillin-streptomycin, and maintained in a humidified incubator at 37°C with 5% CO₂.
- Cell Seeding: Cells are seeded into 96-well plates at a density of approximately 5×10^3 to 1×10^4 cells per well and allowed to adhere overnight.
- Compound Treatment: The test compound (**Otophyllaside O**) is dissolved in a suitable solvent (e.g., DMSO) to prepare a stock solution. Serial dilutions are then made in the culture medium to achieve a range of final concentrations. The cells are treated with these different concentrations of the compound for a specified period, typically 48 or 72 hours. A vehicle control (medium with DMSO) and a positive control (a known cytotoxic drug like cisplatin) are also included.
- MTT Assay: After the incubation period, 20 μL of MTT solution (5 mg/mL in PBS) is added to each well, and the plate is incubated for another 4 hours at 37°C. The MTT-containing

medium is then removed, and 150 μ L of DMSO is added to each well to dissolve the formazan crystals.

- **Data Analysis:** The absorbance is measured at a wavelength of 490 nm or 570 nm using a microplate reader. The cell viability is calculated as a percentage of the vehicle control. The IC50 value, the concentration of the compound that inhibits cell growth by 50%, is then determined by plotting the cell viability against the compound concentration and fitting the data to a sigmoidal dose-response curve.

Potential Signaling Pathways and Mechanisms of Action

While the specific signaling pathways modulated by **Otophyllaside O** have not been elucidated, research on other C21 steroidal glycosides from *Cynanchum* species suggests potential mechanisms of action. Studies on total C-21 steroidal glycosides from a related species, *Cynanchum auriculatum*, have shown that they can attenuate oxidative injury and inflammation by modulating the Nrf2 and NF- κ B signaling pathways[4]. It is plausible that **Otophyllaside O** may exert its biological effects through similar mechanisms.

Nrf2 Signaling Pathway

The Nrf2 pathway is a critical regulator of the cellular antioxidant response. Under normal conditions, Nrf2 is kept in the cytoplasm by Keap1 and targeted for degradation. Upon exposure to oxidative stress or certain bioactive compounds, Nrf2 is released from Keap1, translocates to the nucleus, and binds to the Antioxidant Response Element (ARE), leading to the transcription of various antioxidant and cytoprotective genes.

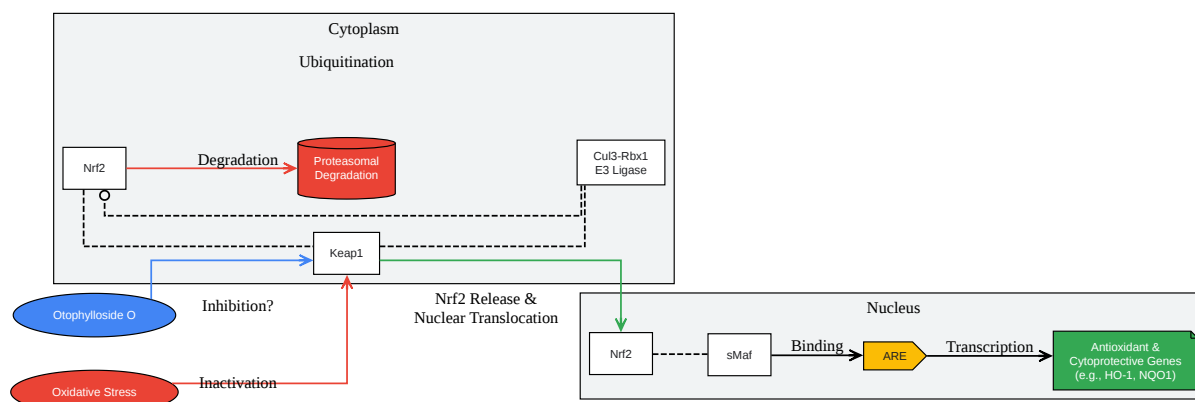

[Click to download full resolution via product page](#)

Potential modulation of the Nrf2 signaling pathway by **Otophyllside O**.

NF- κ B Signaling Pathway

The NF- κ B pathway is a key regulator of inflammation, immunity, and cell survival. In its inactive state, NF- κ B is sequestered in the cytoplasm by I κ B proteins. Upon stimulation by various signals, the I κ B kinase (IKK) complex phosphorylates I κ B, leading to its ubiquitination and proteasomal degradation. This allows NF- κ B to translocate to the nucleus and activate the transcription of pro-inflammatory and other target genes.

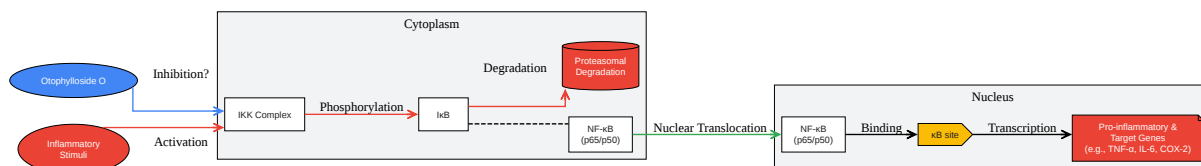

[Click to download full resolution via product page](#)

Potential modulation of the NF-κB signaling pathway by **Otophyllaside O**.

Experimental Workflow Overview

The following diagram illustrates a general workflow for the discovery and initial biological evaluation of a natural product like **Otophyllaside O**.

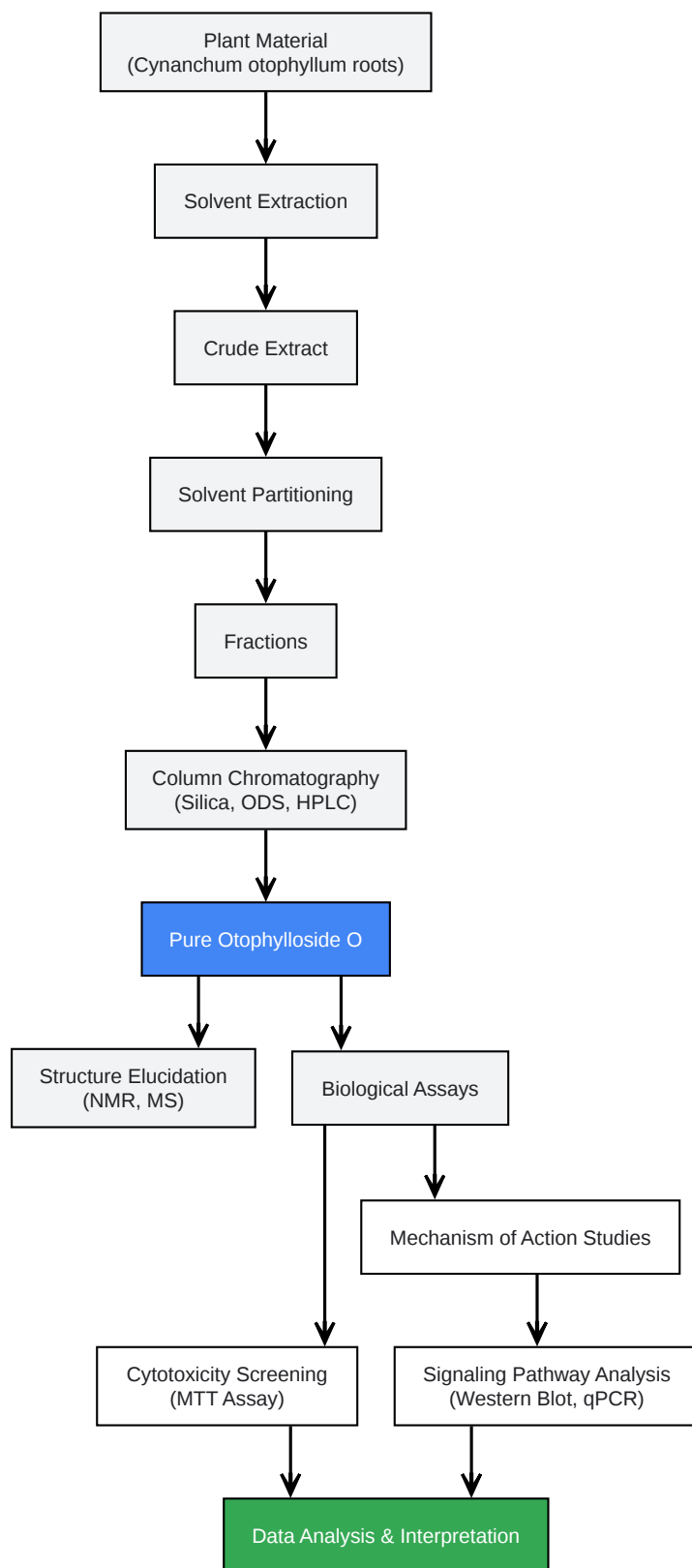

[Click to download full resolution via product page](#)

General experimental workflow for **Otophyllaside O** research.

Conclusion and Future Directions

Otophyllside O, a C21 steroidal glycoside from *Cynanchum otophyllum*, belongs to a class of natural products with demonstrated cytotoxic potential. While direct experimental data for **Otophyllside O** remains limited, the information available for structurally related compounds suggests it is a promising candidate for further investigation in the context of drug discovery, particularly in oncology.

Future research should focus on:

- The complete isolation and purification of **Otophyllside O** in sufficient quantities for comprehensive biological testing.
- Determination of its specific IC50 values against a broad panel of human cancer cell lines.
- In-depth studies to elucidate its precise mechanism of action and identify the specific signaling pathways it modulates.
- In vivo studies to evaluate its efficacy and safety in animal models.

The information compiled in this technical guide serves as a foundational resource for researchers and drug development professionals interested in the therapeutic potential of **Otophyllside O** and other related C21 steroidal glycosides.

Need Custom Synthesis?

BenchChem offers custom synthesis for rare earth carbides and specific isotopic labeling.

Email: info@benchchem.com or [Request Quote Online](#).

References

- 1. New pregnane glycosides from the roots of *Cynanchum otophyllum* - PubMed [pubmed.ncbi.nlm.nih.gov]
- 2. C21 steroidal glycosides with cytotoxic activities from *Cynanchum otophyllum* - PubMed [pubmed.ncbi.nlm.nih.gov]
- 3. [researchgate.net](https://www.researchgate.net) [[researchgate.net](https://www.researchgate.net)]

- 4. Total C-21 steroidal glycosides, isolated from the root tuber of *Cynanchum auriculatum* Royle ex Wight, attenuate hydrogen peroxide-induced oxidative injury and inflammation in L02 cells - PMC [pmc.ncbi.nlm.nih.gov]
- To cite this document: BenchChem. [Otophyllósíde O: A Technical Whitepaper on its Discovery, Origin, and Biological Potential]. BenchChem, [2025]. [Online PDF]. Available at: [https://www.benchchem.com/product/b1496093#otophylloside-o-discovery-and-origin]

Disclaimer & Data Validity:

The information provided in this document is for Research Use Only (RUO) and is strictly not intended for diagnostic or therapeutic procedures. While BenchChem strives to provide accurate protocols, we make no warranties, express or implied, regarding the fitness of this product for every specific experimental setup.

Technical Support: The protocols provided are for reference purposes. Unsure if this reagent suits your experiment? [[Contact our Ph.D. Support Team for a compatibility check](#)]

Need Industrial/Bulk Grade? [Request Custom Synthesis Quote](#)

BenchChem

Our mission is to be the trusted global source of essential and advanced chemicals, empowering scientists and researchers to drive progress in science and industry.

Contact

Address: 3281 E Guasti Rd

Ontario, CA 91761, United States

Phone: (601) 213-4426

Email: info@benchchem.com