

Orthogonal methods to validate findings from photo-crosslinking experiments.

Author: BenchChem Technical Support Team. **Date:** December 2025

Compound of Interest

Compound Name: *Fmoc-L-Photo-Leucine*

Cat. No.: *B2471353*

[Get Quote](#)

Validating Photo-Crosslinking Findings: A Guide to Orthogonal Methods

For researchers, scientists, and drug development professionals, the identification of protein-protein interactions (PPIs) is crucial for understanding cellular processes and developing targeted therapeutics. Photo-crosslinking has emerged as a powerful technique to capture these interactions in their native cellular environment. However, the transient and often low-affinity nature of many PPIs necessitates rigorous validation of photo-crosslinking findings using orthogonal methods. This guide provides a comprehensive comparison of key orthogonal techniques, offering experimental insights and data to ensure the confidence and accuracy of your results.

Photo-crosslinking methods utilize photo-activatable amino acid analogs or small molecule crosslinkers to covalently link interacting proteins upon UV irradiation. This "freezes" interactions in time, allowing for their subsequent identification by techniques like mass spectrometry. While highly effective, the potential for non-specific crosslinking and the identification of indirect interactors underscores the importance of independent validation.

Comparison of Orthogonal Validation Methods

To aid in the selection of the most appropriate validation strategy, the following table summarizes the key characteristics of several widely used orthogonal methods.

Method	Principle	Throughput	Quantitative Data	Key Strengths	Key Limitations
Co-Immunoprecipitation (Co-IP)	An antibody targets a known "bait" protein, pulling it down from a cell lysate along with its interacting "prey" proteins.	Low to Medium	Relative quantification (e.g., Western Blot band intensity)	Considered the "gold standard" for in vivo interaction validation. Detects interactions in a cellular context.	Dependent on high-quality antibodies. May miss transient or weak interactions. Potential for antibody-related artifacts.
Surface Plasmon Resonance (SPR)	Measures changes in the refractive index at a sensor chip surface as an analyte flows over an immobilized ligand, providing real-time binding kinetics.	Medium	Association rate (k_a), dissociation rate (k_d), and affinity (KD)	Provides detailed kinetic and affinity data. Label-free.	Requires purified proteins. Immobilization of one partner may affect its conformation and binding.
Bio-Layer Interferometry (BLI)	Measures the interference pattern of light reflected from a biosensor tip as molecules bind and	High	Association rate (k_a), dissociation rate (k_d), and affinity (KD)	High-throughput and compatible with crude samples. Label-free.	Generally less sensitive than SPR. Requires immobilization of one partner.

dissociate,
providing
real-time
binding
kinetics.

Förster Resonance Energy Transfer (FRET)	Measures the non-radiative transfer of energy from a donor fluorophore to an acceptor fluorophore when in close proximity (1-10 nm).	Low to High	FRET efficiency, apparent distance	Can be performed in living cells, providing spatial and temporal information.	Requires genetically encoded or chemically labeled fluorescent proteins. Distance and orientation dependent.
Bioluminescence Resonance Energy Transfer (BRET)	Measures the non-radiative transfer of energy from a bioluminescent donor (luciferase) to a fluorescent acceptor when in close proximity.	High	BRET ratio	High signal-to-noise ratio in living cells as it does not require external excitation.	Requires genetically encoded fusion proteins. Less spatial resolution than FRET.

Experimental Workflows and Signaling Pathways

A typical workflow for validating a protein-protein interaction identified through a photo-crosslinking experiment involves a multi-pronged approach.

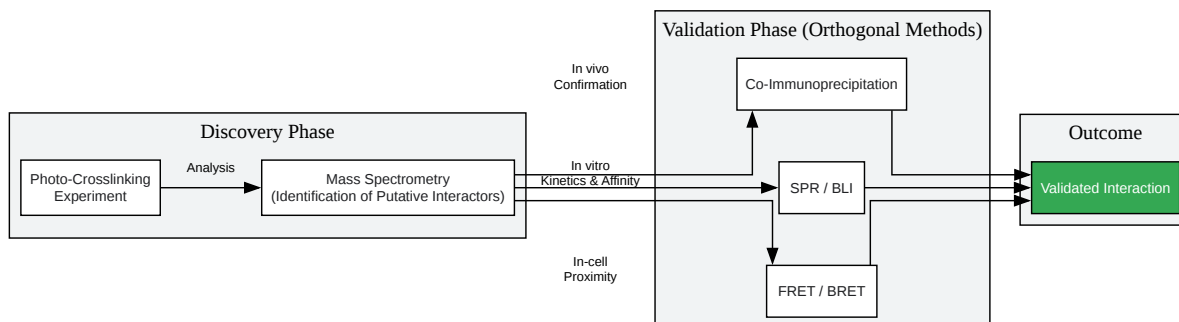

[Click to download full resolution via product page](#)

Figure 1. A generalized workflow for the validation of protein-protein interactions identified by photo-crosslinking.

A practical application of these validation methods can be seen in the study of signaling pathways, such as the Epidermal Growth Factor Receptor (EGFR) pathway, which is crucial in cell proliferation and is often dysregulated in cancer.

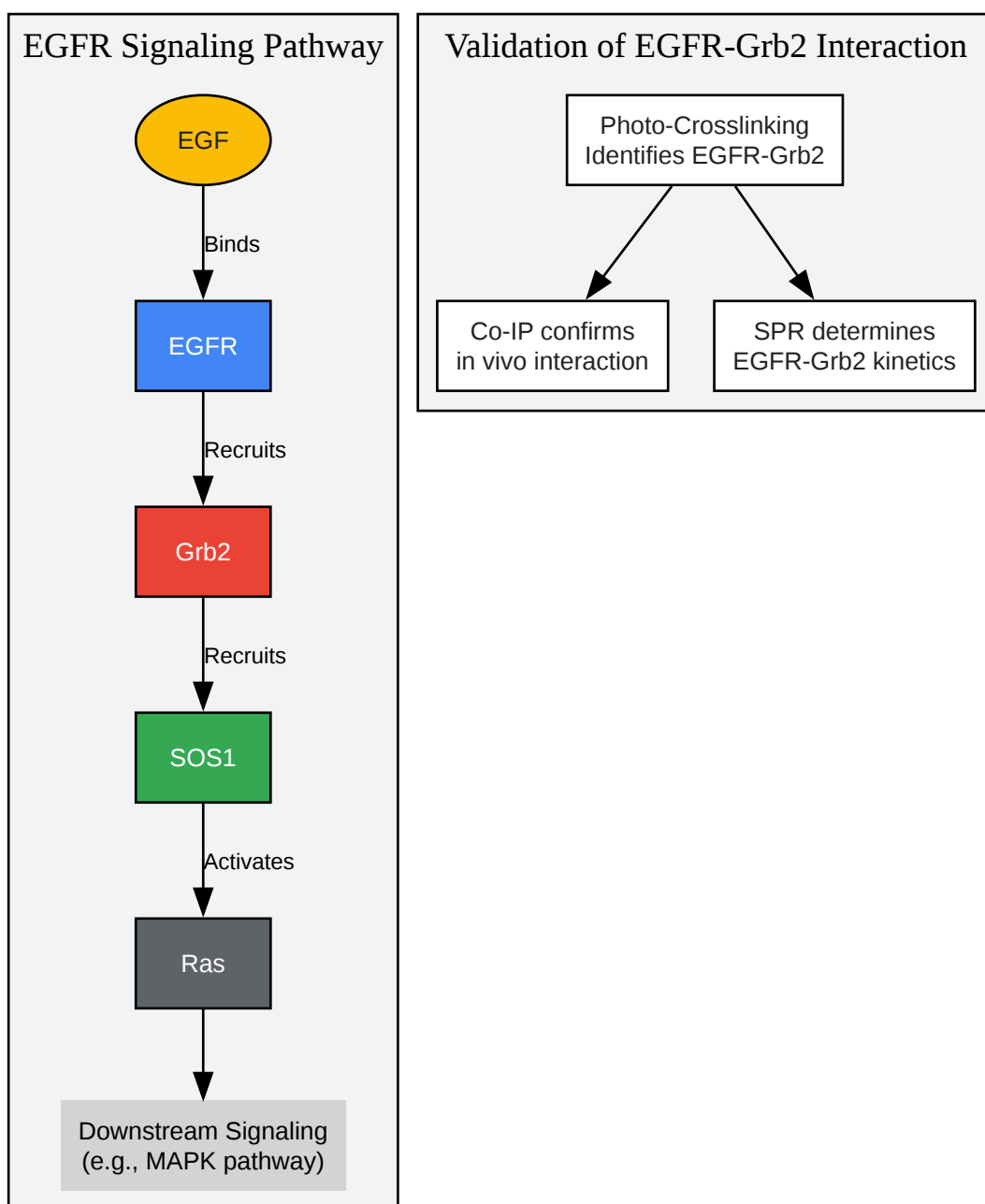

[Click to download full resolution via product page](#)

Figure 2. Validation of the EGFR-Grb2 interaction within the EGFR signaling pathway.

Detailed Experimental Protocols

Co-Immunoprecipitation (Co-IP) to Validate a Photo-Crosslinking Hit

This protocol outlines the general steps for validating a putative interaction between a "bait" protein (the target of the photo-crosslinking experiment) and a "prey" protein (a potential interactor identified by mass spectrometry).

Materials:

- Cell lysate from cells expressing the bait and prey proteins.
- IP Lysis/Wash Buffer (e.g., 50 mM Tris-HCl pH 7.4, 150 mM NaCl, 1 mM EDTA, 1% NP-40, with protease and phosphatase inhibitors).
- Antibody specific to the bait protein.
- Protein A/G magnetic beads or agarose resin.
- Elution Buffer (e.g., 0.1 M Glycine-HCl, pH 2.5 or SDS-PAGE sample buffer).
- Antibodies for Western blotting (anti-bait and anti-prey).

Procedure:

- Cell Lysis: Lyse cells in IP Lysis/Wash Buffer on ice for 30 minutes.
- Clarification: Centrifuge the lysate at 14,000 x g for 15 minutes at 4°C to pellet cellular debris.
- Pre-clearing (Optional): Incubate the supernatant with Protein A/G beads for 1 hour at 4°C to reduce non-specific binding.
- Immunoprecipitation: Incubate the pre-cleared lysate with the anti-bait antibody for 2-4 hours or overnight at 4°C with gentle rotation.
- Capture: Add Protein A/G beads and incubate for another 1-2 hours at 4°C.
- Washing: Pellet the beads and wash 3-5 times with cold IP Lysis/Wash Buffer.
- Elution: Elute the protein complexes from the beads using Elution Buffer.

- Analysis: Analyze the eluate by SDS-PAGE and Western blotting using antibodies against both the bait and prey proteins. A band corresponding to the prey protein in the immunoprecipitated sample indicates an interaction.[1][2][3]

Surface Plasmon Resonance (SPR) for Kinetic Analysis

This protocol describes the determination of binding kinetics for a validated interaction.

Materials:

- Purified bait and prey proteins.
- SPR instrument and sensor chip (e.g., CM5).
- Immobilization buffer (e.g., 10 mM sodium acetate, pH 4.5).
- Amine coupling kit (EDC, NHS).
- Running buffer (e.g., HBS-EP+).
- Regeneration solution (e.g., 10 mM glycine-HCl, pH 1.5).

Procedure:

- Ligand Immobilization: Covalently immobilize the bait protein (ligand) onto the sensor chip surface using amine coupling chemistry.
- Analyte Injection: Inject a series of concentrations of the prey protein (analyte) over the sensor surface.
- Association & Dissociation: Monitor the binding (association) and unbinding (dissociation) in real-time.
- Regeneration: After each analyte injection, regenerate the sensor surface by injecting the regeneration solution to remove the bound analyte.
- Data Analysis: Fit the sensorgram data to a suitable binding model (e.g., 1:1 Langmuir) to determine the association rate (k_a), dissociation rate (k_d), and equilibrium dissociation

constant (KD).[4][5]

Bio-Layer Interferometry (BLI) for High-Throughput Screening

This protocol outlines a high-throughput method to screen multiple potential interactors.

Materials:

- BLI instrument (e.g., Octet system).
- Biosensors (e.g., Streptavidin-coated).
- Biotinylated bait protein.
- Purified prey proteins or cell lysates.
- Assay buffer.

Procedure:

- Baseline: Equilibrate the biosensors in the assay buffer to establish a baseline.
- Loading: Immobilize the biotinylated bait protein onto the streptavidin-coated biosensors.
- Second Baseline: Establish a new baseline for the immobilized biosensors.
- Association: Dip the biosensors into wells containing different prey proteins to measure association.
- Dissociation: Transfer the biosensors back to buffer-containing wells to measure dissociation.
- Data Analysis: Analyze the resulting binding curves to determine kinetic parameters (k_a , k_d , KD) for each interaction.

Förster Resonance Energy Transfer (FRET) for In-Cell Validation

This protocol describes how to validate a PPI within living cells.

Materials:

- Expression vectors for the bait protein fused to a donor fluorophore (e.g., CFP) and the prey protein fused to an acceptor fluorophore (e.g., YFP).
- Mammalian cell line and transfection reagents.
- Fluorescence microscope equipped for FRET imaging.

Procedure:

- Transfection: Co-transfect cells with the donor- and acceptor-fused protein expression vectors.
- Cell Culture: Culture the cells for 24-48 hours to allow for protein expression and localization.
- Imaging: Image the cells using a fluorescence microscope. Acquire images in the donor, acceptor, and FRET channels.
- Data Analysis: Calculate the FRET efficiency. A common method is acceptor photobleaching, where the acceptor is selectively photobleached, and the increase in donor fluorescence is measured. An increase in donor fluorescence after acceptor bleaching indicates FRET and thus proximity of the two proteins.

Bioluminescence Resonance Energy Transfer (BRET) for In-Cell Interaction Studies

This protocol provides a method for studying PPIs in living cells with high sensitivity.

Materials:

- Expression vectors for the bait protein fused to a luciferase (e.g., Renilla luciferase, Rluc) and the prey protein fused to a fluorescent acceptor (e.g., YFP).

- Mammalian cell line and transfection reagents.
- Luciferase substrate (e.g., coelenterazine).
- Luminometer capable of measuring BRET.

Procedure:

- Transfection: Co-transfect cells with the donor and acceptor fusion constructs.
- Cell Plating: Plate the transfected cells in a multi-well plate.
- Substrate Addition: Add the luciferase substrate to the cells.
- Signal Detection: Immediately measure the luminescence emission at the donor and acceptor wavelengths using a luminometer.
- Data Analysis: Calculate the BRET ratio (acceptor emission / donor emission). An increased BRET ratio compared to control conditions (e.g., expression of donor with an unrelated acceptor) indicates an interaction.

Conclusion

The validation of protein-protein interactions identified through photo-crosslinking is a critical step in ensuring the biological relevance of the findings. By employing a combination of orthogonal methods, researchers can build a robust body of evidence to confirm interactions, elucidate their kinetics and affinity, and study their dynamics within the complex environment of a living cell. The choice of validation method will depend on the specific research question, the nature of the interacting proteins, and the available resources. A multi-faceted approach, as outlined in this guide, will ultimately lead to a more comprehensive and reliable understanding of the intricate networks that govern cellular function.

Need Custom Synthesis?

BenchChem offers custom synthesis for rare earth carbides and specific isotopic labeling.

Email: info@benchchem.com or [Request Quote Online](#).

References

- 1. Quantitative Photo-crosslinking Mass Spectrometry Revealing Protein Structure Response to Environmental Changes - PMC [pmc.ncbi.nlm.nih.gov]
- 2. Photocrosslinking Approach to Investigate Protein Interactions in the BCL-2 Family - PubMed [pubmed.ncbi.nlm.nih.gov]
- 3. researchgate.net [researchgate.net]
- 4. researchgate.net [researchgate.net]
- 5. How to Analyze Protein-Protein Interaction: Top Lab Techniques - Creative Proteomics [creative-proteomics.com]
- To cite this document: BenchChem. [Orthogonal methods to validate findings from photo-crosslinking experiments.]. BenchChem, [2025]. [Online PDF]. Available at: [https://www.benchchem.com/product/b2471353#orthogonal-methods-to-validate-findings-from-photo-crosslinking-experiments]

Disclaimer & Data Validity:

The information provided in this document is for Research Use Only (RUO) and is strictly not intended for diagnostic or therapeutic procedures. While BenchChem strives to provide accurate protocols, we make no warranties, express or implied, regarding the fitness of this product for every specific experimental setup.

Technical Support: The protocols provided are for reference purposes. Unsure if this reagent suits your experiment? [[Contact our Ph.D. Support Team for a compatibility check](#)]

Need Industrial/Bulk Grade? [Request Custom Synthesis Quote](#)

BenchChem

Our mission is to be the trusted global source of essential and advanced chemicals, empowering scientists and researchers to drive progress in science and industry.

Contact

Address: 3281 E Guasti Rd
Ontario, CA 91761, United States
Phone: (601) 213-4426
Email: info@benchchem.com

