

Optimizing Isophysalin G Concentration for Cell Treatment: A Technical Support Guide

Author: BenchChem Technical Support Team. **Date:** December 2025

Compound of Interest

Compound Name: *Isophysalin G*

Cat. No.: *B12089377*

[Get Quote](#)

For Researchers, Scientists, and Drug Development Professionals

This technical support center provides comprehensive guidance for researchers utilizing **Isophysalin G** in cell-based assays. This document offers troubleshooting advice, frequently asked questions (FAQs), detailed experimental protocols, and summaries of key quantitative data to facilitate the effective application of **Isophysalin G** in your research.

Frequently Asked Questions (FAQs)

Q1: What is **Isophysalin G** and what is its primary mechanism of action?

A1: **Isophysalin G** is a member of the physalin family of steroidal lactones derived from plants of the *Physalis* genus. Physalins, including **Isophysalin G**, are recognized for their anti-inflammatory and anti-cancer properties.^{[1][2]} The primary mechanisms of action involve the modulation of key signaling pathways, including the inhibition of Nuclear Factor-kappa B (NF-κB) and Signal Transducer and Activator of Transcription 3 (STAT3).^{[3][4][5]} By inhibiting these pathways, **Isophysalin G** can suppress inflammatory responses and induce apoptosis and cell cycle arrest in cancer cells.

Q2: How should I dissolve and store **Isophysalin G**?

A2: **Isophysalin G** is sparingly soluble in aqueous solutions. It is recommended to prepare a concentrated stock solution in dimethyl sulfoxide (DMSO). For example, a 10 mM stock solution can be prepared and stored in small aliquots at -20°C or -80°C to minimize freeze-

thaw cycles. When preparing your working concentrations, dilute the DMSO stock solution in your cell culture medium. It is crucial to ensure the final DMSO concentration in your cell culture does not exceed a level that is toxic to your specific cell line, typically below 0.5%.

Q3: What is a recommended starting concentration range for **Isophysalin G** in a new cell line?

A3: For a new cell line, it is advisable to perform a dose-response experiment to determine the optimal concentration. Based on studies with related physalins, a broad range of concentrations from 0.1 μM to 100 μM can be tested initially. The half-maximal inhibitory concentration (IC₅₀) will vary depending on the cell line's sensitivity.

Q4: I am not observing the expected cytotoxic effects. What are the possible reasons?

A4: Several factors could contribute to a lack of cytotoxic effects. Please refer to the troubleshooting section below for a detailed guide on how to address this issue.

Troubleshooting Guide

Problem	Possible Cause	Suggested Solution
No or low cytotoxicity observed	Sub-optimal concentration of Isophysalin G: The concentration used may be too low for the specific cell line.	Perform a dose-response study with a wider range of concentrations (e.g., 0.1 μ M to 100 μ M) to determine the IC50 value for your cell line.
Cell line resistance: The target signaling pathways (e.g., NF- κ B, STAT3) may not be constitutively active or critical for survival in your cell line.	Characterize the baseline activity of the NF- κ B and STAT3 pathways in your cell line using techniques like western blotting for phosphorylated key proteins. Consider using a positive control cell line known to be sensitive to physalins.	
Incorrect drug preparation or storage: The Isophysalin G stock solution may have degraded.	Prepare a fresh stock solution of Isophysalin G in DMSO and store it in small aliquots at -20°C or -80°C. Avoid repeated freeze-thaw cycles.	
High cell seeding density: A high number of cells can diminish the effective concentration of the compound per cell.	Optimize the cell seeding density for your viability assay. Ensure cells are in the exponential growth phase during treatment.	
Precipitation of Isophysalin G in culture medium	Poor solubility: Isophysalin G has limited solubility in aqueous media.	Ensure the final DMSO concentration is sufficient to maintain solubility but remains non-toxic to the cells (typically <0.5%). Prepare working solutions by diluting the DMSO stock in pre-warmed culture medium and vortexing thoroughly.

High background in control wells (vehicle-treated)	DMSO toxicity: The concentration of DMSO used as a vehicle may be toxic to the cells.	Perform a vehicle control experiment with varying concentrations of DMSO to determine the maximum non-toxic concentration for your cell line.
Inconsistent results between experiments	Variability in cell culture conditions: Differences in cell passage number, confluency, or media composition can affect experimental outcomes.	Maintain consistent cell culture practices. Use cells within a defined passage number range and ensure similar confluency at the time of treatment.
Pipetting errors: Inaccurate pipetting can lead to variations in drug concentration.	Use calibrated pipettes and ensure proper mixing of solutions.	

Quantitative Data Summary

The following tables summarize the cytotoxic effects of physalins on various cancer cell lines. While specific IC50 values for **Isophysalin G** are not widely available, the data for related physalins (B and D) can provide a valuable reference for designing initial dose-response experiments.

Table 1: In Vitro Cytotoxicity of Physalin B

Cell Line	Cancer Type	IC50 (µg/mL)
HL-60	Promyelocytic Leukemia	0.58
SF-295	Glioblastoma	1.36
MDA-MB-435	Melanoma	15.18
HCT-8	Colon Cancer	1.12

Data adapted from a study on the in-vitro and in-vivo antitumour activity of physalins B and D.

Table 2: In Vitro Cytotoxicity of Physalin D

Cell Line	Cancer Type	IC50 (µg/mL)
HL-60	Promyelocytic Leukemia	0.28
SF-295	Glioblastoma	0.42
MDA-MB-435	Melanoma	2.43
HCT-8	Colon Cancer	0.35

Data adapted from a study on the in-vitro and in-vivo antitumour activity of physalins B and D.

Experimental Protocols

Protocol 1: Determining the IC50 of Isophysalin G using MTT Assay

Objective: To determine the concentration of **Isophysalin G** that inhibits cell viability by 50%.

Materials:

- Target cancer cell line
- Complete cell culture medium
- **Isophysalin G**
- DMSO
- 96-well cell culture plates
- MTT (3-(4,5-dimethylthiazol-2-yl)-2,5-diphenyltetrazolium bromide) solution (5 mg/mL in PBS)
- Solubilization solution (e.g., DMSO or 10% SDS in 0.01 M HCl)
- Microplate reader

Procedure:

- Cell Seeding: Seed cells into a 96-well plate at a predetermined optimal density (e.g., 5,000-10,000 cells/well) in 100 μ L of complete medium and incubate for 24 hours.
- Compound Preparation: Prepare a series of dilutions of **Isophysalin G** in complete culture medium from a concentrated DMSO stock. Include a vehicle control (medium with the same final concentration of DMSO as the highest **Isophysalin G** concentration).
- Cell Treatment: Remove the medium from the wells and add 100 μ L of the **Isophysalin G** dilutions or vehicle control.
- Incubation: Incubate the plate for the desired treatment duration (e.g., 24, 48, or 72 hours).
- MTT Addition: Add 20 μ L of MTT solution to each well and incubate for 4 hours at 37°C, allowing viable cells to form formazan crystals.
- Solubilization: Carefully remove the medium and add 150 μ L of solubilization solution to each well to dissolve the formazan crystals. Mix gently on a plate shaker.
- Data Acquisition: Measure the absorbance at 570 nm using a microplate reader.

- **Data Analysis:** Calculate the percentage of cell viability for each concentration relative to the vehicle control. Plot the cell viability against the log of the **Isophysalin G** concentration and determine the IC50 value using non-linear regression analysis.

Protocol 2: Analysis of Apoptosis by Annexin V/Propidium Iodide (PI) Staining

Objective: To quantify the induction of apoptosis by **Isophysalin G**.

Materials:

- Target cancer cell line
- **Isophysalin G**
- Annexin V-FITC/PI Apoptosis Detection Kit
- Binding Buffer
- Flow cytometer

Procedure:

- **Cell Treatment:** Seed cells in 6-well plates and treat with **Isophysalin G** at the desired concentrations (e.g., 1x and 2x the IC50 value) for a specified time (e.g., 24 hours). Include a vehicle-treated control.
- **Cell Harvesting:** Harvest both adherent and floating cells. Centrifuge the cell suspension and wash the cells twice with cold PBS.
- **Staining:** Resuspend the cell pellet in 1X Binding Buffer. Add Annexin V-FITC and PI according to the manufacturer's protocol.
- **Incubation:** Incubate the cells in the dark at room temperature for 15 minutes.
- **Data Acquisition:** Analyze the stained cells by flow cytometry within one hour.

- Data Analysis: Quantify the percentage of cells in each quadrant (viable, early apoptotic, late apoptotic, and necrotic).

Protocol 3: Cell Cycle Analysis by Propidium Iodide (PI) Staining

Objective: To determine the effect of **Isophysalin G** on cell cycle progression.

Materials:

- Target cancer cell line
- **Isophysalin G**
- PBS
- 70% Ethanol (ice-cold)
- Propidium Iodide (PI) staining solution (containing RNase A)
- Flow cytometer

Procedure:

- Cell Treatment: Seed cells and treat with **Isophysalin G** as described for the apoptosis assay.
- Cell Harvesting and Fixation: Harvest the cells, wash with PBS, and fix by dropwise addition of ice-cold 70% ethanol while gently vortexing. Store at -20°C for at least 2 hours.
- Staining: Centrifuge the fixed cells, wash with PBS, and resuspend in PI staining solution.
- Incubation: Incubate for 30 minutes at room temperature in the dark.
- Data Acquisition: Analyze the stained cells by flow cytometry.
- Data Analysis: Analyze the DNA content histograms to determine the percentage of cells in the G0/G1, S, and G2/M phases of the cell cycle.

Visualizing Key Pathways and Workflows

Isophysalin G Signaling Pathways

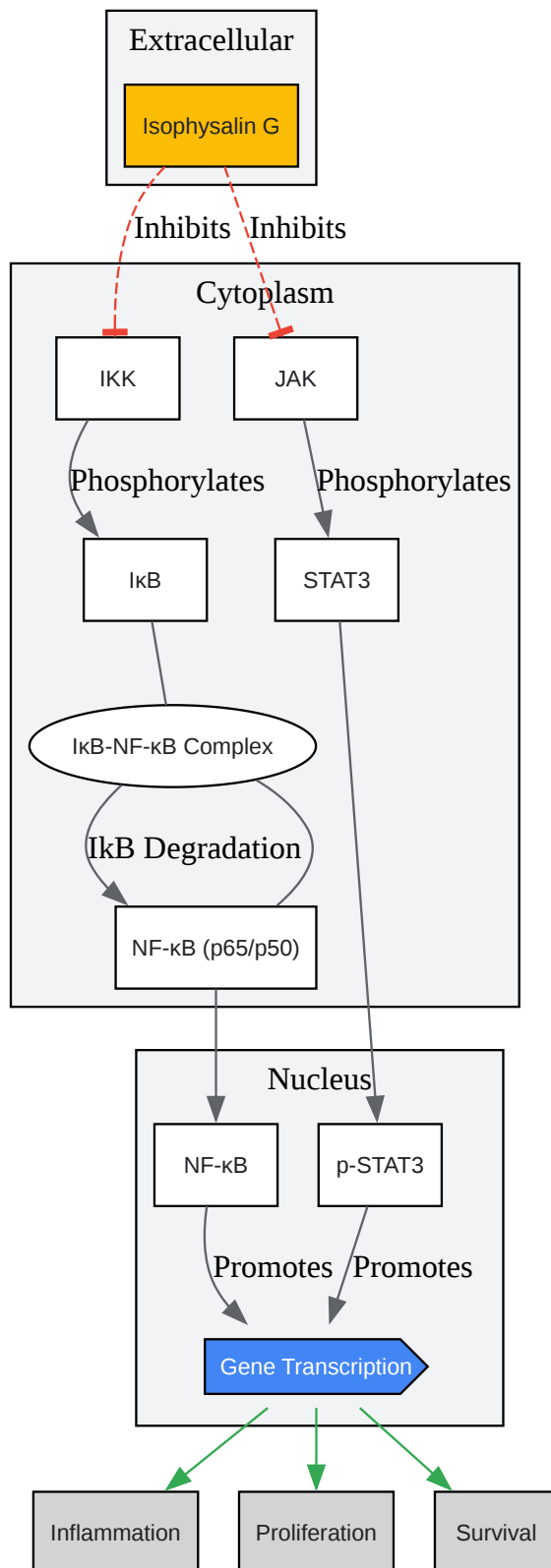

[Click to download full resolution via product page](#)

Caption: **Isophysalin G** inhibits the NF- κ B and STAT3 signaling pathways.

Experimental Workflow for Optimizing Isophysalin G Concentration

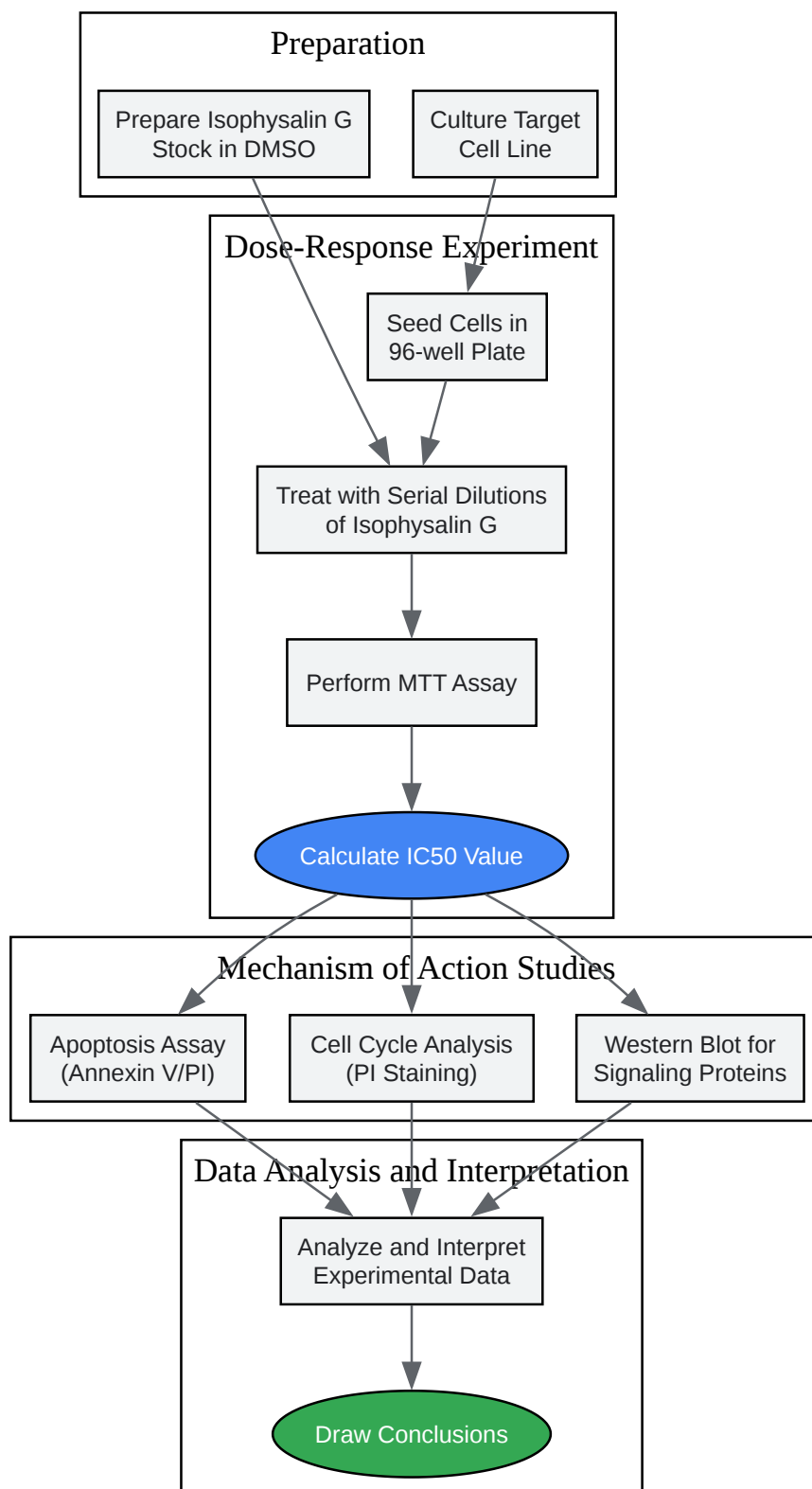

[Click to download full resolution via product page](#)

Caption: Workflow for optimizing **Isophysalin G** concentration.

Need Custom Synthesis?

BenchChem offers custom synthesis for rare earth carbides and specific isotopic labeling.

Email: info@benchchem.com or [Request Quote Online](#).

References

- 1. cdn.gbiosciences.com [cdn.gbiosciences.com]
- 2. [Frontiers | Therapeutic Applications of Physalins: Powerful Natural Weapons](#) [frontiersin.org]
- 3. ar.iijournals.org [ar.iijournals.org]
- 4. ar.iijournals.org [ar.iijournals.org]
- 5. Physalins with anti-inflammatory activity are present in *Physalis alkekengi* var. *franchetii* and can function as Michael reaction acceptors - PubMed [pubmed.ncbi.nlm.nih.gov]
- To cite this document: BenchChem. [Optimizing Isophysalin G Concentration for Cell Treatment: A Technical Support Guide]. BenchChem, [2025]. [Online PDF]. Available at: [<https://www.benchchem.com/product/b12089377#optimizing-isophysalin-g-concentration-for-cell-treatment>]

Disclaimer & Data Validity:

The information provided in this document is for Research Use Only (RUO) and is strictly not intended for diagnostic or therapeutic procedures. While BenchChem strives to provide accurate protocols, we make no warranties, express or implied, regarding the fitness of this product for every specific experimental setup.

Technical Support: The protocols provided are for reference purposes. Unsure if this reagent suits your experiment? [[Contact our Ph.D. Support Team for a compatibility check](#)]

Need Industrial/Bulk Grade? [Request Custom Synthesis Quote](#)

BenchChem

Our mission is to be the trusted global source of essential and advanced chemicals, empowering scientists and researchers to drive progress in science and industry.

Contact

Address: 3281 E Guasti Rd

Ontario, CA 91761, United States

Phone: (601) 213-4426

Email: info@benchchem.com