

# Nimbolide: A Technical Guide to its Discovery and Historical Background

**Author:** BenchChem Technical Support Team. **Date:** December 2025

## Compound of Interest

Compound Name: *Nimbolide*

Cat. No.: *B8084226*

[Get Quote](#)

For Researchers, Scientists, and Drug Development Professionals

## Abstract

**Nimbolide**, a tetranortriterpenoid derived from the neem tree (*Azadirachta indica*), has garnered significant attention within the scientific community for its potent and diverse pharmacological activities, most notably its anticancer properties. This technical guide provides a comprehensive overview of the discovery and historical background of **nimbolide**, detailing its isolation, characterization, and the key scientific milestones in its journey from a natural product to a promising therapeutic lead. The document includes detailed experimental protocols for its extraction and purification, a summary of its physicochemical and biological properties, and a visual representation of its known mechanisms of action through key signaling pathways.

## Discovery and Historical Background

The journey of **nimbolide**'s discovery is rooted in the traditional use of the neem tree in Ayurvedic medicine for various ailments. Scientific investigation into the chemical constituents of neem led to the isolation of a plethora of bioactive compounds, with **nimbolide** emerging as a particularly potent limonoid.

The first definitive isolation and structural elucidation of **nimbolide** was reported in 1967 by D. E. U. Ekong from a Nigerian sample of *Azadirachta indica* leaves.<sup>[1][2][3]</sup> The structure was determined using spectroscopic methods and confirmed by X-ray crystallography, revealing a

complex tetranortriterpenoid skeleton.[4] This seminal work, published in Chemical Communications, laid the foundation for all subsequent research into the biological activities of **nimbolide**.<sup>[1][2][3]</sup>

Following its discovery, research on **nimbolide** was initially focused on its insect antifeedant properties, a common characteristic of neem-derived compounds. However, in the subsequent decades, a growing body of evidence began to highlight its significant cytotoxic and chemopreventive effects, shifting the research focus towards its potential as an anticancer agent. Numerous in vitro and in vivo studies have since demonstrated its efficacy against a wide range of cancer cell lines and tumor models.<sup>[4][5][6][7][8]</sup>

## Physicochemical and Biological Properties

**Nimbolide** is a white to off-white solid with the following physicochemical properties:

Property	Value	Reference(s)
Molecular Formula	C <sub>27</sub> H <sub>30</sub> O <sub>7</sub>	[4]
Molecular Weight	466.5 g/mol	[4]
Melting Point	245-247 °C	[4]
Optical Rotation	[α] <sub>D</sub> +206°	[4]

## Biological Activity:

**Nimbolide** exhibits a broad spectrum of biological activities, with its anticancer effects being the most extensively studied. The table below summarizes its in vitro cytotoxicity against various human cancer cell lines.

Cancer Cell Line	Cancer Type	IC <sub>50</sub> (μM)	Reference(s)
Waldenstrom Macroglobulinemia	Lymphocyte Cancer	0.20	[4]
U937	Leukemia	1.12	[4]
BeWo	Choriocarcinoma	1.19	[4]
HT-29	Colon Cancer	1.25	[4]
PC-3	Prostate Cancer	2.0	[4]
MCF-7	Breast Cancer	2.7 (48h)	[5]
MDA-MB-231	Breast Cancer	3.2 (48h)	[5]
EJ	Bladder Cancer	~3.0	[7]
5637	Bladder Cancer	~3.0	[7]
NE-115	Neuroblastoma	~6.0	[5]
143B	Osteosarcoma	~6.0	[5]
A-549	Lung Cancer	7.59 (48h)	[8]
Du-145	Prostate Cancer	4.97 (48h)	[8]
CEM/ADR5000	Leukemia (Multidrug-Resistant)	0.3	[6]
CCRF-CEM	Leukemia	17.4	[6]

## Experimental Protocols

### Extraction and Purification of Nimbolide

A rapid and efficient method for the extraction and purification of **nimbolide** from neem leaves is Microwave-Assisted Extraction (MAE) followed by Preparative Thin-Layer Chromatography (PTLC).[9][10][11][12]

#### 3.1.1. Microwave-Assisted Extraction (MAE)

- Plant Material: Dried and powdered leaves of *Azadirachta indica*.
- Solvent: Ethanol is reported to be the most efficient solvent for **nimbolide** extraction.[9]
- Optimal MAE Conditions:
  - Solid/Liquid Ratio: 1:16 g/mL[9][11]
  - Microwave Power: 280 W[9][11]
  - Extraction Time: 22 minutes[9][11]
- Procedure:
  - Weigh the powdered neem leaves and place them in the extraction vessel.
  - Add the appropriate volume of ethanol based on the solid/liquid ratio.
  - Subject the mixture to microwave irradiation under the optimized conditions.
  - After extraction, filter the mixture to separate the extract from the solid residue.
  - Concentrate the filtrate under reduced pressure to obtain the crude extract.

### 3.1.2. Purification by Preparative Thin-Layer Chromatography (PTLC)

- Stationary Phase: Silica gel plates.
- Mobile Phase (Eluent): Ethyl acetate/Hexane (4:6 v/v)[9][11]
- Procedure:
  - Dissolve the crude extract in a minimal amount of a suitable solvent (e.g., dichloromethane).
  - Apply the dissolved extract as a band onto the PTLC plate.
  - Develop the plate in a chromatography chamber saturated with the mobile phase.

- After development, visualize the separated bands under UV light.
- Scrape the band corresponding to **nimbolide** from the plate.
- Elute **nimbolide** from the silica gel using a suitable solvent (e.g., ethyl acetate).
- Evaporate the solvent to obtain purified **nimbolide**. This method can yield **nimbolide** with a purity of over 98%.<sup>[9][11]</sup>

## Spectroscopic Characterization

The structure of the purified **nimbolide** should be confirmed by spectroscopic methods.

- Infrared (IR) Spectroscopy:
  - Key carbonyl absorptions are observed at approximately 1770  $\text{cm}^{-1}$  ( $\gamma$ -lactone), 1720  $\text{cm}^{-1}$  ( $\text{CO}_2\text{CH}_3$ ), and 1665  $\text{cm}^{-1}$  (cyclohexenone).<sup>[4]</sup>
- Mass Spectrometry (MS):
  - Electrospray ionization (ESI) mass spectrometry typically shows a protonated molecular ion  $[\text{M}+\text{H}]^+$  at  $m/z$  467.221 and a sodium adduct  $[\text{M}+\text{Na}]^+$  at  $m/z$  489.204.
- Nuclear Magnetic Resonance (NMR) Spectroscopy:
  - $^1\text{H}$ -NMR (400 MHz,  $\text{CDCl}_3$ ,  $\delta$ , ppm): 7.42 (t,  $J = 1.7$  Hz, 1H), 7.32 (t,  $J = 1.7$  Hz, 1H), 6.32 (dd,  $J = 1.8, 0.8$  Hz, 1H), 5.92 (d,  $J = 10.1$  Hz, 1H), 5.51 (s, 1H), 4.25 (s, 1H), 3.70 (s, 3H), 3.48 (d,  $J = 5.2$  Hz, 1H), 2.89 (dd,  $J = 16.5, 5.1$  Hz, 1H), 2.62 (dd,  $J = 16.5, 2.7$  Hz, 1H), 2.45 (m, 1H), 2.25 (m, 1H), 2.15 (m, 1H), 1.95 (m, 1H), 1.42 (s, 3H), 1.25 (s, 3H), 1.15 (s, 3H), 0.95 (d,  $J = 6.9$  Hz, 3H).<sup>[9]</sup>
  - $^{13}\text{C}$ -NMR (100 MHz,  $\text{CDCl}_3$ ,  $\delta$ , ppm): 200.80, 174.97, 172.96, 149.59, 144.78, 143.13, 138.87, 136.42, 131.01, 126.53, 110.32, 88.43, 82.88, 73.43, 51.76, 50.30, 49.47, 47.73, 45.27, 43.65, 41.22, 41.11, 32.14, 18.54, 17.16, 15.15, 12.89.<sup>[9]</sup>

## Mechanism of Action: Key Signaling Pathways

**Nimbolide** exerts its anticancer effects by modulating multiple oncogenic signaling pathways. The following diagrams illustrate its impact on three key pathways: NF- $\kappa$ B, PI3K/Akt, and Wnt/ $\beta$ -catenin.

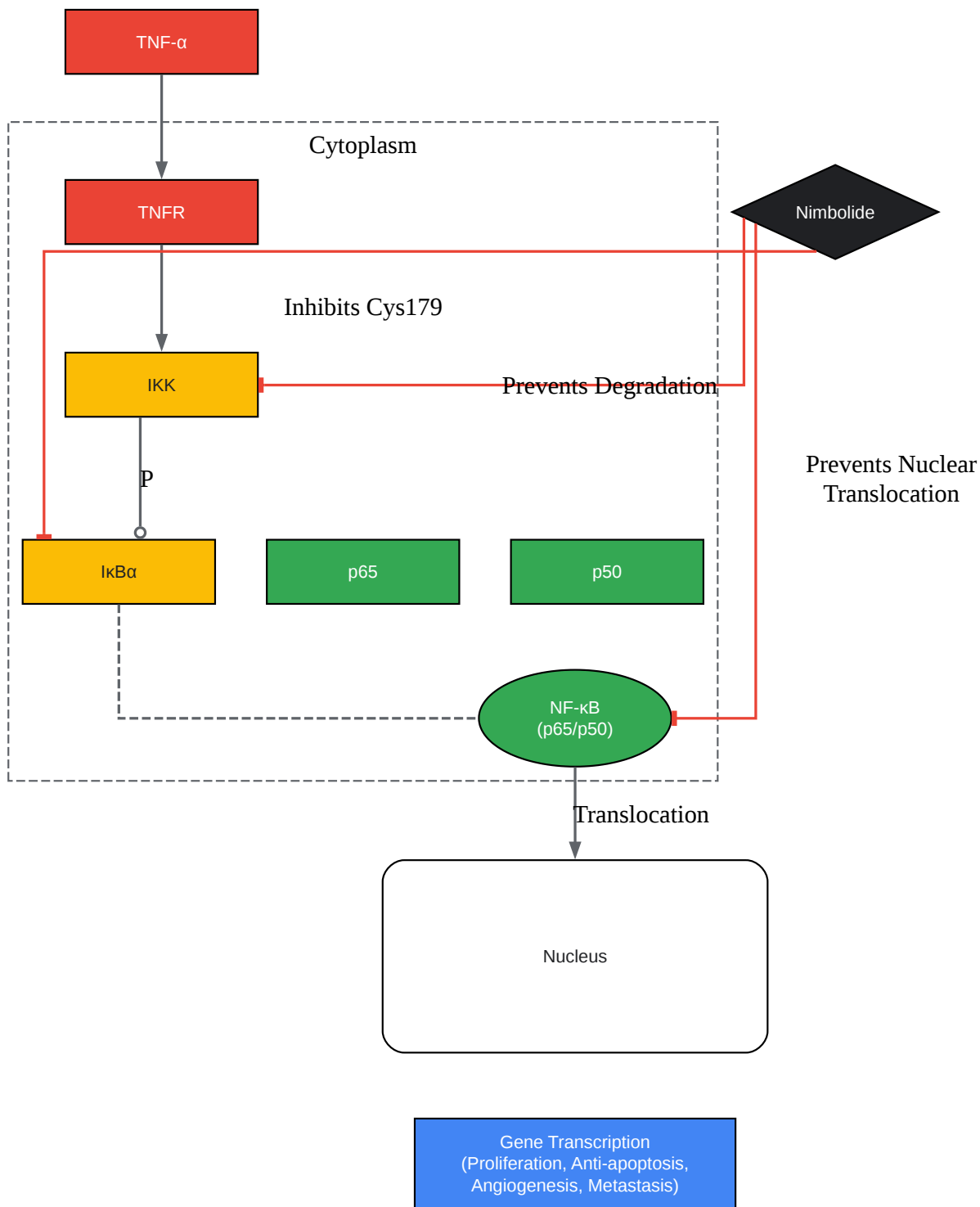

[Click to download full resolution via product page](#)

**Nimbolide's Inhibition of the NF-κB Signaling Pathway.**

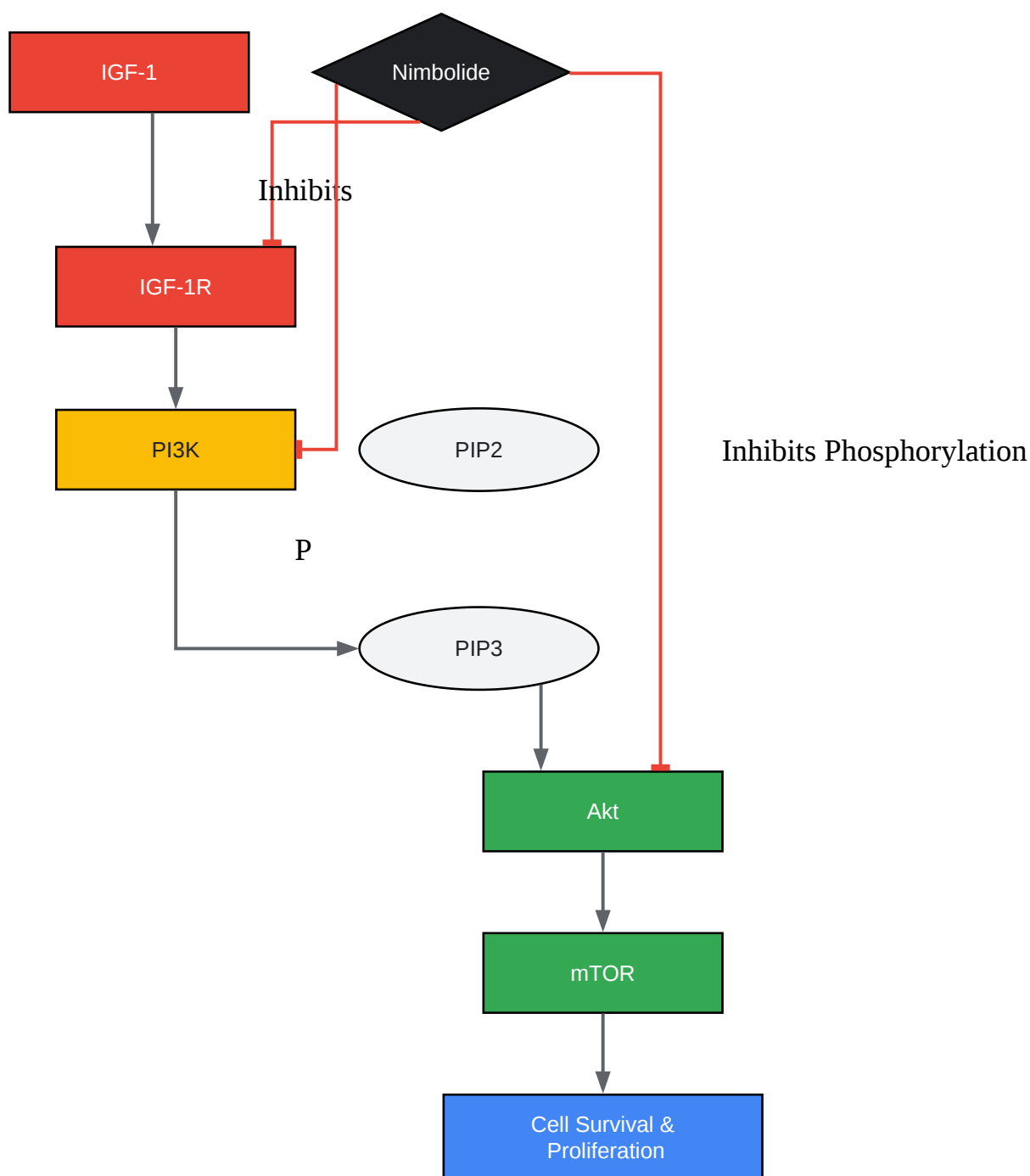

[Click to download full resolution via product page](#)

**Nimbolide's** Inhibition of the PI3K/Akt Signaling Pathway.



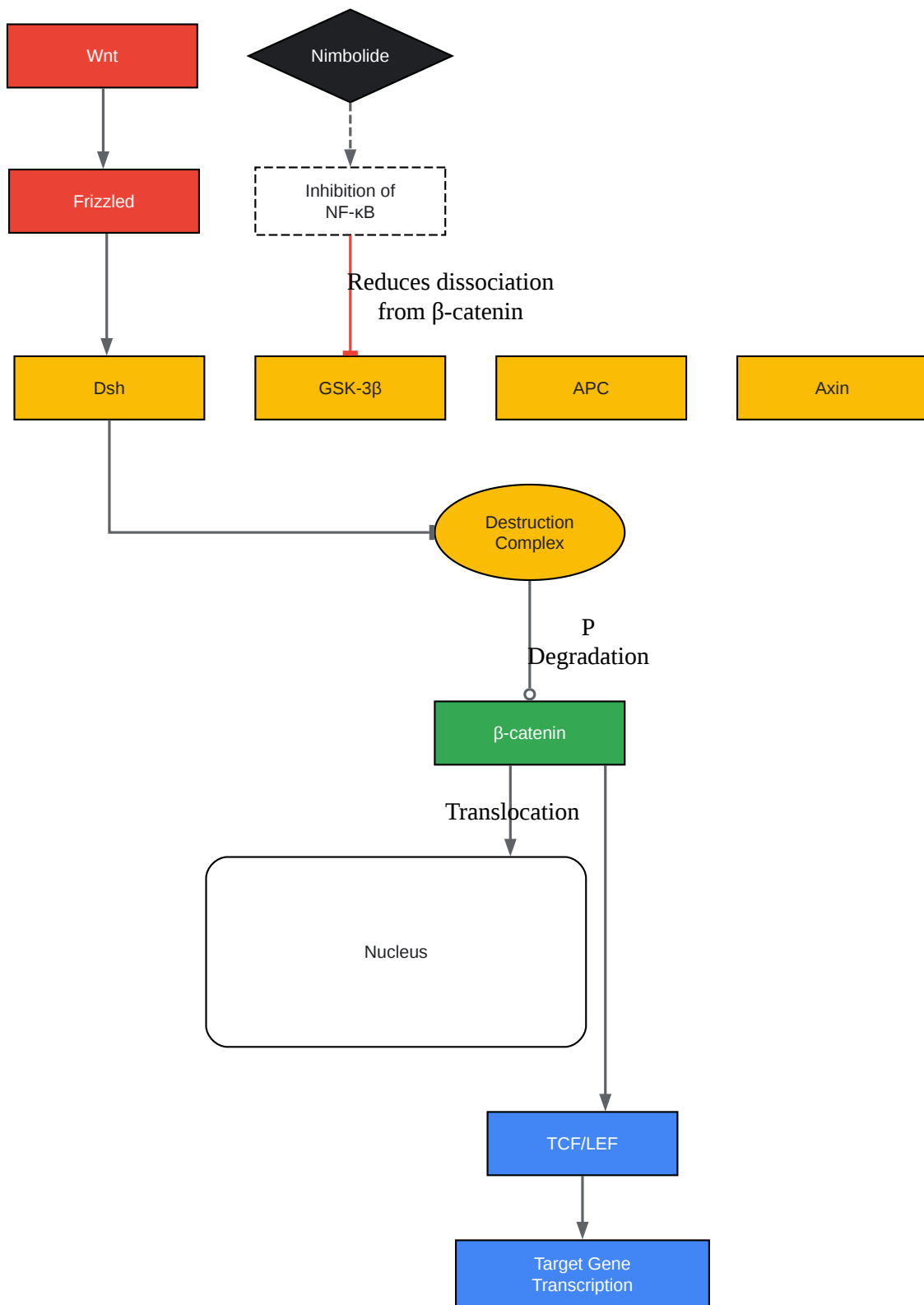

[Click to download full resolution via product page](#)

**Nimbolide's Inhibition of the Wnt/ $\beta$ -catenin Signaling Pathway.**

## Conclusion

Since its initial discovery and characterization over half a century ago, **nimbolide** has transitioned from a compound of interest for its insecticidal properties to a highly promising lead for anticancer drug development. Its multifaceted mechanism of action, targeting key oncogenic signaling pathways, underscores its potential as a therapeutic agent. This technical guide provides a foundational understanding of the historical context, physicochemical properties, and established protocols related to **nimbolide**, serving as a valuable resource for researchers dedicated to advancing this potent natural product towards clinical application. Further research, particularly in the areas of pharmacology, toxicology, and clinical trials, is warranted to fully realize the therapeutic potential of **nimbolide** in the fight against cancer.

### Need Custom Synthesis?

BenchChem offers custom synthesis for rare earth carbides and specific isotopic labeling.

Email: [info@benchchem.com](mailto:info@benchchem.com) or [Request Quote Online](#).

## References

- 1. Nimbolide B and Nimbic Acid B, Phytotoxic Substances in Neem Leaves with Allelopathic Activity - PMC [[pmc.ncbi.nlm.nih.gov](https://pubmed.ncbi.nlm.nih.gov/)]
- 2. Chemistry of the meliacins (limonoids). The structure of nimbolide, a new meliacin from *Azadirachta indica* - Chemical Communications (London) (RSC Publishing) [[pubs.rsc.org](https://pubs.rsc.org/)]
- 3. [semanticscholar.org](https://www.semanticscholar.org/) [[semanticscholar.org](https://www.semanticscholar.org/)]
- 4. Anticancer properties of nimbolide and pharmacokinetic considerations to accelerate its development - PMC [[pmc.ncbi.nlm.nih.gov](https://pubmed.ncbi.nlm.nih.gov/)]
- 5. [researchgate.net](https://www.researchgate.net/) [[researchgate.net](https://www.researchgate.net/)]
- 6. Review on Molecular and Chemopreventive Potential of Nimbolide in Cancer - PMC [[pmc.ncbi.nlm.nih.gov](https://pubmed.ncbi.nlm.nih.gov/)]
- 7. Insights into Nimbolide molecular crosstalk and its anticancer properties | Semantic Scholar [[semanticscholar.org](https://www.semanticscholar.org/)]
- 8. Nimbolide: promising agent for prevention and treatment of chronic diseases (recent update) - PMC [[pmc.ncbi.nlm.nih.gov](https://pubmed.ncbi.nlm.nih.gov/)]

- 9. Microwave-Assisted Improved Extraction and Purification of Anticancer Nimbolide from Azadirachta indica (Neem) Leaves - PMC [pmc.ncbi.nlm.nih.gov]
- 10. researchgate.net [researchgate.net]
- 11. Microwave-Assisted Improved Extraction and Purification of Anticancer Nimbolide from Azadirachta indica (Neem) Leaves [ouci.dntb.gov.ua]
- 12. researchgate.net [researchgate.net]
- To cite this document: BenchChem. [Nimbolide: A Technical Guide to its Discovery and Historical Background]. BenchChem, [2025]. [Online PDF]. Available at: [https://www.benchchem.com/product/b8084226#discovery-and-historical-background-of-nimbolide]

---

### Disclaimer & Data Validity:

The information provided in this document is for Research Use Only (RUO) and is strictly not intended for diagnostic or therapeutic procedures. While BenchChem strives to provide accurate protocols, we make no warranties, express or implied, regarding the fitness of this product for every specific experimental setup.

**Technical Support:** The protocols provided are for reference purposes. Unsure if this reagent suits your experiment? [[Contact our Ph.D. Support Team for a compatibility check](#)]

**Need Industrial/Bulk Grade?** [Request Custom Synthesis Quote](#)

## BenchChem

Our mission is to be the trusted global source of essential and advanced chemicals, empowering scientists and researchers to drive progress in science and industry.

### Contact

Address: 3281 E Guasti Rd  
Ontario, CA 91761, United States  
Phone: (601) 213-4426  
Email: [info@benchchem.com](mailto:info@benchchem.com)