

Molecular docking studies of Hsp90-IN-23 with Hsp90 ATP binding site

Author: BenchChem Technical Support Team. **Date:** December 2025

Compound of Interest

Compound Name: Hsp90-IN-23

Cat. No.: B15588645

[Get Quote](#)

Application Notes and Protocols: Molecular Docking of Hsp90-IN-23

For Researchers, Scientists, and Drug Development Professionals

These application notes provide a comprehensive overview and detailed protocols for the molecular docking of **Hsp90-IN-23**, a potent inhibitor of Heat Shock Protein 90 (Hsp90), with the ATP binding site of the chaperone. This document is intended to guide researchers in computational drug design and analysis of Hsp90 inhibitors.

Introduction

Heat Shock Protein 90 (Hsp90) is a molecular chaperone that plays a critical role in the conformational maturation, stability, and activity of a wide array of client proteins. Many of these client proteins are key components of cellular signaling pathways that are often dysregulated in cancer, such as those involved in cell growth, proliferation, and survival. The N-terminal domain of Hsp90 contains a highly conserved ATP-binding pocket that is essential for its chaperone function. Inhibition of this site leads to the degradation of Hsp90 client proteins, making it an attractive target for cancer therapy.

Hsp90-IN-23 is a small molecule inhibitor of Hsp90 with a reported IC₅₀ of 9 nM, demonstrating its high potency.[1] Molecular docking is a computational technique used to predict the preferred orientation of one molecule to a second when bound to each other to form

a stable complex. These studies are instrumental in understanding the binding mode of inhibitors like **Hsp90-IN-23** at the molecular level and in the rational design of new, more effective anticancer agents.

Quantitative Data Summary

The following table summarizes the available quantitative data for the interaction of **Hsp90-IN-23** with Hsp90.

Compound	Target	Method	Value	Reference
Hsp90-IN-23	Hsp90	In vitro inhibition assay	IC50 = 9 nM	[1]
Hsp90-IN-23	Hsp90	Molecular Docking (Predicted)	-	*

*Note: Specific docking scores or binding energies for **Hsp90-IN-23** were not found in the reviewed literature. A typical docking score for a potent inhibitor in the Hsp90 ATP binding site would be in the range of -9 to -12 kcal/mol, as predicted by software like AutoDock Vina.

Signaling Pathway of Hsp90 and its Client Proteins

Hsp90 is a central hub in cellular signaling, ensuring the proper folding and function of numerous client proteins, many of which are oncoproteins. Inhibition of Hsp90 disrupts these pathways, leading to cell cycle arrest and apoptosis.

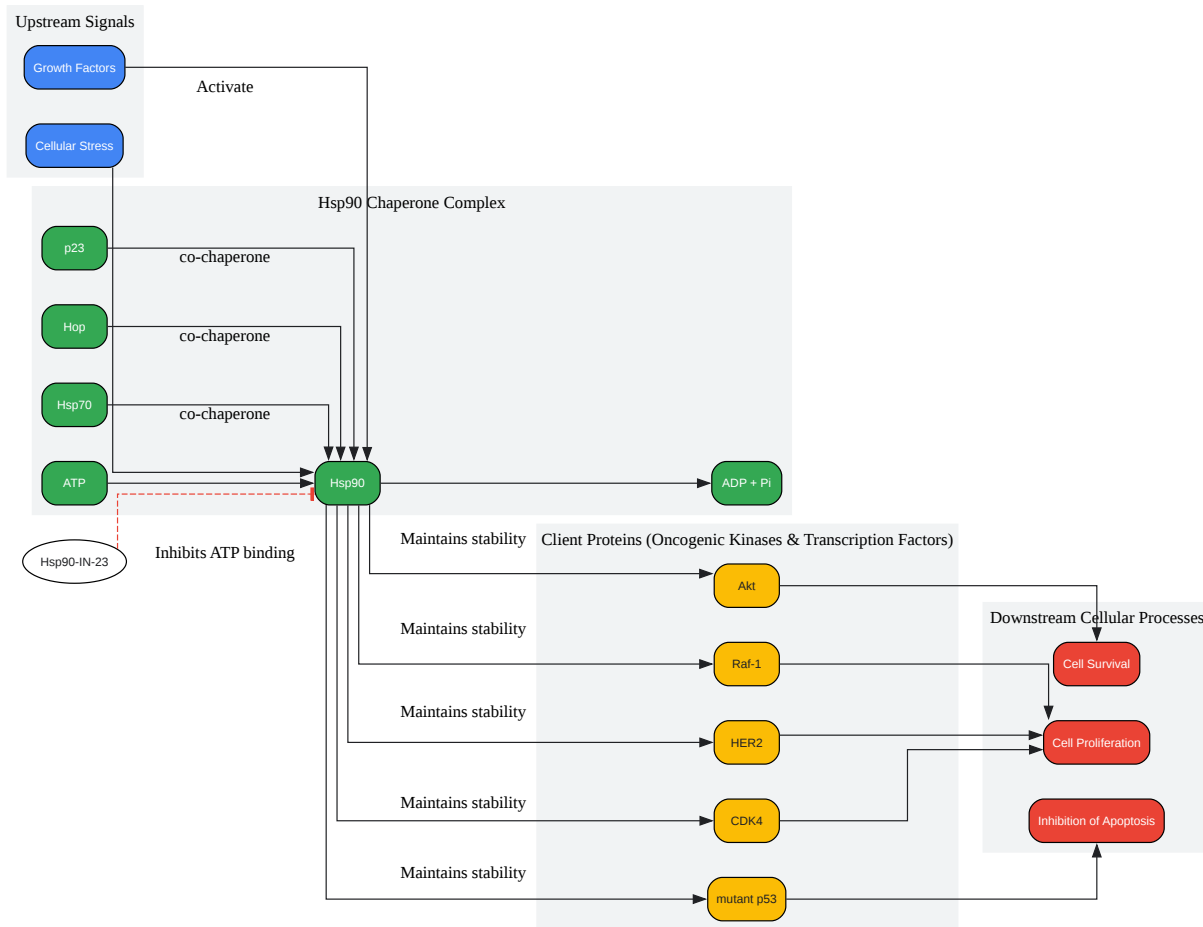

[Click to download full resolution via product page](#)

Caption: Hsp90 signaling pathway and client protein interactions.

Experimental Protocols

This section provides a detailed protocol for performing a molecular docking study of **Hsp90-IN-23** with the ATP binding site of human Hsp90 using AutoDock Vina.

Workflow for Molecular Docking of Hsp90-IN-23

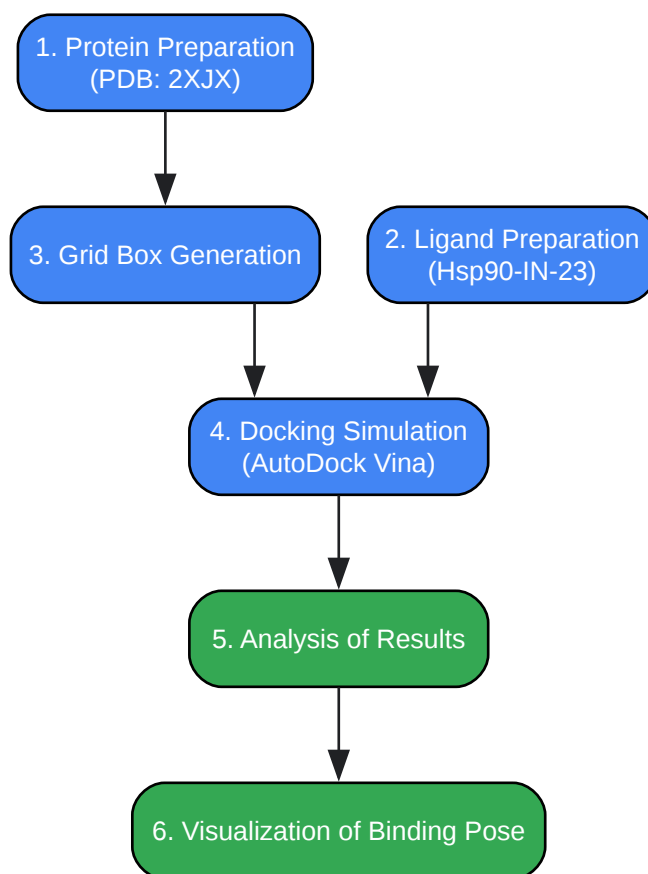

[Click to download full resolution via product page](#)

Caption: Experimental workflow for molecular docking.

Software and Resource Requirements

- Molecular Graphics Laboratory (MGL) Tools: For preparing protein and ligand files.
- AutoDock Vina: For performing the docking simulation.
- PyMOL or Chimera: For visualization and analysis of results.

- Protein Data Bank (PDB): To obtain the crystal structure of Hsp90.
- PubChem or other chemical database: To obtain the structure of **Hsp90-IN-23**.

Detailed Protocol

Step 2.1: Protein Preparation

- Obtain Hsp90 Structure: Download the crystal structure of human Hsp90 from the PDB. For this protocol, we will use PDB ID: 2XJX. This structure contains a co-crystallized inhibitor in the ATP-binding site, which helps in defining the binding pocket.
- Clean the Protein: Open the PDB file in a molecular viewer (e.g., PyMOL). Remove water molecules, co-solvents, and any ligands or ions that are not relevant to the binding site. For 2XJX, remove the co-crystallized inhibitor.
- Prepare the Receptor for Docking using MGL-Tools (AutoDockTools):
 - Load the cleaned PDB file into AutoDockTools.
 - Add polar hydrogens to the protein.
 - Compute Gasteiger charges.
 - Merge non-polar hydrogens.
 - Save the prepared protein in PDBQT format (e.g., hsp90.pdbqt).

Step 2.2: Ligand Preparation

- Obtain **Hsp90-IN-23** Structure: The chemical structure of **Hsp90-IN-23** can be obtained from chemical databases like PubChem or commercial vendor websites. Its molecular formula is C₂₄H₂₄N₄O₄.
- Generate 3D Conformation: Use a chemical drawing tool (e.g., ChemDraw) to draw the 2D structure and then convert it to a 3D structure.
- Prepare the Ligand for Docking using MGL-Tools (AutoDockTools):

- Load the 3D structure of **Hsp90-IN-23** into AutoDockTools.
- Detect the root of the molecule.
- Set the number of rotatable bonds (torsions).
- Save the prepared ligand in PDBQT format (e.g., hsp90_in_23.pdbqt).

Step 2.3: Grid Box Generation

The grid box defines the search space for the docking simulation. It should encompass the entire ATP binding site of Hsp90.

- **Define the Binding Site:** In AutoDockTools, with the hsp90.pdbqt file loaded, use the coordinates of the co-crystallized ligand from the original PDB file (2XJX) to center the grid box.
- **Set Grid Box Dimensions:** A typical grid box size for the Hsp90 ATP binding site is 25 x 25 x 25 Å with a spacing of 1.0 Å. Ensure the box is large enough to allow the ligand to move and rotate freely within the binding pocket.
- **Create a Configuration File:** Create a text file (e.g., conf.txt) and specify the coordinates of the grid box center and its dimensions.

Step 2.4: Running the Docking Simulation

- **Execute AutoDock Vina:** Open a terminal or command prompt and run the following command:
- **Output:** AutoDock Vina will generate an output file (docking_results.pdbqt) containing the predicted binding poses and their corresponding binding affinities (in kcal/mol). A log file (docking_log.txt) will also be created.

Step 2.5: Analysis and Visualization of Results

- **Analyze Binding Affinity:** The output file will list the binding poses in order of their binding affinity. The top-ranked pose with the lowest binding energy is considered the most favorable.

- Visualize the Binding Pose: Load the hsp90.pdbqt and docking_results.pdbqt files into a molecular visualization tool like PyMOL or Chimera.
- Examine Interactions: Analyze the interactions between **Hsp90-IN-23** and the amino acid residues in the Hsp90 ATP binding pocket. Identify key hydrogen bonds, hydrophobic interactions, and other non-covalent interactions that contribute to the binding affinity.

Conclusion

This document provides a framework for conducting molecular docking studies of **Hsp90-IN-23** with the Hsp90 ATP binding site. The provided protocols and diagrams are intended to facilitate research into the mechanism of action of Hsp90 inhibitors and to aid in the discovery of novel anticancer therapeutics. The high potency of **Hsp90-IN-23** makes it an important compound for further computational and experimental investigation.

Need Custom Synthesis?

BenchChem offers custom synthesis for rare earth carbides and specific isotopic labeling.

Email: info@benchchem.com or [Request Quote Online](#).

References

- 1. medchemexpress.com [medchemexpress.com]
- To cite this document: BenchChem. [Molecular docking studies of Hsp90-IN-23 with Hsp90 ATP binding site]. BenchChem, [2025]. [Online PDF]. Available at: [https://www.benchchem.com/product/b15588645#molecular-docking-studies-of-hsp90-in-23-with-hsp90-atp-binding-site]

Disclaimer & Data Validity:

The information provided in this document is for Research Use Only (RUO) and is strictly not intended for diagnostic or therapeutic procedures. While BenchChem strives to provide accurate protocols, we make no warranties, express or implied, regarding the fitness of this product for every specific experimental setup.

Technical Support: The protocols provided are for reference purposes. Unsure if this reagent suits your experiment? [[Contact our Ph.D. Support Team for a compatibility check](#)]

Need Industrial/Bulk Grade? [Request Custom Synthesis Quote](#)

BenchChem

Our mission is to be the trusted global source of essential and advanced chemicals, empowering scientists and researchers to drive progress in science and industry.

Contact

Address: 3281 E Guasti Rd

Ontario, CA 91761, United States

Phone: (601) 213-4426

Email: info@benchchem.com