

Methodologies for Studying AZD-1305's Proarrhythmic Potential: Application Notes and Protocols

Author: BenchChem Technical Support Team. **Date:** December 2025

Compound of Interest

Compound Name: AZD-1305

Cat. No.: B605743

[Get Quote](#)

For Researchers, Scientists, and Drug Development Professionals

This document provides detailed application notes and protocols for assessing the proarrhythmic potential of **AZD-1305**, an investigational antiarrhythmic agent. The methodologies outlined are based on established in vitro and in vivo models and are intended to guide researchers in the comprehensive evaluation of the electrophysiological effects of this compound.

Introduction

AZD-1305 is a compound with combined ion channel-blocking properties, primarily targeting the rapid component of the delayed rectifier potassium current (IKr), the L-type calcium current (ICaL), and the inward sodium current (INa)[1][2][3]. Its development has been aimed at the management of atrial fibrillation[2][4][5]. A critical aspect of the safety assessment for any antiarrhythmic agent is its potential to induce arrhythmias, a property known as proarrhythmia. This document details the key experimental methodologies to thoroughly investigate the proarrhythmic risk of **AZD-1305**.

In Vitro Methodologies

In vitro assays are fundamental for characterizing the effects of **AZD-1305** on individual cardiac ion channels and its integrated effect on the cardiac action potential.

Ion Channel Assays using Whole-Cell Patch-Clamp Electrophysiology

The whole-cell patch-clamp technique is the gold standard for assessing the potency and kinetics of ion channel blockade[2].

Objective: To quantify the concentration-dependent block of key cardiac ion channels (hERG, Nav1.5, Cav1.2) by **AZD-1305**.

Experimental Protocol:

- Cell Preparation: Utilize human embryonic kidney (HEK-293) cells or Chinese hamster ovary (CHO) cells stably transfected with the genes encoding the alpha subunits of the target ion channels (e.g., KCNH2 for hERG, SCN5A for Nav1.5, CACNA1C for Cav1.2).
- Electrophysiological Recording:
 - Maintain cells in a bath solution (e.g., Tyrode's solution) at a physiological temperature (e.g., 35-37°C).
 - Use borosilicate glass micropipettes with a resistance of 2-5 MΩ when filled with the appropriate internal solution.
 - Establish a whole-cell recording configuration.
 - Apply specific voltage-clamp protocols to elicit and isolate the target ionic currents.
 - For hERG (IKr), a typical protocol involves a depolarizing step to +20 mV followed by a repolarizing step to -50 mV to elicit the characteristic tail current.
 - For Nav1.5 (INa), use a series of depolarizing steps from a holding potential of -120 mV.
 - For Cav1.2 (ICaL), apply depolarizing steps from a holding potential of -80 mV.
- Drug Application: Perfuse the cells with increasing concentrations of **AZD-1305**. Allow for steady-state block to be reached at each concentration.

- **Data Analysis:** Measure the peak current amplitude for INa and ICaL, and the peak tail current for IKr in the presence and absence of **AZD-1305**. Calculate the percentage of current inhibition at each concentration and fit the data to a Hill equation to determine the IC50 value.

Data Presentation:

Ion Channel	AZD-1305 IC50 (μM)
hERG (IKr)	Data to be populated from experimental findings
Nav1.5 (peak INa)	Data to be populated from experimental findings
Nav1.5 (late INa)	Data to be populated from experimental findings
Cav1.2 (ICaL)	Data to be populated from experimental findings

Cardiac Action Potential Recordings in Isolated Preparations

These experiments assess the integrated effect of **AZD-1305** on the action potential morphology and duration.

Objective: To determine the effect of **AZD-1305** on action potential duration (APD), maximum upstroke velocity (V_{max}), and the induction of early afterdepolarizations (EADs) in isolated cardiac tissues.

Experimental Protocol:

- **Tissue Preparation:** Isolate preparations such as canine pulmonary vein sleeves or arterially perfused ventricular wedge preparations^{[3][6]}.
- **Electrophysiological Recording:**
 - Superfuse the tissue with oxygenated Tyrode's solution at a physiological temperature.
 - Use sharp glass microelectrodes filled with 3 M KCl to impale cardiac myocytes and record intracellular action potentials.

- Pace the preparation at different cycle lengths (e.g., 1000 ms, 300 ms, 200 ms) to assess rate-dependent effects[7].
- Drug Application: Superfuse the tissue with increasing concentrations of **AZD-1305**.
- Data Analysis: Measure the following parameters at each concentration and pacing cycle length:
 - Action Potential Duration at 90% repolarization (APD90).
 - Maximum upstroke velocity (V_{max}), an indicator of sodium channel block.
 - Action Potential Amplitude (APA).
 - Presence and characteristics of EADs.

Data Presentation:

Parameter	Control	AZD-1305 (1 μ M)	AZD-1305 (3 μ M)	AZD-1305 (10 μ M)
APD90 (ms) at 1 Hz	Value	Value	Value	Value
V_{max} (V/s) at 1 Hz	Value	Value	Value	Value
EAD Incidence (%)	Value	Value	Value	Value

Table adapted from data that would be generated in such an experiment.

In Vivo Methodologies

In vivo studies are crucial for evaluating the proarrhythmic potential of **AZD-1305** in a whole-animal system, taking into account pharmacokinetics and autonomic influences.

Anesthetized Dog Model

This model is used to assess the effects of **AZD-1305** on cardiac electrophysiology and its potential to suppress atrial fibrillation.

Objective: To evaluate the in vivo effects of **AZD-1305** on atrial and ventricular refractory periods, action potential duration, and conduction time.

Experimental Protocol:

- **Animal Preparation:** Anesthetize mongrel dogs of either sex. Introduce catheters for drug administration, blood pressure monitoring, and intracardiac recordings.
- **Electrophysiological Measurements:** Record surface ECG and intracardiac electrograms. Measure parameters such as heart rate, blood pressure, action potential duration, effective refractory period (ERP), and conduction time in both atria and ventricles[4][5].
- **Drug Administration:** Administer **AZD-1305** intravenously at escalating doses.
- **Data Analysis:** Compare the electrophysiological parameters before and after drug administration. Note any atrial-selective effects.

Data Presentation:

Parameter	Pre-AZD-1305	Post-AZD-1305 (Dose X)
Atrial ERP (ms)	Value	Value
Ventricular ERP (ms)	Value	Value
Atrial APD90 (ms)	Value	Value
Ventricular APD90 (ms)	Value	Value

Table adapted from data that would be generated in such an experiment.

Methoxamine-Sensitized Rabbit Model

This is a sensitive model for detecting the potential of a drug to induce Torsades de Pointes (TdP)[8].

Objective: To assess the propensity of **AZD-1305** to induce TdP in a sensitized animal model and compare it to a known TdP-inducing drug like dofetilide.

Experimental Protocol:

- **Animal Preparation:** Anesthetize rabbits and administer the α -agonist methoxamine to induce bradycardia and sensitize the heart to proarrhythmic events.
- **ECG Monitoring:** Continuously monitor the ECG for changes in QT interval, T-wave morphology, and the occurrence of ventricular arrhythmias, including TdP.
- **Drug Infusion:** Infuse **AZD-1305** intravenously at a constant rate. In a separate group of animals, infuse dofetilide as a positive control.
- **Data Analysis:** Measure the QT interval and beat-to-beat variability of the QT interval (short-term variability, STV). Record the incidence of TdP. Compare the effects of **AZD-1305** with dofetilide[2].

Data Presentation:

Parameter	Vehicle Control	AZD-1305	Dofetilide
QT Interval Prolongation (ms)	Value	Value	Value
Short-Term Variability (ms)	Value	Value	Value
TdP Incidence (%)	Value	Value	Value

Table based on findings from comparative studies.[2]

Chronic Atrioventricular (AV) Block Dog Model

This model exhibits enhanced susceptibility to drug-induced TdP and is considered a highly sensitive model for proarrhythmia assessment[9][10].

Objective: To evaluate the proarrhythmic potential of **AZD-1305** in a remodeled heart model with reduced repolarization reserve.

Experimental Protocol:

- Model Creation: Induce complete AV block in dogs via catheter ablation. Allow for a period of remodeling (e.g., >2 weeks).
- Electrophysiological Studies: In anesthetized AV block dogs, administer **AZD-1305** and a positive control (e.g., dofetilide) on separate occasions.
- Data Collection: Record ECG and left ventricular monophasic action potentials. Measure QT interval and beat-to-beat variability of monophasic action potential duration.
- Data Analysis: Compare the incidence of TdP and the changes in repolarization instability between **AZD-1305** and the positive control[9].

Data Presentation:

Parameter	Pre-Drug	AZD-1305	Dofetilide
QT Interval (ms)	Value	Value	Value
Beat-to-beat Variability of LV-MAPD (ms)	Value	Value	Value
TdP Incidence (%)	0	Value	Value

Table based on findings from comparative studies in remodeled hearts.[9]

Signaling Pathways and Experimental Workflows

The following diagrams illustrate the mechanism of action of **AZD-1305** and the general workflows for its proarrhythmia assessment.

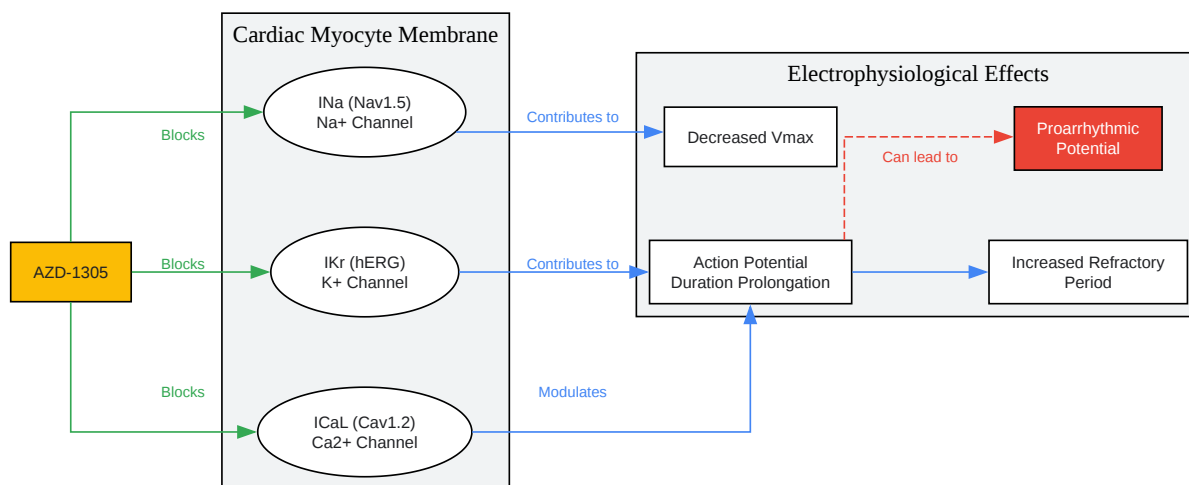

[Click to download full resolution via product page](#)

Caption: Mechanism of action of **AZD-1305** on cardiac ion channels.

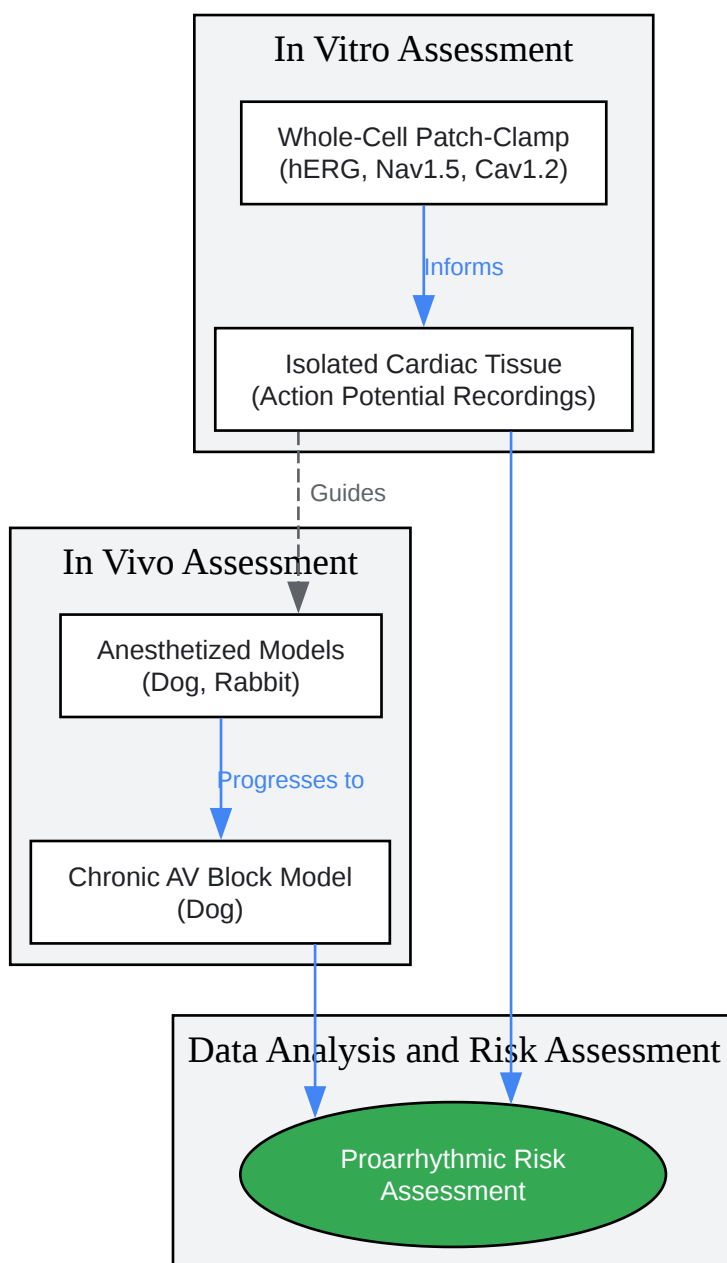

[Click to download full resolution via product page](#)

Caption: General workflow for assessing the proarrhythmic potential of **AZD-1305**.

Conclusion

A comprehensive assessment of the proarrhythmic potential of **AZD-1305** requires a multi-faceted approach. The methodologies described herein, from in vitro ion channel screening to in vivo studies in sensitive and remodeled animal models, provide a robust framework for

characterizing its electrophysiological profile. The atrial-predominant effects of **AZD-1305**, coupled with its combined ion channel blocking properties, suggest a complex proarrhythmic profile that warrants careful and thorough investigation[1][4]. The data generated from these studies are essential for a comprehensive risk-benefit analysis in the development of **AZD-1305** as a potential antiarrhythmic therapy.

Need Custom Synthesis?

BenchChem offers custom synthesis for rare earth carbides and specific isotopic labeling.

Email: info@benchchem.com or [Request Quote Online](#).

References

- 1. AZD1305 - Wikipedia [en.wikipedia.org]
- 2. Assessment of the ion channel-blocking profile of the novel combined ion channel blocker AZD1305 and its proarrhythmic potential versus dofetilide in the methoxamine-sensitized rabbit in vivo - PubMed [pubmed.ncbi.nlm.nih.gov]
- 3. Electrophysiologic and Antiarrhythmic Effects of AZD1305 in Canine Pulmonary Vein Sleeves - PMC [pmc.ncbi.nlm.nih.gov]
- 4. AZD1305 exerts atrial predominant electrophysiological actions and is effective in suppressing atrial fibrillation and preventing its reinduction in the dog - PubMed [pubmed.ncbi.nlm.nih.gov]
- 5. AZD1305 Exerts Atrial-Predominant Electrophysiological Actions and Is Effective in Suppressing Atrial Fibrillation and Preventing Its Re-induction in the Dog - PMC [pmc.ncbi.nlm.nih.gov]
- 6. In vitro models of proarrhythmia - PMC [pmc.ncbi.nlm.nih.gov]
- 7. researchgate.net [researchgate.net]
- 8. researchgate.net [researchgate.net]
- 9. Reduced ventricular proarrhythmic potential of the novel combined ion-channel blocker AZD1305 versus dofetilide in dogs with remodeled hearts - PubMed [pubmed.ncbi.nlm.nih.gov]
- 10. Sensitive and reliable proarrhythmia in vivo animal models for predicting drug-induced torsades de pointes in patients with remodelled hearts - PMC [pmc.ncbi.nlm.nih.gov]

- To cite this document: BenchChem. [Methodologies for Studying AZD-1305's Proarrhythmic Potential: Application Notes and Protocols]. BenchChem, [2025]. [Online PDF]. Available at: [<https://www.benchchem.com/product/b605743#methodologies-for-studying-azd-1305-s-proarrhythmic-potential>]

Disclaimer & Data Validity:

The information provided in this document is for Research Use Only (RUO) and is strictly not intended for diagnostic or therapeutic procedures. While BenchChem strives to provide accurate protocols, we make no warranties, express or implied, regarding the fitness of this product for every specific experimental setup.

Technical Support: The protocols provided are for reference purposes. Unsure if this reagent suits your experiment? [[Contact our Ph.D. Support Team for a compatibility check](#)]

Need Industrial/Bulk Grade? [Request Custom Synthesis Quote](#)

BenchChem

Our mission is to be the trusted global source of essential and advanced chemicals, empowering scientists and researchers to drive progress in science and industry.

Contact

Address: 3281 E Guasti Rd

Ontario, CA 91761, United States

Phone: (601) 213-4426

Email: info@benchchem.com