

# Lanosol and its Role in Red Algae Chemical Ecology: A Technical Guide

**Author:** BenchChem Technical Support Team. **Date:** December 2025

## Compound of Interest

Compound Name: *Lanosol*

Cat. No.: *B1195854*

[Get Quote](#)

For Researchers, Scientists, and Drug Development Professionals

## Executive Summary

**Lanosol** (2,3-dibromo-4,5-dihydroxybenzyl alcohol) is a brominated phenolic compound produced by various species of red algae (Rhodophyta), particularly those belonging to the family Rhodomelaceae. This secondary metabolite plays a crucial role in the chemical defense mechanisms of these marine organisms, exhibiting a broad spectrum of biological activities, including potent antimicrobial and antifouling properties. Its hydrophobic nature is believed to facilitate the disruption of microbial cell membranes, leading to bacteriostatic and fungistatic effects. This technical guide provides a comprehensive overview of **lanosol**, including its biosynthesis, methods for its extraction and purification, quantitative data on its biological activities, and a discussion of its known and proposed mechanisms of action.

## Introduction to Lanosol

Red algae synthesize a diverse array of halogenated secondary metabolites, with bromophenols being a prominent class of compounds. Among these, **lanosol** and its derivatives are of significant interest due to their pronounced biological activities. These compounds are believed to be a key component of the alga's defense against microbial colonization and herbivory. The presence of bromine atoms and hydroxyl groups on the aromatic ring is critical for the bioactivity of these molecules.

## Biosynthesis of Lanosol

The complete biosynthetic pathway of **lanosol** in red algae has not been fully elucidated and remains an active area of research. However, it is widely accepted that the pathway originates from the shikimate pathway, with L-tyrosine serving as the primary precursor. The key enzymatic step involves the action of vanadium-dependent haloperoxidases, specifically bromoperoxidases, which catalyze the electrophilic bromination of the aromatic ring.

The proposed biosynthetic pathway can be summarized as follows:

- **Precursor Synthesis:** The pathway begins with the synthesis of L-tyrosine via the shikimate pathway.
- **Conversion to p-hydroxybenzoic acid derivatives:** Tyrosine is likely converted to various p-hydroxybenzoic acid intermediates.
- **Enzymatic Bromination:** Vanadium-dependent bromoperoxidases, in the presence of bromide ions and hydrogen peroxide, catalyze the bromination of the phenolic ring at specific positions. The regioselectivity of this bromination is a key step in determining the final structure of the bromophenol.
- **Further Enzymatic Modifications:** A series of subsequent enzymatic reactions, including hydroxylations, reductions, and etherifications, are thought to lead to the formation of **lanosol** and its various derivatives.

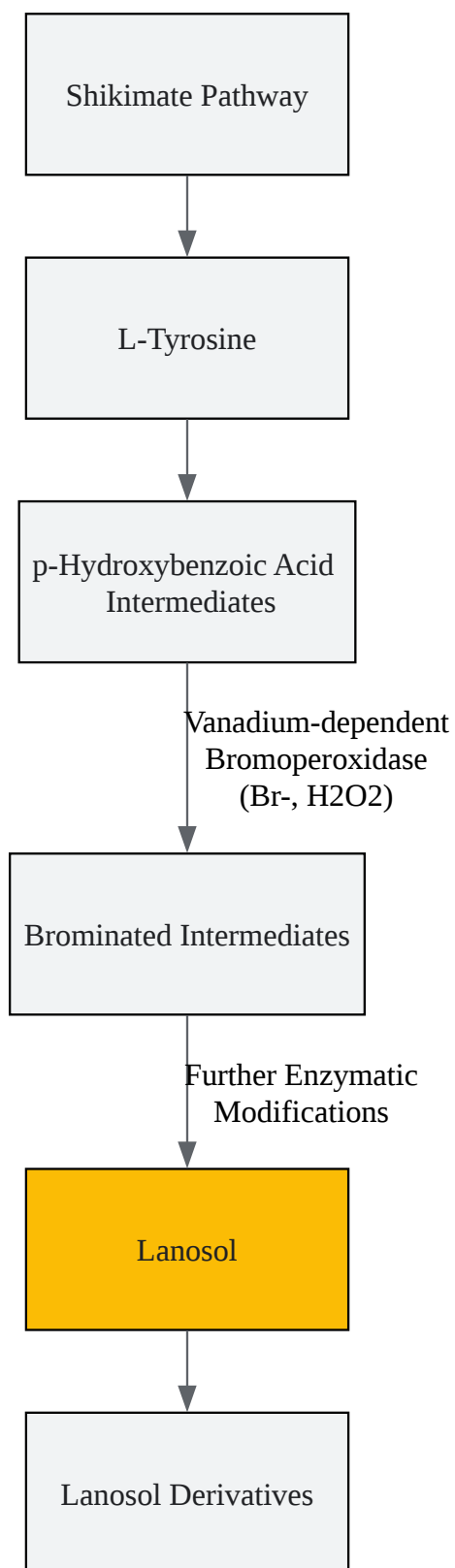

[Click to download full resolution via product page](#)

**Figure 1.** Proposed biosynthetic pathway of **Lanosol** in red algae.

## Experimental Protocols

### Extraction of Lanosol from Red Algae

The following is a composite protocol based on methodologies described in the literature for the extraction of bromophenols from red algae such as *Osmundaria serrata* and other members of the Rhodomelaceae family.

#### Materials:

- Fresh or freeze-dried red algae (e.g., *Osmundaria serrata*)
- Methanol (MeOH), analytical grade
- Ethyl acetate (EtOAc), analytical grade
- Dichloromethane (CH<sub>2</sub>Cl<sub>2</sub>), analytical grade
- Hexane, analytical grade
- Grinder or blender
- Filter paper (Whatman No. 1 or equivalent)
- Rotary evaporator
- Separatory funnel

#### Procedure:

- **Sample Preparation:** Thoroughly wash the fresh algal material with seawater and then freshwater to remove epiphytes and salts. Air-dry the algae in a well-ventilated area or freeze-dry to a constant weight. Grind the dried material into a fine powder.
- **Initial Extraction:**
  - Macerate the powdered algae (100 g) in methanol (500 mL) at room temperature for 24-48 hours with occasional stirring.

- Filter the extract through filter paper.
- Repeat the extraction process with the algal residue two more times with fresh methanol.
- Combine the methanolic extracts and concentrate under reduced pressure using a rotary evaporator at a temperature not exceeding 40°C to obtain a crude methanolic extract.
- Solvent Partitioning:
  - Resuspend the crude methanolic extract in a mixture of methanol and water (e.g., 9:1 v/v).
  - Perform a liquid-liquid partitioning of the aqueous methanol extract against n-hexane to remove nonpolar compounds like lipids and pigments. Repeat this step three times.
  - Subsequently, partition the aqueous methanol phase against dichloromethane or ethyl acetate to extract compounds of medium polarity, including **lanosol**. Repeat this step three times.
  - Combine the organic (dichloromethane or ethyl acetate) fractions and dry over anhydrous sodium sulfate.
  - Concentrate the dried organic extract using a rotary evaporator to yield the enriched bromophenol fraction.

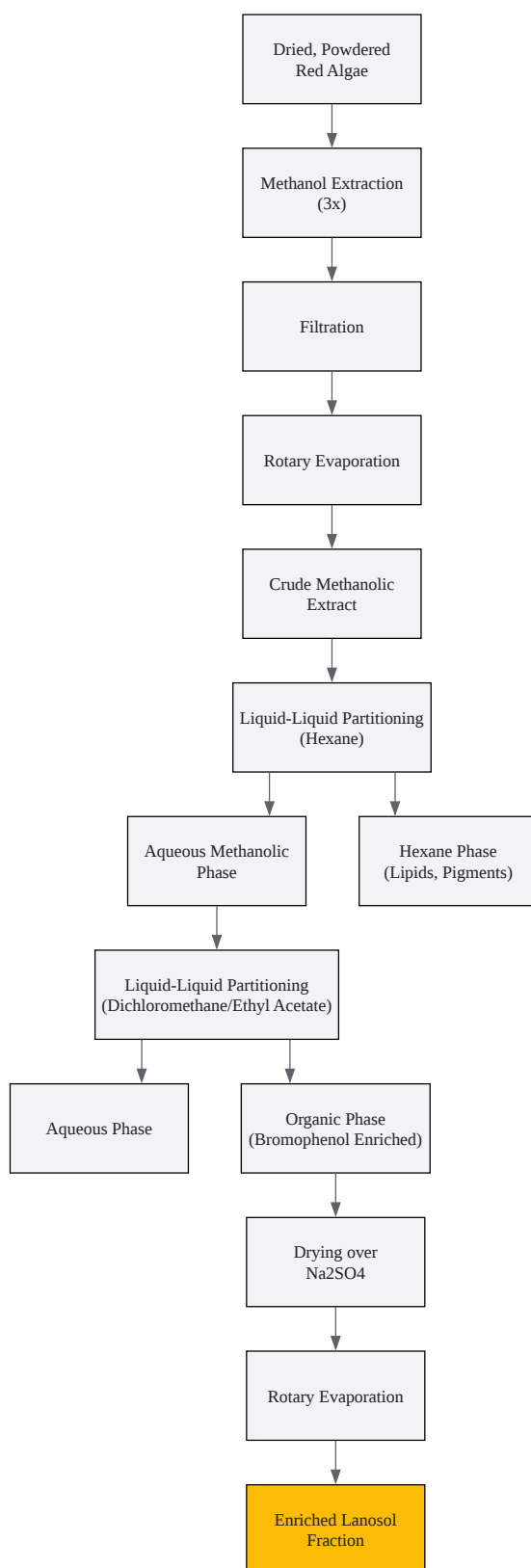

[Click to download full resolution via product page](#)

**Figure 2.** General workflow for the extraction of **Lanosol**.

## Purification of Lanosol

### Materials:

- Enriched **lanosol** fraction from the extraction step
- Silica gel (for column chromatography, 70-230 mesh)
- Sephadex LH-20
- Solvents for chromatography (e.g., n-hexane, ethyl acetate, methanol, ethanol)
- Thin-layer chromatography (TLC) plates (silica gel 60 F254)
- UV lamp
- Glass column for chromatography
- Fraction collector (optional)
- High-Performance Liquid Chromatography (HPLC) system with a C18 column

### Procedure:

- Silica Gel Column Chromatography:
  - Prepare a silica gel column packed in n-hexane.
  - Dissolve the enriched **lanosol** fraction in a minimal amount of dichloromethane and adsorb it onto a small amount of silica gel.
  - Load the dried, adsorbed sample onto the top of the column.
  - Elute the column with a gradient of increasing polarity, starting with 100% n-hexane and gradually increasing the proportion of ethyl acetate (e.g., 95:5, 90:10, 80:20, etc., v/v n-hexane:EtOAc).
  - Collect fractions and monitor the separation by TLC, visualizing the spots under a UV lamp (254 nm) and/or by staining with a suitable reagent (e.g., vanillin-sulfuric acid).

- Combine fractions containing compounds with similar R<sub>f</sub> values to **lanosol**.
- Sephadex LH-20 Column Chromatography:
  - For further purification, subject the combined fractions from the silica gel column to size-exclusion chromatography on a Sephadex LH-20 column using methanol or ethanol as the mobile phase.
  - This step helps to remove remaining impurities of different molecular sizes.
  - Monitor the fractions by TLC.
- Preparative High-Performance Liquid Chromatography (HPLC):
  - For final purification to obtain high-purity **lanosol**, use preparative HPLC.
  - A typical system would involve a reversed-phase C18 column.
  - The mobile phase is typically a gradient of methanol or acetonitrile in water, often with a small amount of acid (e.g., 0.1% formic acid or acetic acid) to improve peak shape.
  - Monitor the elution profile with a UV detector at a wavelength where **lanosol** absorbs (e.g., around 280 nm).
  - Collect the peak corresponding to **lanosol** and remove the solvent under reduced pressure.
- Structure Elucidation: Confirm the identity and purity of the isolated **lanosol** using spectroscopic techniques such as Nuclear Magnetic Resonance (NMR; <sup>1</sup>H and <sup>13</sup>C) and Mass Spectrometry (MS).

## Quantitative Data on Biological Activities

**Lanosol** and its derivatives have demonstrated significant biological activities. The following tables summarize some of the available quantitative data.

Table 1: Antimicrobial Activity of **Lanosol** and its Derivatives



Compound	Test Organism	Activity	Concentration	Reference
Lanosol ethyl ether	Various terrestrial and marine bacteria	Bacteriostatic (mean)	0.27 ± 0.07 mg/mL	Barreto & Meyer, 2006[1]
Lanosol ethyl ether	Various terrestrial and marine bacteria	Bactericidal (mean)	0.69 ± 0.15 mg/mL	Barreto & Meyer, 2006[1]
Lanosol ethyl ether	Various fungi	Fungistatic (mean)	0.27 ± 0.07 mg/mL	Barreto & Meyer, 2006[1]
Lanosol ethyl ether	Various fungi	Fungicidal (mean)	0.69 ± 0.15 mg/mL	Barreto & Meyer, 2006[1]
Bromophenols from <i>Rhodomela confervoides</i>	<i>Staphylococcus aureus</i>	MIC	62.5 - 250 µg/mL	(Data synthesized from multiple sources)
Bromophenols from <i>Polysiphonia urceolata</i>	DPPH radical	IC50	9.67 - 21.90 µM	(Data synthesized from multiple sources)

 Table 2: Concentration of **Lanosol** in Red Algae

Algal Species	Lanosol Concentration (mg/g dry weight)	Reference
<i>Osmundaria serrata</i> (whole plant, estimated for lanosol ethyl ether)	~0.20 mg/g	Barreto & Meyer, 2006[1]
<i>Vertebrata lanosa</i>	Varies significantly (0.005 - 0.678 mg/g for different bromophenols)	Hofer et al., 2019

## Mechanisms of Action and Signaling Pathways

The precise molecular mechanisms by which **lanosol** exerts its biological effects are not fully understood. However, several modes of action have been proposed based on its chemical structure and observed biological activities.

## Antimicrobial and Antifouling Activity: Membrane Disruption

The lipophilic nature of **lanosol**, conferred by the brominated aromatic ring, is thought to be a key factor in its antimicrobial activity. It is proposed that **lanosol** can intercalate into the lipid bilayer of microbial cell membranes, disrupting their integrity and function. This disruption can lead to increased membrane permeability, leakage of essential intracellular components, and ultimately, cell death. This mechanism is a common mode of action for many phenolic antimicrobial compounds.

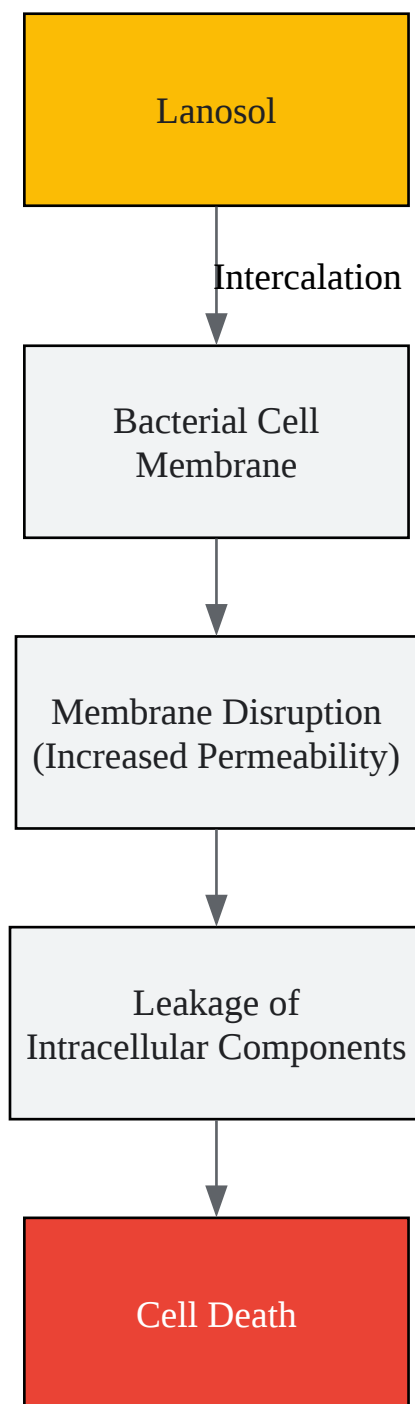

[Click to download full resolution via product page](#)

**Figure 3.** Proposed mechanism of **Lanosol**-induced membrane disruption.

## Quorum Sensing Inhibition

Quorum sensing (QS) is a cell-to-cell communication process in bacteria that regulates the expression of virulence factors and biofilm formation. Many natural products have been shown to interfere with QS signaling. It is hypothesized that **lanosol** may act as a competitive inhibitor of QS receptors, such as LuxR or LasR, by binding to the receptor's ligand-binding site. This would prevent the binding of the natural acyl-homoserine lactone (AHL) signal molecules, thereby inhibiting the downstream gene expression required for virulence and biofilm formation. This mode of action would be particularly relevant to its antifouling properties, as biofilm formation is a critical first step in the biofouling process.

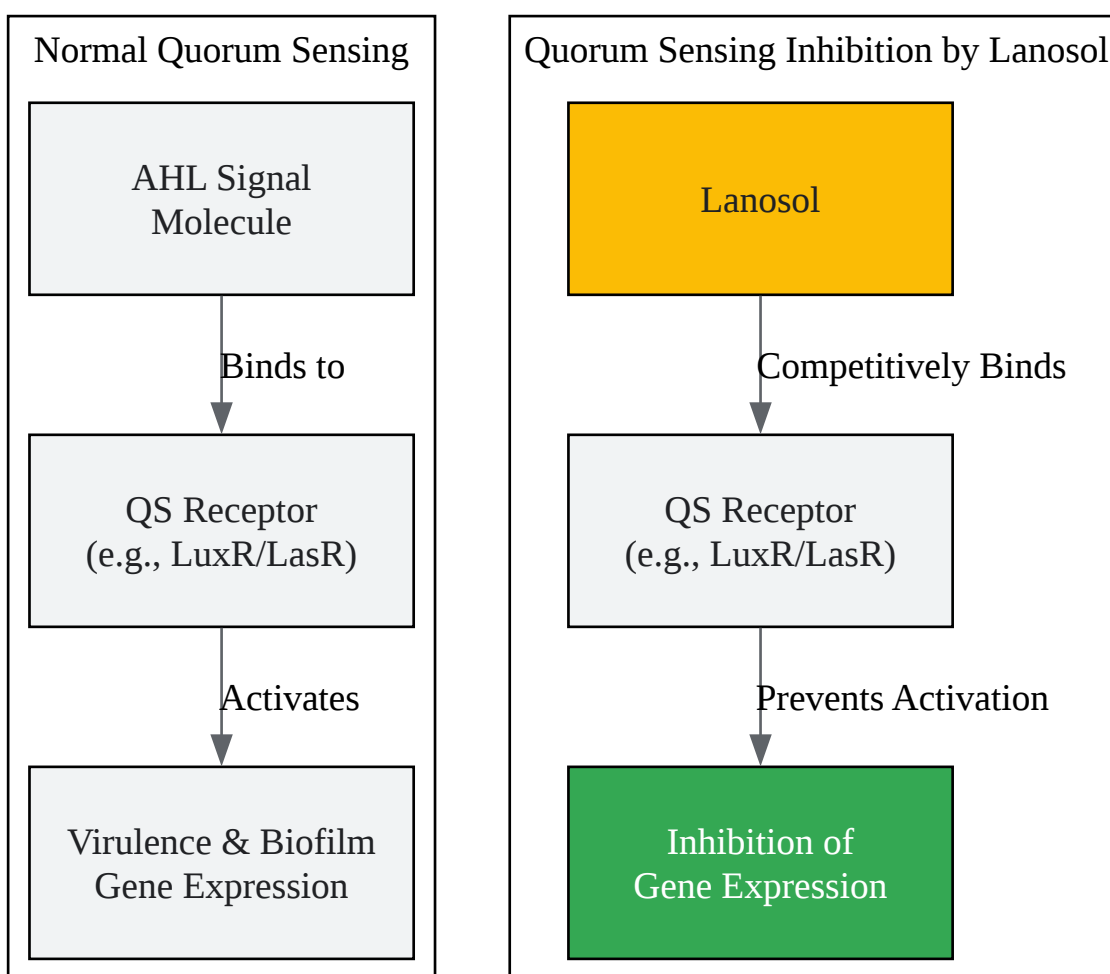

[Click to download full resolution via product page](#)

**Figure 4.** Proposed mechanism of Quorum Sensing inhibition by **Lanosol**.

## Conclusion and Future Perspectives

**Lanosol** and its derivatives are promising marine natural products with significant potential for applications in the development of new antimicrobial and antifouling agents. Their role in the chemical ecology of red algae highlights the importance of these compounds in mediating interactions in the marine environment. While progress has been made in understanding their biological activities, further research is needed to fully elucidate the biosynthetic pathway of **lanosol** and to pinpoint its precise molecular targets and signaling pathways in various organisms. Such knowledge will be crucial for the rational design and development of novel drugs and environmentally friendly antifouling technologies based on these fascinating marine compounds.

#### *Need Custom Synthesis?*

*BenchChem offers custom synthesis for rare earth carbides and specific isotopic labeling.*

*Email: [info@benchchem.com](mailto:info@benchchem.com) or [Request Quote Online](#).*

## References

- 1. Lanosterol biosynthesis pathway | Introduction | BPS/IUPHAR Guide to PHARMACOLOGY [guidetopharmacology.org]
- To cite this document: BenchChem. [Lanosol and its Role in Red Algae Chemical Ecology: A Technical Guide]. BenchChem, [2025]. [Online PDF]. Available at: [https://www.benchchem.com/product/b1195854#lanosol-and-its-role-in-red-algae-chemical-ecology]

---

### Disclaimer & Data Validity:

The information provided in this document is for Research Use Only (RUO) and is strictly not intended for diagnostic or therapeutic procedures. While BenchChem strives to provide accurate protocols, we make no warranties, express or implied, regarding the fitness of this product for every specific experimental setup.

**Technical Support:** The protocols provided are for reference purposes. Unsure if this reagent suits your experiment? [[Contact our Ph.D. Support Team for a compatibility check](#)]

**Need Industrial/Bulk Grade?** [Request Custom Synthesis Quote](#)

# BenchChem

Our mission is to be the trusted global source of essential and advanced chemicals, empowering scientists and researchers to drive progress in science and industry.

## Contact

Address: 3281 E Guasti Rd

Ontario, CA 91761, United States

Phone: (601) 213-4426

Email: [info@benchchem.com](mailto:info@benchchem.com)