

# Kuromanin Chloride: A Technical Guide for Researchers

**Author:** BenchChem Technical Support Team. **Date:** December 2025

## Compound of Interest

Compound Name: *Kuromanin chloride*

Cat. No.: *B1668917*

[Get Quote](#)

For Researchers, Scientists, and Drug Development Professionals

## Abstract

**Kuromanin chloride**, also known as Chrysanthemins or Cyanidin-3-O-glucoside chloride, is a prominent member of the anthocyanin family of flavonoids. Widely found in various pigmented fruits and vegetables, this natural compound has garnered significant scientific interest due to its potent antioxidant, neuroprotective, anti-inflammatory, and anti-cancer properties. This technical guide provides a comprehensive overview of **Kuromanin chloride**, including its physicochemical properties, and delves into its mechanisms of action. Detailed experimental protocols for assessing its biological activities and illustrative diagrams of key signaling pathways are presented to facilitate further research and drug development endeavors.

## Physicochemical Properties

**Kuromanin chloride** is a water-soluble glycoside of cyanidin. Its fundamental properties are essential for experimental design and interpretation.

Property	Value	Reference
CAS Number	7084-24-4	[1][2][3][4]
Molecular Weight	484.84 g/mol	[1][2][3][4]
Molecular Formula	C <sub>21</sub> H <sub>21</sub> ClO <sub>11</sub>	[1][2]
Appearance	Brown to reddish-brown solid	[1]
Synonyms	Chrysanthemin, Cyanidin 3-O-glucoside chloride, Asterin	[2][3]

## Biological Activities and Mechanisms of Action

**Kuromanin chloride** exhibits a diverse range of biological activities, making it a promising candidate for therapeutic development. Its primary mechanism is often attributed to its potent antioxidant capacity, which underpins its efficacy in various disease models.

### Neuroprotective Effects

**Kuromanin chloride** has demonstrated significant neuroprotective properties, particularly against oxidative stress-induced neuronal damage. It has been shown to protect neuronal cells from excitotoxicity and reduce the production of reactive oxygen species (ROS).

### Anti-Cancer Activity

Emerging evidence suggests that **Kuromanin chloride** possesses anti-proliferative and pro-apoptotic effects in various cancer cell lines. Its mechanisms of action include the induction of apoptosis through caspase activation and the modulation of key signaling pathways involved in cancer progression.

### CD38 Inhibition

**Kuromanin chloride** is a known inhibitor of the ectoenzyme CD38.[1] CD38 is involved in calcium signaling and NAD<sup>+</sup> metabolism, and its dysregulation has been implicated in various diseases, including cancer and metabolic disorders. By inhibiting CD38, **Kuromanin chloride** can modulate intracellular NAD<sup>+</sup> levels and downstream signaling pathways.

## Key Signaling Pathways

The biological effects of **Kuromanin chloride** are mediated through its interaction with several critical intracellular signaling pathways.

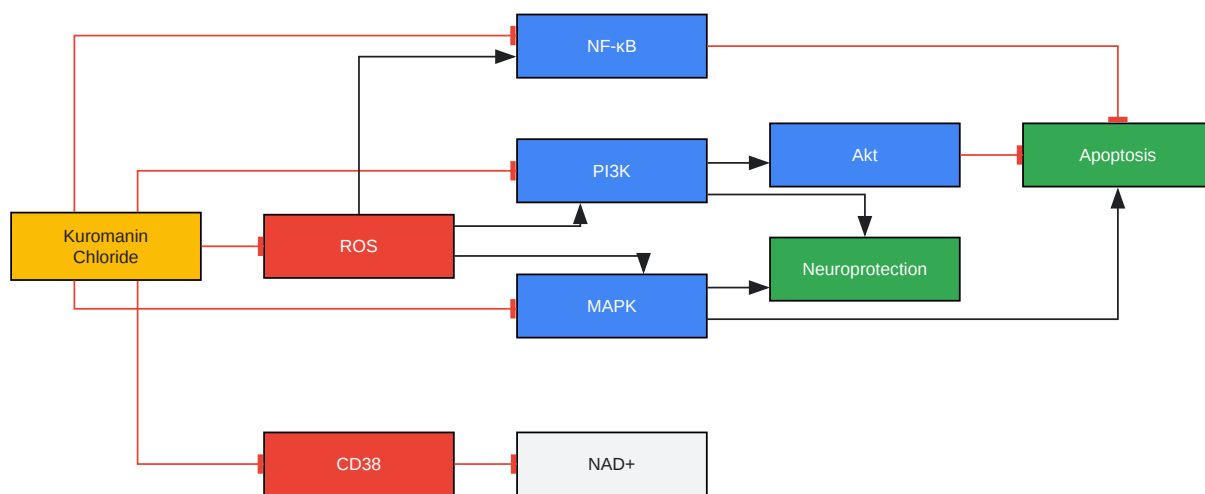

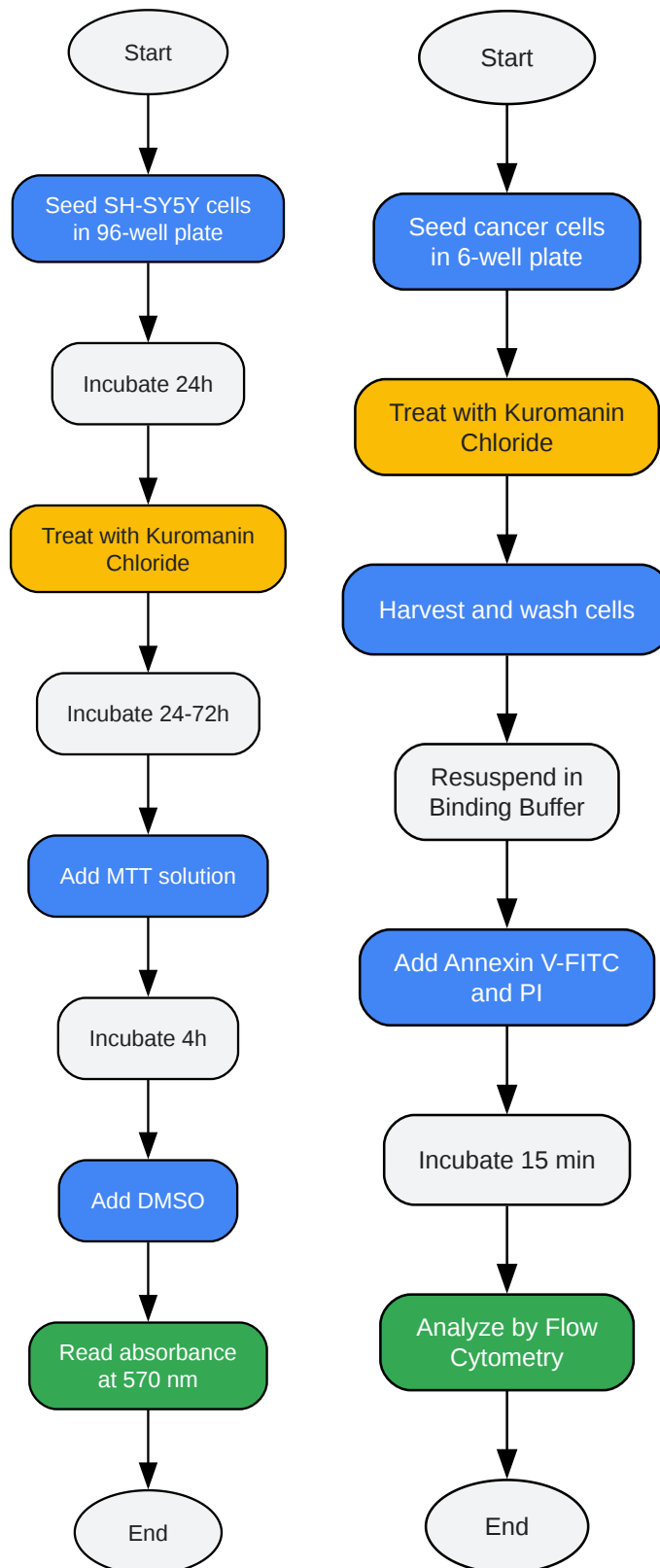

[Click to download full resolution via product page](#)

### Need Custom Synthesis?

BenchChem offers custom synthesis for rare earth carbides and specific isotopic labeling.

Email: [info@benchchem.com](mailto:info@benchchem.com) or [Request Quote Online](#).

## References

- 1. researchgate.net [researchgate.net]
- 2. rsc.org [rsc.org]
- 3. rsc.org [rsc.org]
- 4. Frontiers | Neuroprotective Effects of Kuromanin Chloride (Anthocyanin) Against Glutamatergic Excitotoxicity in Neuroblastoma Cells [frontiersin.org]
- To cite this document: BenchChem. [Kuromanin Chloride: A Technical Guide for Researchers]. BenchChem, [2025]. [Online PDF]. Available at: [https://www.benchchem.com/product/b1668917#kuromanin-chloride-cas-number-and-molecular-weight]

---

### Disclaimer & Data Validity:

The information provided in this document is for Research Use Only (RUO) and is strictly not intended for diagnostic or therapeutic procedures. While BenchChem strives to provide accurate protocols, we make no warranties, express or implied, regarding the fitness of this product for every specific experimental setup.

**Technical Support:** The protocols provided are for reference purposes. Unsure if this reagent suits your experiment? [[Contact our Ph.D. Support Team for a compatibility check](#)]

**Need Industrial/Bulk Grade?** [Request Custom Synthesis Quote](#)

# BenchChem

Our mission is to be the trusted global source of essential and advanced chemicals, empowering scientists and researchers to drive progress in science and industry.

## Contact

Address: 3281 E Guasti Rd

Ontario, CA 91761, United States

Phone: (601) 213-4426

Email: [info@benchchem.com](mailto:info@benchchem.com)