

JP83: A Technical Overview of a High-Powered Audio Amplifier

Author: BenchChem Technical Support Team. **Date:** December 2025

Compound of Interest

Compound Name: JP83

Cat. No.: B560362

[Get Quote](#)

Initial investigations into the mechanism of action of "**JP83**" have revealed that this identifier does not correspond to a pharmacological agent or a compound with a biological mode of action. Instead, **JP83** is the model name for a high-power, class D monoblock audio amplifier manufactured by Down4Sound. Consequently, the requested in-depth technical guide on its core mechanism of action, experimental protocols, and signaling pathways in a biological context cannot be provided.

This document serves to present the technical specifications and operational parameters of the Down4Sound **JP83** amplifier, catering to an audience with an interest in audio engineering and electronics.

Technical Specifications

The Down4Sound **JP83** is an 8300-watt RMS monoblock amplifier designed for high-power car audio subwoofer applications.[1][2] Its primary function is to amplify a low-level audio signal to a level sufficient to drive large speakers (subwoofers). The core of its operation lies in its Class D amplifier topology, which allows for high efficiency and significant power output in a relatively compact design.[1]

A summary of the key quantitative data for the **JP83** amplifier is presented in the table below:

Parameter	Value
Power Ratings (RMS)	
@ 1 ohm	8300 Watts[1][2][3][4]
@ 2 ohms	6300 Watts[1][2][3][4]
@ 4 ohms	3300 Watts[1][2][3][4]
General Specifications	
Frequency Response	14Hz – 271Hz[2][3][4]
Signal to Noise Ratio	92dB[2][3][4]
Damping Factor	>500[2][3][4]
Input Sensitivity	6V – 0.2V[2][3][4]
Working Voltage	9V – 16V[2][5]
Fusing	900A Total (3 x 300A)[2][3]
Filters	
Subsonic Filter	10Hz – 50Hz[2][3][4]
Low Pass Filter	35Hz – 250Hz[2][3][4]
Physical Dimensions	
Length	24 inches[1][3]
Width	9.37 inches[3]
Height	2.63 inches[3]

Operational Mechanism and Features

The fundamental "mechanism of action" of the **JP83** amplifier involves taking a low-voltage audio input signal and using it to modulate a high-voltage power supply, thereby creating a high-power replica of the input signal at the speaker outputs. This is achieved through high-frequency switching and pulse-width modulation, characteristic of Class D amplifiers.

Key operational features include:

- **Power Inputs:** The amplifier is equipped with three 0-gauge power and ground inputs to accommodate the high current draw required for its operation.[3]
- **Speaker Outputs:** It features 4-gauge speaker outputs.[2][3][4]
- **Cooling:** To manage the heat generated during high-power operation, the **JP83** incorporates a larger heat sink and active high-flow internal fans.[3][4]
- **Strappable Connection:** Two **JP83** amplifiers can be linked together to drive a single load, effectively doubling the power output. In this configuration, one amplifier is designated as the "master" and the other as the "slave," with the master unit controlling the settings for both.[5]
- **Bluetooth Remote Control:** The amplifier includes a Bluetooth remote control that can display voltage and temperature, and also features a clipping indicator.[2][3]
- **Protection Circuitry:** The amplifier is equipped with protection circuits to prevent damage from conditions such as overheating and speaker impedance falling below the minimum stable load (1 ohm for a single unit, 2 ohms when strapped).[5]

Experimental Protocols

In the context of audio electronics, "experimental protocols" refer to the testing procedures used to verify the amplifier's performance specifications. A common procedure is "amp dyno" testing.

Amplifier Dynamometer (Dyno) Testing Workflow:

This test measures the actual power output of the amplifier under various load conditions.

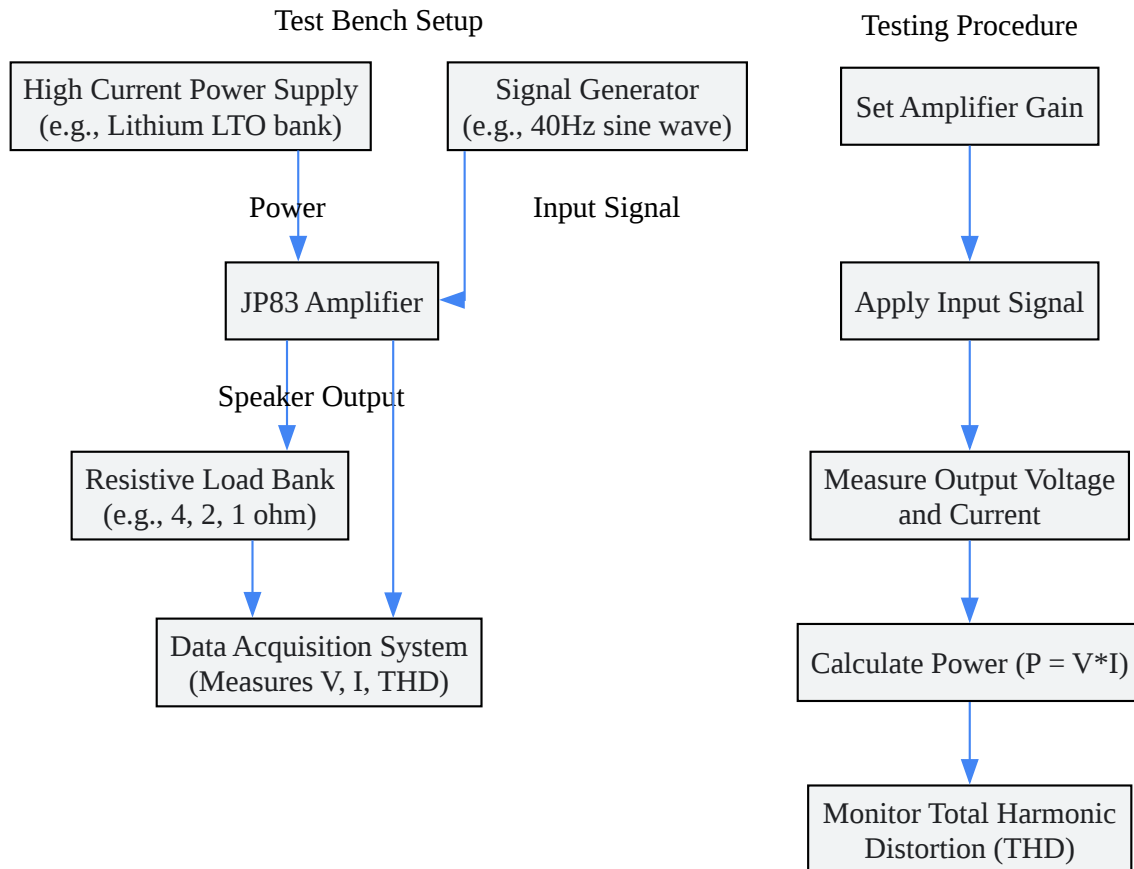

[Click to download full resolution via product page](#)

Amplifier Dynamometer Testing Workflow

- **Setup:** The amplifier is connected to a high-current DC power supply and a resistive load bank set to a specific impedance (e.g., 4, 2, or 1 ohm). A signal generator provides a test tone (e.g., a 40Hz sine wave), and a data acquisition system is connected to measure voltage, current, and distortion.
- **Procedure:** The amplifier's gain is set. The input signal is applied, and the output voltage and current are measured just before the output signal begins to distort or "clip."

- Data Analysis: The power output is calculated from the measured voltage and current. The Total Harmonic Distortion (THD) is monitored to ensure the output signal is clean.[5]

Signaling Pathway

The "signaling pathway" for the **JP83** amplifier is the path the audio signal takes from the input to the output.

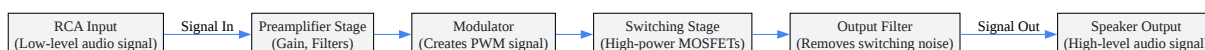

[Click to download full resolution via product page](#)

JP83 Audio Signal Flow

- RCA Input: The audio signal originates from a source unit (head unit) and enters the amplifier via RCA connectors.[1]
- Preamplifier Stage: The signal first goes to the preamp section, where the gain, low-pass filter, and subsonic filter are applied according to the user's settings.[1]
- Modulator: The processed analog signal is then converted into a high-frequency pulse-width modulated (PWM) signal.
- Switching Stage: This PWM signal rapidly switches the amplifier's high-power transistors (MOSFETs) on and off.
- Output Filter: The high-power, high-frequency signal passes through a low-pass filter to remove the switching noise, leaving a high-power replica of the original audio signal.
- Speaker Output: This high-power signal is then sent to the subwoofers.[5]

Need Custom Synthesis?

BenchChem offers custom synthesis for rare earth carbides and specific isotopic labeling.

Email: info@benchchem.com or [Request Quote Online](#).

References

- 1. youtube.com [youtube.com]
- 2. down4sound-jp83-8300-watt-rms-class-d-amplifier - Car Audio Direct [caraudiorect.ca]
- 3. down4soundshop.com [down4soundshop.com]
- 4. ampedupcaraudio.com [ampedupcaraudio.com]
- 5. manuals.plus [manuals.plus]
- To cite this document: BenchChem. [JP83: A Technical Overview of a High-Powered Audio Amplifier]. BenchChem, [2025]. [Online PDF]. Available at: [https://www.benchchem.com/product/b560362#what-is-the-mechanism-of-action-of-jp83]

Disclaimer & Data Validity:

The information provided in this document is for Research Use Only (RUO) and is strictly not intended for diagnostic or therapeutic procedures. While BenchChem strives to provide accurate protocols, we make no warranties, express or implied, regarding the fitness of this product for every specific experimental setup.

Technical Support: The protocols provided are for reference purposes. Unsure if this reagent suits your experiment? [[Contact our Ph.D. Support Team for a compatibility check](#)]

Need Industrial/Bulk Grade? [Request Custom Synthesis Quote](#)

BenchChem

Our mission is to be the trusted global source of essential and advanced chemicals, empowering scientists and researchers to drive progress in science and industry.

Contact

Address: 3281 E Guasti Rd
Ontario, CA 91761, United States
Phone: (601) 213-4426
Email: info@benchchem.com